



Department of
Primary Industries and
Regional Development

*We're working for
Western Australia.*

Fisheries Research Report No. 332

Ecological Risk Assessment for the Western Australian Offshore Crustacean Resource.

J. How, K.A. Smith, H. Donnelly, L. Wiberg and R. Oliver

March 2023

Correct citation:

How J., Smith K.A., Donnelly H., Wiberg L. and Oliver R. (2023). Ecological Risk Assessment for the Western Australian Offshore Crustacean Resource. Fisheries Research Report No. 332. Department of Primary Industries and Regional Development, Western Australia. 104 pp.

Enquiries:

WA Fisheries and Marine Research Laboratories,
PO Box 20,
North Beach, WA 6920

Tel: +61 8 9203 0111

Email: library@fish.wa.gov.au

Website: fish.wa.gov.au

A complete list of Fisheries Research Reports is available online at **fish.wa.gov.au**

Important disclaimer

The Chief Executive Officer of the Department of Primary Industries and Regional Development and the State of Western Australia accept no liability whatsoever by reason of negligence or otherwise arising from the use or release of this information or any part of it.

Department of Primary Industries and Regional Development
Gordon Stephenson House
140 William Street
PERTH WA 6000
Telephone: (08) 6551 4444
Website: dpird.wa.gov.au
ABN: 18 951 343 745

ISSN: 2202-5758 (Online) ISBN: 978-1-925415-00-1 (Online)

Copyright © State of Western Australia (Department of Primary Industries and Regional Development) 2023

Table of Contents

List of Acronyms	v
Executive Summary	6
1.0 Introduction	7
2.0 Offshore Crustacean Resource	7
3.0 Aquatic Environment	8
3.1 Gascoyne Coast Bioregion	8
3.2 West Coast Bioregion.....	10
3.3 South Coast Bioregion.....	10
4.0 Fisheries/Sectors Accessing the Resource	11
4.1 West Coast Deep Sea Crustacean Managed Fishery (WCDSCMF)	12
4.2 South Coast Crustacean Managed Fishery (SCCMF)	22
4.3 West Coast Rock Lobster Managed Fishery (WCRLMF).....	27
4.4 Recreational Fishery	33
4.5 Customary fishing.....	33
4.6 Compliance	34
5.0 Ecological Impacts	35
5.1 Retained Species	35
5.2 Bycatch species	47
5.3 Endangered, Threatened and Protected (ETP) Species	52
5.4 Habitats	57
5.5 Ecosystem Structure	60
5.6 Broader Environment.....	64
6.0 External Factors	66
7.0 Risk Assessment Methodology	66
7.1 Scope	67
7.2 Risk Identification	67
7.3 Previous Risk Assessments for the Resource.	68
7.4 Risk Assessment Process	68
8.0 Risk Analysis	69
8.1 Retained species.....	74
8.2 Bycatch (discarded) species.....	78
8.3 ETP species	79
8.4 Habitats	84

8.5 Ecosystem structure	87
8.6 Broader environment	90
9.0 References.....	91
Appendix 1: Consequence – Likelihood Risk Matrix and Description of Risk Levels	99
Appendix 2: Definitions of Consequence and Likelihood Levels.....	100
Appendix 3: ERA workshop stakeholders	102

List of Acronyms

ASL	Australian sea lion
BC Act	<i>Biodiversity Conservation Act 2016</i>
CDR	Catch Disposal Record
CI	Confidence Intervals
CITES	Convention on International Trade in Endangered Species of Wild Fauna and Flora
CL	Carapace Length
CW	Carapace Width
DPIRD	Department of Primary Industries and Regional Development
EBFM	Ecosystem Based Fisheries Management
EEZ	Exclusive Economic Zone
ENSO	El Niño Southern Oscillation
EPBC Act	<i>Environment Protection and Biodiversity Conservation Act 1999</i>
ERA	Ecological Risk Assessment
ERLMF	Esperance Rock Lobster Managed Fishery
ETP	Endangered, Threatened and Protected Species
FRDC	Fisheries Research and Development Corporation
FRMR	<i>Fish Resources Management Regulations 1995</i>
GCB	Gascoyne Coast Bioregion
IMCRA	Integrated Marine and Coastal Regionalisation of Australia
ITQ	Individual Transferable Quota
IUCN	International Union for Conservation of Nature
MARPOL	International Convention for the Prevention of Pollution from Ships
MSC	Marine Stewardship Council
MSY	Maximum Sustainable Yield
LNFS	Long-nosed fur seals
OCP	Operational Compliance Plans
NCB	North Coast Bioregion
NSW	New South Wales
SA	South Australia
SARLF	South Australian Rock Lobster Fishery
SCCMF	South Coast Crustacean Managed Fishery
SLED	Sea Lion Exclusion Device
SCB	South Coast Bioregion
TAC	Total Allowable Catch
TACC	Total Allowable Commercial Catch
TDGDLF	Temperate Demersal Gillnet and Demersal Longline Fishery
WA	Western Australia
WCB	West Coast Bioregion
WCDSCMF	West Coast Deep Sea Crustacean Managed Fishery
WCRLMF	West Coast Rock Lobster Managed Fishery
WHARLMF	Windy Harbour-Augusta Managed Fishery
WRL	Western Rock Lobster
WTO	Wildlife Trade Operation

Executive Summary

In December 2022, the Department of Primary Industries and Regional Development (DPIRD) convened an ecological risk assessment (ERA) of the fisheries that access the Offshore Crustacean Resource (Resource).

The Western Australian commercial fisheries that access the Resource are the West Coast Deep Sea Crustacean Managed Fishery, South Coast Crustacean Managed Fishery and West Coast Rock Lobster Managed Fishery. Due to the predominantly offshore distribution of the Resource, there is only minor recreational and customary access of this Resource related to harvesting of southern rock lobster on the south coast.

The ERA considered the potential ecological impacts of harvesting the Resource. The assessment focused on evaluating the impact of the commercial fishing sector on all relevant retained and bycatch species, endangered, threatened and protected (ETP) species, habitats and the broader environment.

A broad range of stakeholders were invited to participate in the ERA workshop, including representatives of the commercial, recreational, customary and aquaculture fishing sectors, State and Commonwealth Government agencies, the conservation sector, universities and DPIRD staff including fisheries management, research, compliance and biosecurity personnel.

Risk scores were determined based on available scientific information and expert knowledge. The assessment conforms to the AS/NZS ISO 31000 risk management standard, and to the methodology adopted by DPIRD which uses a consequence-likelihood analysis for estimating risk.

Forty three ecological components were scored for risk. The majority (34) of components were evaluated as low or negligible risks, which do not require any specific control measures. Four components were evaluated as medium risks, which were assessed as acceptable under the current monitoring and control measures already in place.

There were four high risks and one severe risk, which all related to stocks of the primary target species. These stocks had been formally assessed by DPIRD prior to this ERA and the pre-existing risk scores from those assessments were adopted in this ERA. Management changes have already been implemented that are expected to reduce the risk for each stock to an acceptable level.

It is recommended that all risks be reviewed in five years.

1.0 Introduction

The Department of Primary Industries and Regional Development (DPIRD, Department) in Western Australia (WA) uses an Ecosystem-Based Fisheries Management (EBFM) approach that considers all relevant ecological, social, economic and governance issues to deliver community outcomes (Fletcher *et al.* 2010; 2012). Ecological risk assessments (ERAs) are part of this framework and are undertaken periodically to assess the impacts of fisheries on all the different components of the aquatic environments in which they operate. Outcomes of ERAs are used to

- inform EBFM-based harvest strategies;
- prioritise the Department's monitoring, research and management activities (Fletcher 2015; Fletcher *et al.* 2016); and
- inform external processes such as Marine Stewardship Council (MSC) certifications and Wildlife Trade Operation (WTO) approvals.

This report provides a description of the Offshore Crustacean Resource (Resource) and all the fishing activities that interact with the Resource. The Resource includes southern rock lobster (*Jasus edwardsii*), crystal crab (*Chaceon albus*), champagne crab (*Hypothalassia acerba*) and giant crab (*Pseudocarcinus gigas*).

The Resource is harvested by three commercial fisheries: West Coast Deep Sea Crustacean Managed Fishery (WCDSCMF), South Coast Crustacean Managed Fishery (SCCMF) and West Coast Rock Lobster Managed Fishery (WCRLMF). Due to its offshore nature, there is limited recreational or customary access to the Resource, with catch by these sectors restricted to southern rock lobster.

The ERA will consider the potential ecological impacts of these fisheries on all relevant retained and bycatch species, Endangered, Threatened and Protected (ETP) species, habitats, and the broader ecosystem.

The risk assessment methodology uses a consequence-likelihood analysis, which involves examining the magnitude of potential consequences from fishing activities and the likelihood that those consequences will occur given current management controls.

The scope of this ERA is for the next five years (through to 2027). It is envisioned that ERAs will be undertaken periodically (approximately every five years) to reassess any current or new issues that may arise. However, a risk assessment can also be triggered if there are significant changes identified in fishery operations or management activities that may change current risk levels.

2.0 Offshore Crustacean Resource

The Offshore Crustacean Resource comprises all crustaceans (except Western Rock Lobster) which are of commercial value and found on the continental shelf or slope from the South Australian / WA border eastwards and then northwards to the WA / Northern Territory border.

Currently, there are four main species which comprise the Offshore Crustacean Resource, southern rock lobster (*Jasus edwardsii*), crystal crab (*Chaceon albus*), champagne crab (*Hypothalassia acerba*) and giant crab (*Pseudocarcinus gigas*).

Western Rock Lobster (*Panulirus cygnus*) is managed separately. An ERA for the Western Rock Lobster Resource was conducted in April 2022 (Stoklosa 2022).

3.0 Aquatic Environment

The Offshore Crustacean Resource encompasses the coastal, continental shelf and slope aquatic environments out to the Australian Exclusive Economic Zone (EEZ; 200 nm boundary) spanning all marine waters of the state, from the WA / Northern Territory border to the WA / South Australian border (Figure 3-1). Given this extensive distribution, the aquatic environment of the Resource ranges from tropical habitats (including sand/mudflats, filter feeder communities, coral reef and soft-bottom areas) in the North Coast Bioregion (NCB) through the transitional temperate and tropical waters of the Gascoyne Coast Bioregion (GCB) and West Coast Bioregion (WCB) to the temperate waters of the South Coast Bioregion (SCB). There has, however, been no harvesting of the Resource in the North Coast Bioregion to date.

3.1 Gascoyne Coast Bioregion

The GCB extends northwards from Kalbarri (27.70°S, 114.16°E) to the Exmouth Gulf (114.50°E) (Figure 3-1). The GCB is a transition zone from the warm, tropical waters of northern WA and the cooler, more temperate waters of the southwest. Offshore ocean temperatures range from about 22°C to 28°C, while the inner areas of Shark Bay regularly fall to 15°C in winter. Limited annual rainfall occurs in winter and summer because of the influence of tropical cyclones, the incursion of warm, moist air from the Kimberley region and mid-latitude depressions. Tropical cyclones with wind speeds more than 40-50 knots occur in the north around Exmouth Gulf every three to five years, with less intensive systems occurring annually from January to March.

The GCB coastline is characterised by high cliffs in the southern half, changing to fringing coral reefs in the north. Coastal waters generally experience high wave energy due to the strong trade wind system. Exmouth Gulf is seasonally influenced by extreme tropical summer cyclones, while Shark Bay receives infrequent cyclones, but is affected at times by river outflows from inland cyclone-based summer rainfall.

The waters off the Gascoyne Coast are also strongly influenced by the southward-flowing Leeuwin Current that is generated by ocean flows from the Pacific passing through the Indonesian Archipelago. This tropical current becomes evident in the North West Cape area and flows along the edge of the narrow continental shelf where, coupled with low rainfall and run-off plus the north flowing Ningaloo Current, it supports the diverse Ningaloo Reef marine ecosystem.

The outer area of the large marine embayment of the World Heritage-listed Shark Bay is also influenced by the warm winter current. The inner waters of the embayment are hyper-saline, due to the high evaporation and low rainfall of the adjacent terrestrial desert areas. The sea floor of Shark Bay and the continental shelf are typically sandy compared to Exmouth Gulf, which has more mud areas and greater turbidity. Ningaloo Reef in the north of the Bioregion is the largest continuous reef in WA and is one of the most significant fringing reefs in Australia. The Bioregion has areas of mangroves, mostly in Exmouth Gulf, and seagrass beds are located in a number of areas, including extensive beds in Shark Bay.

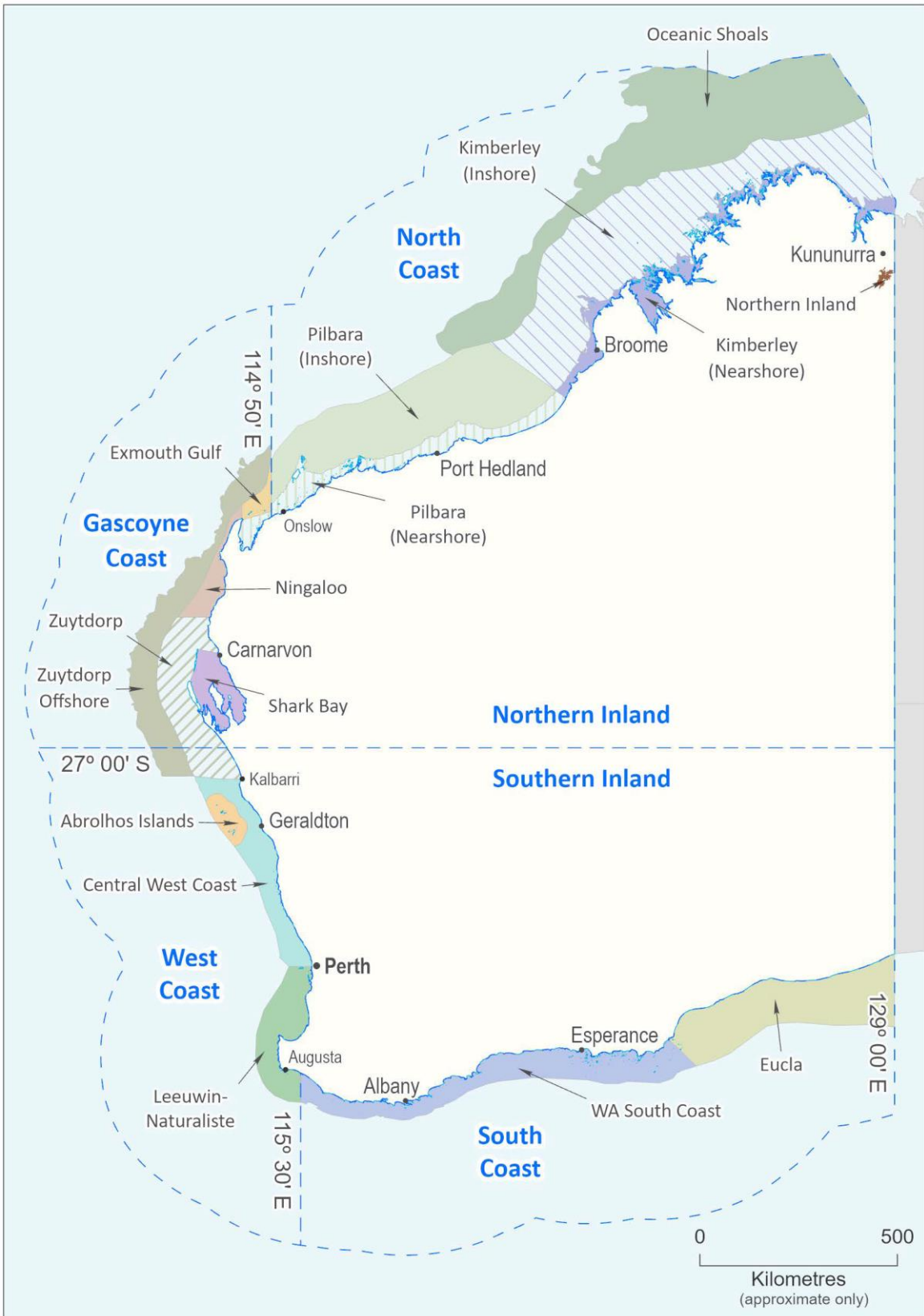

Figure 3-1 DPIRD Bioregions in WA (blue labels) and Integrated Marine and Coastal Regionalisation of Australia (IMCRA) ecosystems. The Offshore Crustacean Resource encompasses all four marine Bioregions.

3.2 West Coast Bioregion

The WCB extends from just north of Kalbarri (27.70°S, 114.16°E) to Augusta (34.31°S, 115.16°E) (Figure 3-1). It is predominantly a temperate oceanic zone, but it is heavily influenced by the Leeuwin Current which transports warm tropical water, and some tropical species, southward along the edge of the continental shelf. Most fish species in the WCB are temperate, in keeping with the coastal water temperatures that range from 18°C to about 24°C. The Leeuwin Current also supports the hard coral reef system at the Houtman Abrolhos Islands (latitude 29°S) and the extended southward distribution of many tropical species along the WCB and even into the SCB.

The Leeuwin Current, which can be up to several hundred kilometres wide along the WCB, flows most strongly in autumn/winter (April to August). The current is variable in strength from year-to-year, flowing at speeds typically around 1 knot, but has been recorded at 3 knots on occasions. The annual variability in current strength is reflected in variations in Fremantle sea level and is related to El Niño Southern Oscillation (ENSO) events in the Pacific Ocean. Weaker counter-currents, such as the cooler Capes Current that flows northward from Cape Leeuwin to as far as Shark Bay, flow along the inner shelf (shoreward of the Leeuwin Current) during summer and influence the distribution of many of the coastal finfish species.

The warm, low-nutrient water of the Leeuwin Current influences the growth and distribution of the temperate seagrasses that form extensive meadows in protected coastal waters of the WCB, generally in depths of <20 m (but up to 30 m), and act as major nursery areas for many fish species.

The WCB is characterised by exposed sandy beaches and a limestone reef system that creates surface reef lines, often about 5 km off the coast. Further offshore, the continental shelf habitats are typically composed of coarse sand interspersed with low limestone reef associated with old shorelines. There are few areas of protected water along the WCB, the exceptions being within the Abrolhos Islands, the leeward sides of some small islands off the Midwest Coast, plus behind Rottnest and Garden Islands in the Perth metropolitan area.

The two significant marine embayments in the WCB are Cockburn Sound and Geographe Bay. In the WCB, there are four significant estuarine systems – the Swan-Canning, Peel-Harvey and Leschenault estuaries and Hardy Inlet (Blackwood estuary). All of these are permanently open to the sea and form an extension of the marine environment except when freshwater run-off displaces the oceanic water for a short period in winter and spring. Southward of Cape Naturaliste, the coastline changes from limestone to predominantly granite and becomes more exposed to the influences of the Southern Ocean.

3.3 South Coast Bioregion

The SCB extends east from Augusta (34.310°S, 115.16°E) to the South Australian (SA) border (Figure 3-1). The continental shelf waters of the SCB are generally temperate but low in nutrients, due to the seasonal winter presence of the tail of the tropical Leeuwin Current and limited terrestrial run-off from an infertile landscape. Sea surface temperatures typically range from approximately 15°C to 21°C, which is warmer than would normally be expected in these latitudes due to the influence of the Leeuwin Current. The effect of the Leeuwin Current, particularly west of Albany, limits winter minimum temperatures (away from terrestrial effects along the beaches) to about 16°C to 17°C. Fish stocks in this region are predominantly temperate, with many species' distributions extending right across southern Australia. Tropical species are occasionally found, mostly brought into the area as larvae by the Leeuwin Current.

The SCB is a high-energy environment, heavily influenced by large swells generated in the Southern Ocean. The coastline from Cape Leeuwin to Israelite Bay is characterised by white sand beaches separated by high granite headlands. East of Israelite Bay, there are long sandy beaches backed by large sand dunes, until replaced by high limestone cliffs at the SA border. There are few large areas of protected water in the SCB, the exceptions being around Albany and in the Recherche Archipelago off Esperance.

The western section of the coastline receives significant winter rainfall and hosts numerous estuaries fed by winter-flowing rivers. Several of these, such as Walpole/Nornalup Inlet and Oyster Harbour, are permanently open, but most are closed by sandbars and open only seasonally after heavy winter rains. The number of rivers and estuaries decreases to the east as the coastline becomes more arid. While these estuaries are influenced by terrestrial run-off and have relatively high nutrient levels (and some, such as Oyster Harbour and Wilson Inlet, are suffering eutrophication), their outflow to the ocean does not significantly influence the low nutrient status of coastal waters.

The marine habitats of the SCB are similar to the coastline, having fine, clear sand sea floors interspersed with occasional granite outcrops and limestone shoreline platforms and sub-surface reefs. A mixture of seagrass and kelp habitats occurs along the coast, with seagrass more abundant in protected waters and some of the more marine estuaries. The kelp habitats are diverse but dominated by the relatively small *Ecklonia radiata*, rather than the larger kelps expected in these latitudes where waters are typically colder and have higher nutrient levels.

4.0 Fisheries/Sectors Accessing the Resource

The Offshore Crustacean Resource is targeted by the commercial West Coast Deep Sea Crustacean Managed Fishery (WCDSCMF) and South Coast Crustacean Managed Fishery. The Resource is also accessed by the commercial West Coast Rock Lobster Managed Fishery (WCRLMF), which retains champagne crabs as a by-product of fishing for western rock lobster (Table 4-1). Up to 12 deep sea crabs per day per boat are allowed to be retained by WCRLMF fishers. The southern rock lobster component of the Resource is also accessed by recreational sector and possibly by the customary sector.

Table 4-1 Catch (kg) of the Offshore Crustacean Resource by species and commercial fishery for the 2021 season.

Species	WCDSCMF	SCCMF	WCRLMF	TOTAL
Crystal Crab	139,939	2,736	0	142,675
Champagne Crab	14,008	2,818	1,509	18,335
Giant Crab	10	4,559	0	4,569
Southern Rock Lobster		6,207	21	6,228
TOTAL	153,957	16,320	1,530	171,807

4.1 West Coast Deep Sea Crustacean Managed Fishery (WCDSCMF)

4.1.1 History of Development

Commercial interest in the Resource on the west coast was first expressed during the 1960-1980s, mainly for champagne and giant crabs. While initial catches were focused on champagne crabs, the discovery of crystal crab saw the fishery change its targeting to focus almost solely on crystal crabs since the early 2000s (Figure 4-1).

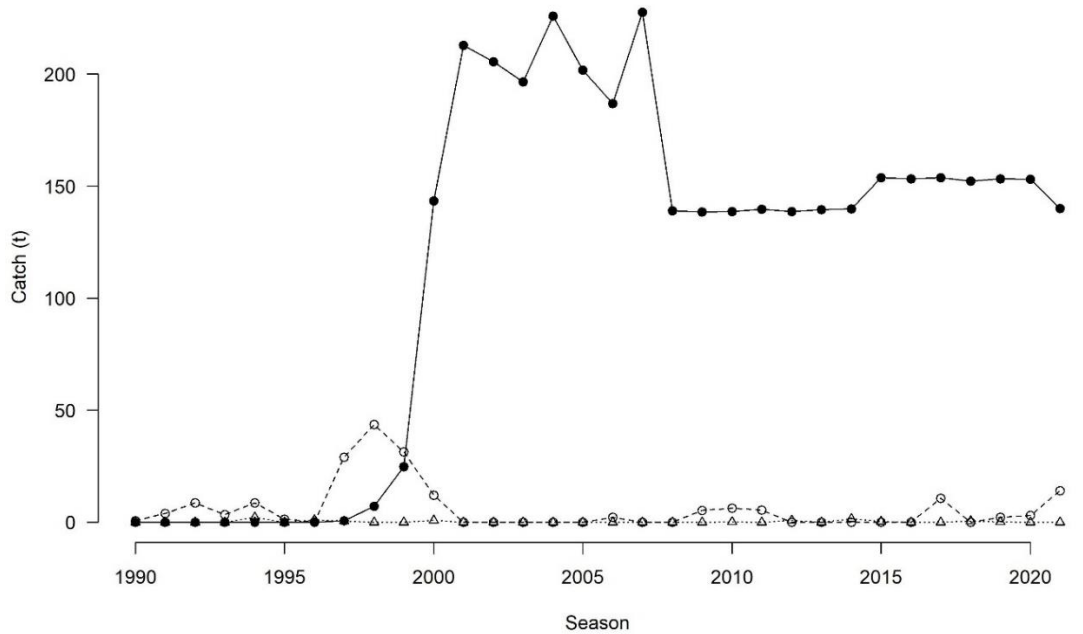

Figure 4-1 Catches of champagne (open circles), giant (open triangles) and crystal crabs (closed circles) by season (calendar year) by the WCDSCMF.

With increasing catches of deep sea crustaceans in the late 1980s and early 1990s, measures were introduced to formally manage the fishery. Expressions of interest were sought and by the end of 1993 there were 56 endorsements issued, with only seven on the west coast and the remainder on the south coast (see Section 4.2.1). These fishers fished under an exemption.

In 2000, to ensure stocks were not over-exploited, negotiations between the Department and the west coast endorsement holders resulted in three of the endorsement holders being able to fish full time, with the other four permitted to fish for up to three months. Regardless of full or part time fishing status, all seven permit holders would have equal access to fishery at the cessation of the developmental phase.

The West Coast Deep Sea Crustacean Interim Managed Fishery was formalised in 2003 with the fishery divided into five zones (Figure 4-2). Within each of the five zones, participation was restricted to either one full time and one part time permit holder, or two part time permit holders.

In 2008, a revised Interim Management Plan came into effect. The fishery transitioned to quota-based management with each of the seven permit holders having an equal share of the initial 140 t of total allowable commercial catch (TACC) of crystal crab. Quota is transferable, as it was recognised that the fishery was unlikely to support seven separate fishing operations. Along with the quota of crystal crab, a separate quota of 14 t of by-product (champagne and giant crab) was permitted to be retained. Amendments to this plan were introduced in 2012.

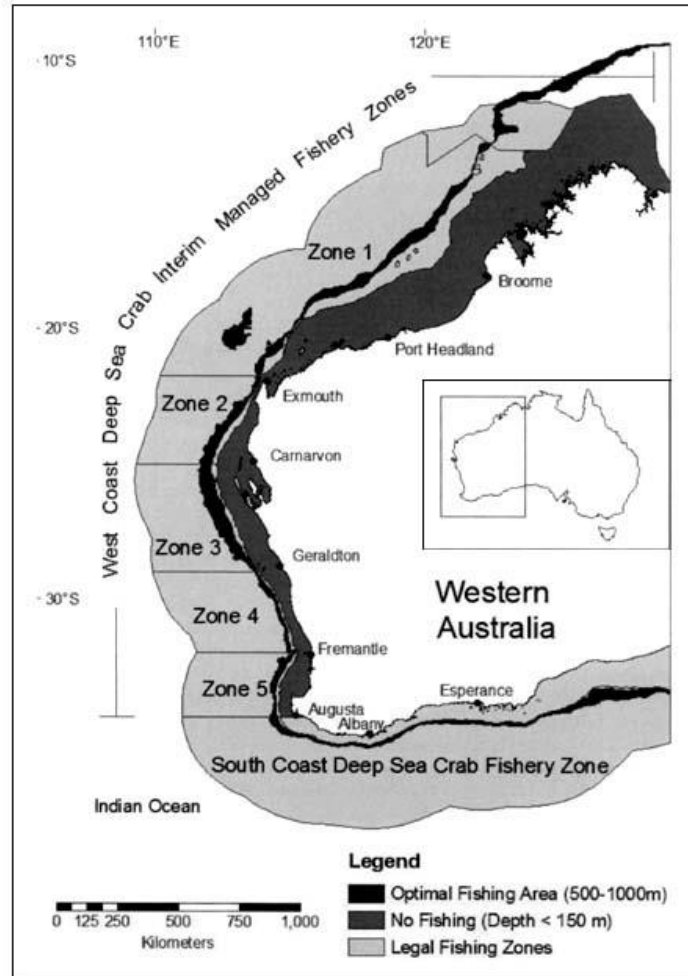

Figure 4-2 Map of the Western Australian coastline showing the management zones for the interim ‘West Coast Deep Sea Crustacean Fishery’ (2003-2008) (from Melville-Smith et al. 2007)

On 1 January 2013, the Interim Management Plan was revoked and replaced with a new Management Plan which afforded the fishery ‘fully managed’ fishery status. Since then, there have been some minor plan amendments, including the reallocation of the by-product quota into separate champagne crab quota (20.02 t) and giant crab quota (0.980 t) in 2019. The WCDSCMF received MSC certification as a sustainable fishery in 2016. In 2021 the fishery underwent the five yearly MSC reassessment with the current certificate in place until 2026.

4.1.2 Management arrangements

The WCDSCMF is regulated by the *West Coast Deep Sea Crustacean Fishery Management Plan 2012*, the *Western Australian Fish Resources Management Act 1994*, and *Fish Resources Management Regulations 1995*. A formal Harvest Strategy has been developed to support the ecological, social and economic management objectives of this fishery (DPIRD 2020).

The WCDSCMF encompasses all WA waters of the Indian Ocean and the Timor Sea north of 34° 24’ S latitude (to the Northern Territory border), on the seaward side of the 150 m isobath out to the extent of the Australian EEZ (200 nm boundary) (Figure 4-3). The WCDSCMF is open to fishing all year. Pots remain in the water throughout the year and are only retrieved to collect the catch and for rebaiting.



Figure 4-3 Location and boundaries of the WCDSCMF and specified Port Areas.

The fishery is managed with a TACC for each main species. The annual TACCs are based upon a formal harvest strategy (DPIRD 2020). The TACCs for the 2021 fishing season, spanning from 1 January to 31 December 2021, were 154 t of crystal crabs (A class units), 20.02 t of champagne crabs (B class units) and 0.98 t of giant crabs (C class units). Due to concerns around stock levels, an industry-implemented voluntary quota of 140 t was recently agreed to. TACC allocated for the current (2022) season for crystal crab was formally reduced to 123.2 t, while that for champagne and giant crabs remained at 2021 levels.

Fishers are required to report all catch (retained or discarded) to the Department through a Catch Disposal Record (CDR) and must also report any interactions with ETP species and tagged crabs.

4.1.3 Recent Fishing Activities (2021 Season)

There are seven licenses in the WCDSCMF with six vessels active in the fishery. Four vessels solely target crystal crab while two retain only champagne and giant crab. In 2021, the six active vessels undertook a combined total of 126 trips fishing for crystal crab, 33 trips for champagne crab and 1 day for giant crab. The trips were typically three days.

In 2021, the WCDSCMF landed a total of 153.96 t of the Offshore Crustacean Resource, comprised of 139.94 t of crystal crabs, 14.01 t of champagne crab and 0.01 t of giant crab (Table 4-1).

The majority of the catch from the WCDSCMF is exported to China, although there are some domestic sales in Sydney and Perth restaurants. Market demand strongly influences the fishery.

4.1.4 Fishing Gear and Methods

Fishers in the WCDSCMF are only permitted to operate using fish traps with an internal volume not greater than 0.257 cubic meters. The trap must have two escape gaps on the side of the pot adjacent to the bottom to allow undersize crabs to escape (Clause 9 *West Coast Deep Sea Crustacean Management Plan 2012*). The type and configuration of gear changes depending on the species of crab being targeted. Lost or irretrievable traps must be reported, and if a lost trap is subsequently found it is also a requirement to report it in the CDR.

4.1.4.1 Crystal crab fishing gear

Currently, WCDSCMF fishers target crystal crabs using moulded plastic rock lobster traps with a ~2 kg flat piece of metal wired to the base of the trap to act as ballast.

Traps are operated in long-lines, with 100-230 traps attached to a main line at approximately 70 m intervals. The main line is marked with floats and has additional ballast to 'anchor' each end (Figure 4-4).

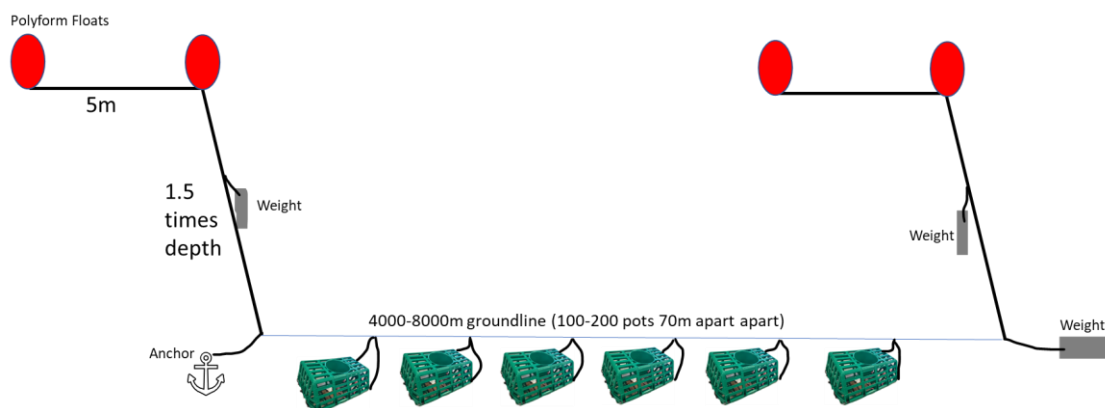

Figure 4-4 Diagrammatic representation of gear configuration for crystal crab fishing

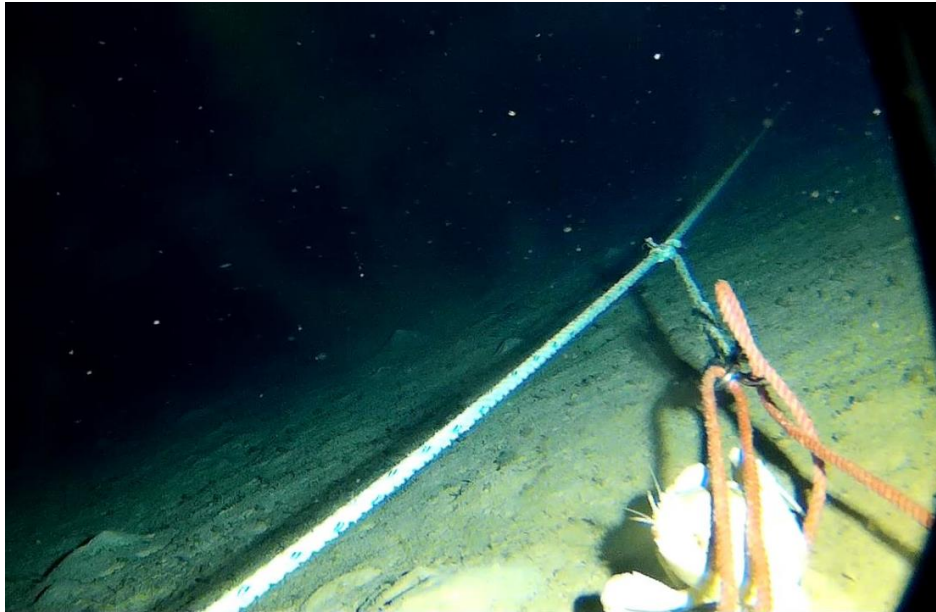

Figure 4-5 Image of WCDSCMF gear set illustrating the pots attachment to the mainline which is above the sea floor. Crystal crab in the foreground.

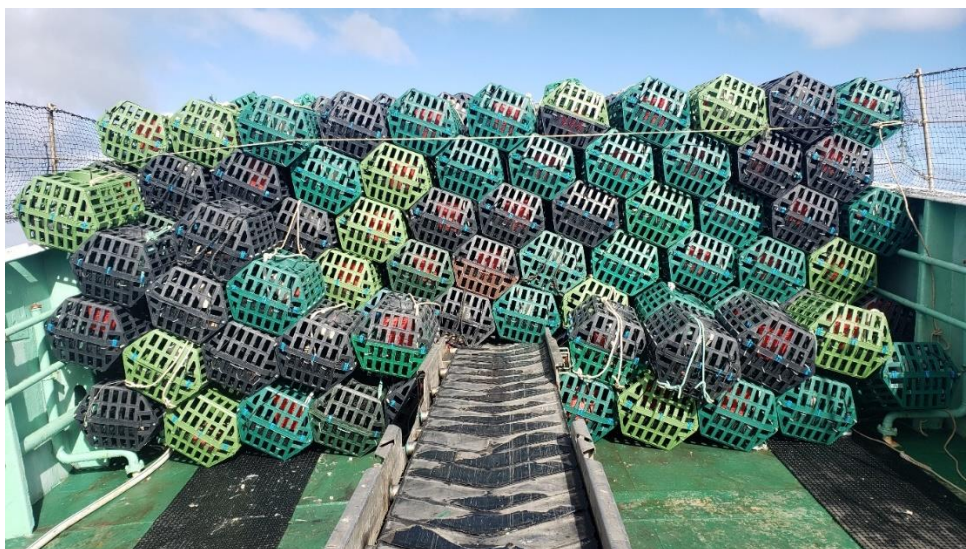

Figure 4-6 One line of stacked deep sea crustacean pots used for targeting crystal crabs.

There is little movement of the traps once they are in contact with the benthos. The rope used to connect each trap to the main line is positively buoyant, preventing any damage from rope movement across the benthos - such as occurs from 'anchor scaring' in seagrass meadows (Figure 4-5). The traps soak for three to seven days before retrieval, although on some occasions, traps can be left in the water for between 10-14 days if weather conditions are unfavourable for fishing, or for even longer periods in the event of unforeseen repairs to vessels or unfavourable markets.

Depending on the area of operation, most fishers tend to spend ~12 hours steaming to the fishing grounds, retrieving the traps at first light. Approximately 400-500 traps are pulled per day. Traps are retrieved using a hydraulic winch. Crabs are removed by hand, placed on a sorting tray, sexed and measured. Legal-sized crabs have their claws bound to their bodies using a cable tie and are tightly packed into baskets to minimise the risk of injury to both fishers and other crabs. They are placed in a 5°C brine tank for holding and transport back to port.

Any undersize crabs or female crabs that are actively breeding (with eggs) must be returned to the water as soon as possible. Retrieved traps are re-baited and stacked on deck. Vessels can typically store a maximum of 2 to 3 lines on board before they must reset (Figure 4-6). Due to the low productivity of the fishery, fishers typically re-set traps on different ground to where they were retrieved.

4.1.4.2 Champagne crab gear

Fishers targeting champagne crab also fish pots in a longline configuration, though they are considerably shorter than those targeting crystal crabs (Figure 4-4). Strings of typically six pots are spaced ~70 m apart on a longline and marked with a single mainline to two surface floats (Figure 4-7). Fishers also use a wooden slat pot which is used in the WCRLMF (Figure 4-22) to retain champagne crabs as opposed to the plastic pots used for crystal crabs (Section 4.3.4).

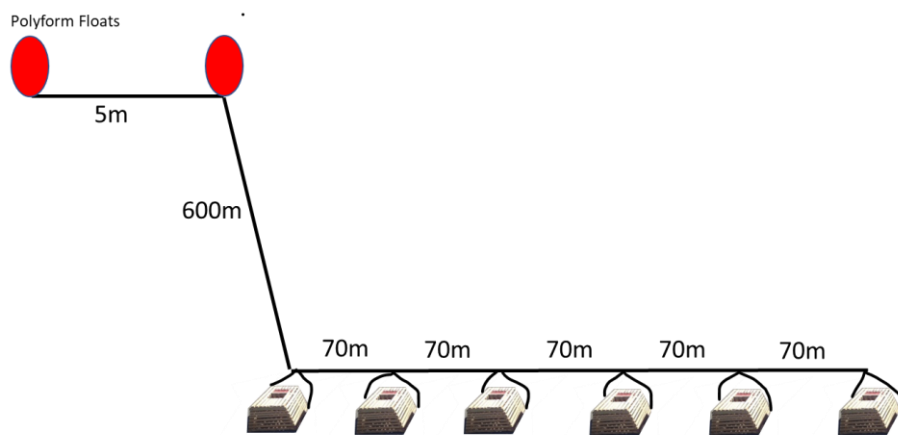

Figure 4-7 Diagrammatic representation of gear configuration for champagne crab fishing

4.1.4.3 Giant crab gear

There is more variation in the construction and configuration of gear when fishing for giant crabs. According to some fishers, the ideal construction (Figure 4-8) utilises three wooden slat pots (Figure 4-22) marked by a single mainline to two floats. However, other fishers will modify a crystal crab rig (Figure 4-4) using up to 40 pots marked by a single mainline. Some fishers also use steel frame “beehive” pots covered in either trawl mesh or chicken wire (Figure 4-9) in varying longline configurations.

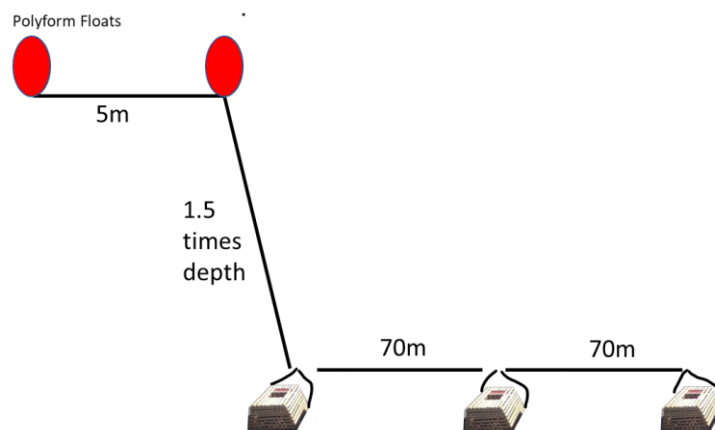

Figure 4-8 Diagrammatic representation of a gear configuration for giant crab fishing.



Figure 4-9 Two examples of steel frame “beehive” pots covered with trawl mesh (left¹) and chicken wire (right²).

4.1.4.4 Bait

The WCDSCMF used 77.1 t of bait in the 2021 season, with New Zealand blue mackerel being the main bait species used by the fishery (Table 4-2). There has been a progressive increase in bait usage by this fishery (Figure 4-10), which coincides with the increasing effort over the same period (Figure 4-11).

Table 4-2 Species, origin, type and amount of bait (kg) used during the 2021 fishing season by the WCDSCMF.

Bait	Origin	Type	Amount (kg)
Blue Mackerel	New Zealand	Whole	44,248
Hoki	New Zealand	Heads	11,498
Pilchards	Western Australia	Whole	9,600
Pilchards	New Zealand	Whole	5,600
Orange Roughy	Australia	Heads	4,200
Australian Salmon	Western Australia	Cutlets	1,200
Mullet	Western Australia	Whole	800
TOTAL			77,146

4.1.4.5 Landing process

Upon returning to port, fishers are met by a processor with a refrigerated truck to transport the catch. Catches are unloaded from the vessel and weighed before being transported to an approved processing facility, where they are reweighed. In accordance with the management plan, the weight of landed catch is recorded in triplicate in a CDR form before being dispatched to the processor. Comparison of landed weights and processor weights are used for validation by the Department. Separate CDRs and hence weights are required for each species being landed.

¹ <https://www.abc.net.au/news/2022-03-02/lobster-pot-environmental-impact-plastic-free-warrnambool/100871510> (accessed 9 Nov. 22)

² <https://www.facebook.com/southernmarinebrokers/posts/for-sale-3-tasmanian-rock-lobster-pots-85000eapls-call-0428-822-566-for-more-inf/2783418541749831/> (accessed 9 Nov. 22)

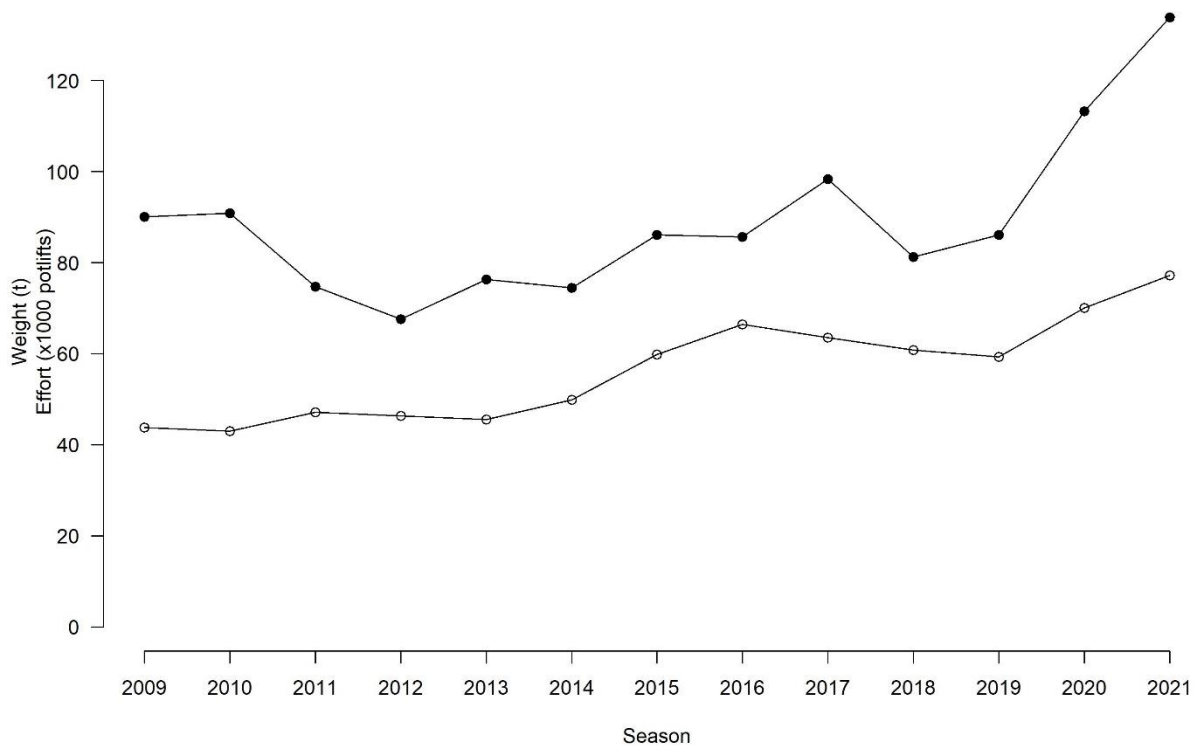

Figure 4-10 Seasonal bait usage (tonnes; open circles) and effort (x1000 potlifts; closed circles) for the WCDSCMF.

4.1.5 Fishing effort

Nominal fishing effort peaked in the 2000 season at almost 250,000 pot lifts (Figure 4-11). Subsequently, effort levels declined and have remained less than 100,000 pot lifts per season for a decade since the 2009 season. From 2012, there has been a steady increase in the effort in the fishery. The majority of effort since the expansion of the fishery has been targeted toward crystal crabs (Figure 4-11). The recent separation between total effort (filled circles) and crystal crab effort (open circles) highlights the recent additional targeting of champagne crab (Figure 4-11).

The current Harvest Strategy for the WCDSCMF (DPIRD 2020) contains two effort-based indicators that are part of a suite of performance indicators used to assess potential impacts of the fishery on habitats and the broader ecosystem. These indicators are i) area fished annually (number of blocks) and ii) annual effort level (number of trap lifts). Threshold reference levels for these two indicators are >125 blocks and >169,000 trap lifts per year, respectively, which are based on peak levels recorded during the reference period 2003-2012. In recent years there have been increases in both indicators, although both remain below threshold levels (Figure 4-11, Figure 4-12).

During the reference period the fishery was under zonal management (Section 4.1.1) and hence had a broader spatial distribution of effort and catch (Figure 4-13). The increasing trend in the number of blocks being fished since the removal of zones indicates that individual fishers are progressively spreading their effort over a larger area each year (Figure 4-12).

Fishing for crystal crab is restricted to a fairly narrow depth band, with 95% of all fishing occurring in a 250 m depth band from 450 to 700 m (Figure 4-14). Depth of fishing has shifted gradually as the fishery has developed from a mean depth of ~750 m initially to ~580 m in recent seasons. The trend appears to have stabilised in recent years indicating that the optimal depth of fishing has been determined by fishers (Figure 4-14). Fishing for champagne crab

has been more sporadic (Figure 4-1), but clearly exists at a shallower depth than for crystal crabs (Figure 4-14).

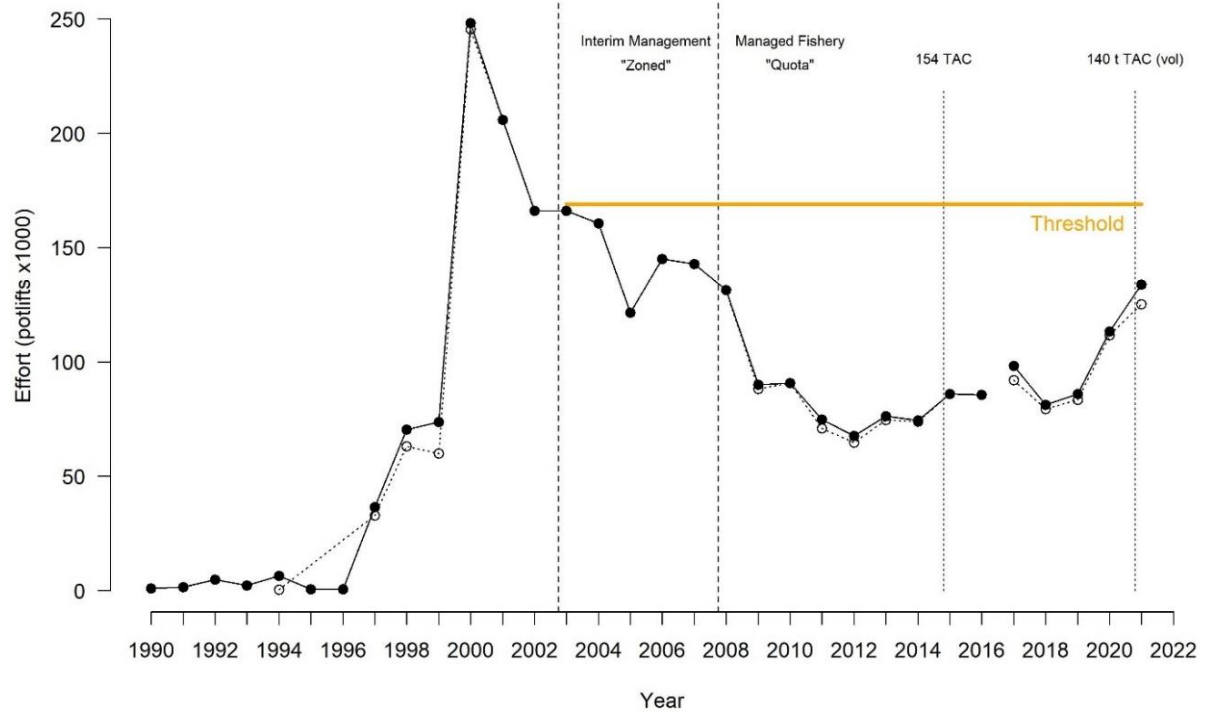

Figure 4-11 Annual nominal effort (potlifts) for all fishing in the WCDSCMF (closed circles, black line) and fishing for only crystal crab (open circles, dotted line) and the associated threshold (orange) reference level. Time series break (2017) due to a change in mandatory reporting from monthly to by-line.

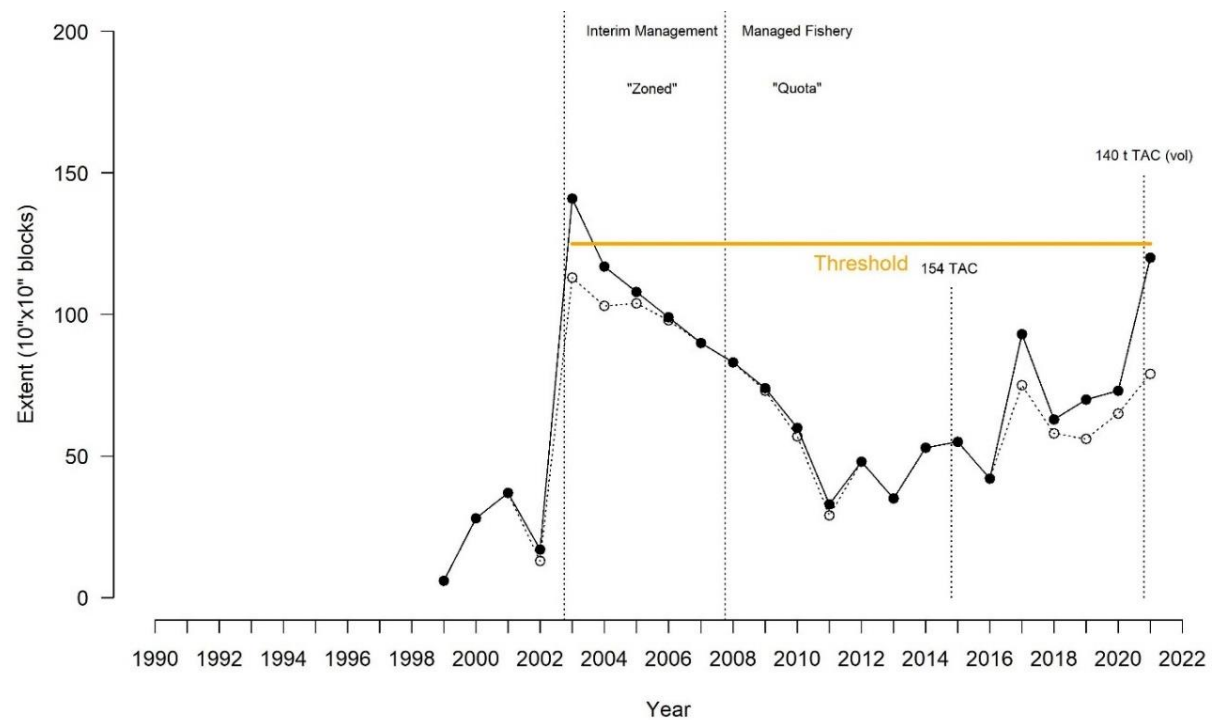

Figure 4-12 Annual spatial extent (number of 10x10 nm blocks) of all fishing (filled circles) and crystal crabs (open circles) and the associated threshold (orange) reference level.

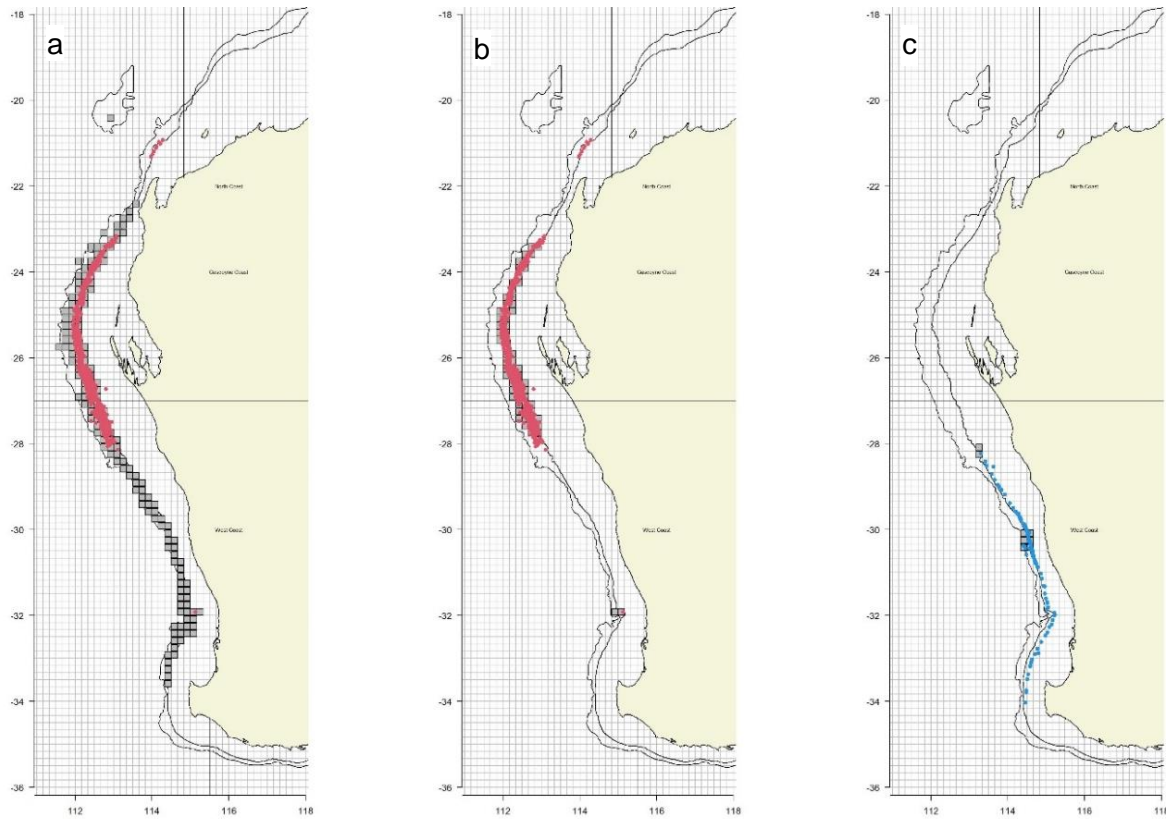

Figure 4-13 Location of fishing effort in 2021 for crystal (red dots) and champagne (blue dots) crabs with the 10x10 nm blocks fished (grey) during a) the reference period of 2003-2012, b) 2020 season for crystal crabs and c) 2020 season for champagne crabs.

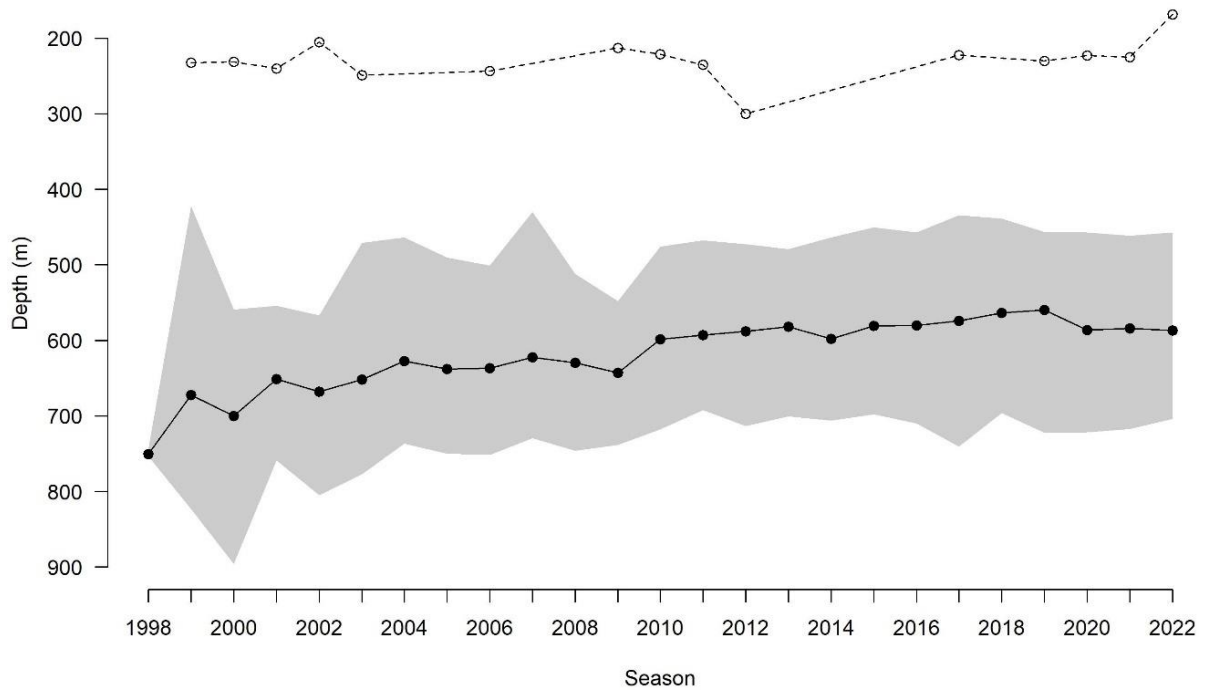

Figure 4-14 Mean (line) and 95% CI (grey shaded) depths of crystal crab (closed circles) and champagne crab (open circles) catches by year.

4.2 South Coast Crustacean Managed Fishery (SCCMF)

4.2.1 History of Development

Fishing for offshore crustaceans on WA's south coast began in the late 1960s, with the Windy Harbour Augusta region (subsequently the Windy Harbour-Augusta Managed Fishery [WHARLMF]) being fished by full-time and part-time fishers since the late 1970s. The fishery primarily landed rock lobsters (southern and western), with landings of deep sea crabs (champagne, giant and small amounts of crystal crab) beginning to appear in the commercial catch landing statistics around the early 1990s.

The south coast offshore crustacean fishery came under formal management with the establishment of the WHARLMF and the Esperance Rock Lobster Managed Fishery (ERLMF). Access outside these managed fisheries to the Resource was through a pot regulation (Regulation 95) to take rock lobster and a condition attached to a fishing boat licence (Condition 105) which permitted the take of deep sea crabs. This regulation and condition permitted access in both the Albany and Bight regions and the retention of deep sea crabs outside of the lobster season (15 November – 30 June) in the WHARLMF (Figure 4-15).

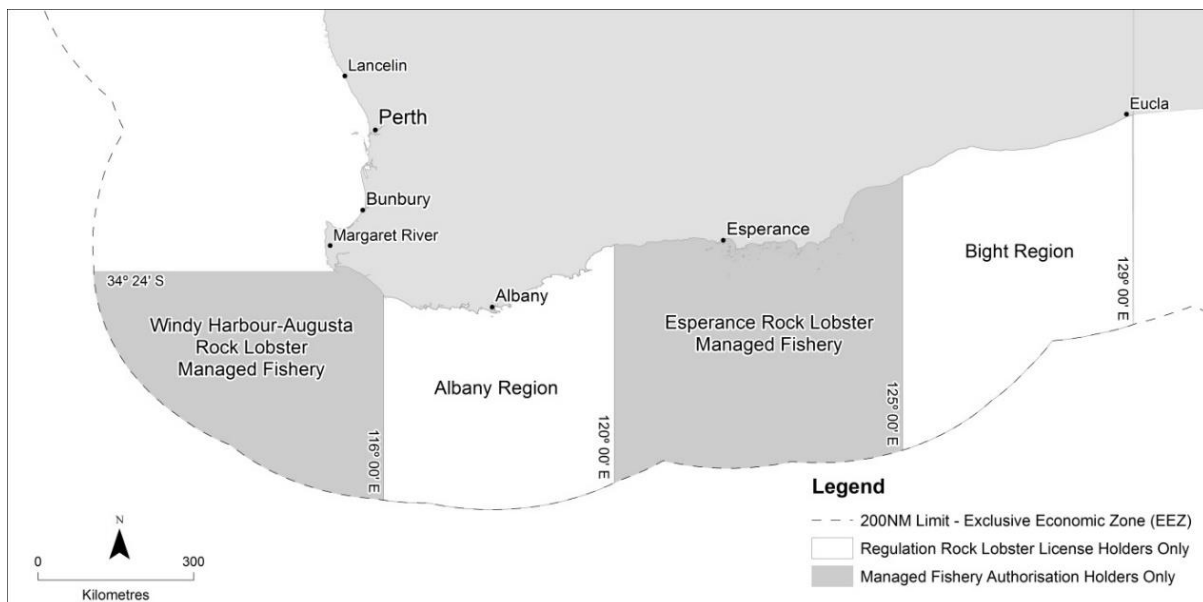

Figure 4-15 Map indicating the managed fisheries or fishing regions which ultimately comprised the SCCMF.

The formalisation of management arrangements for the Albany and Bight Regions occurred through their combination with the WHARLMF and ERLMF to form the South Coast Crustacean Managed Fishery (SCCMF) in 2015. An access and allocation process was undertaken in the Albany and Bight Regions to address considerable latent effort in these regions. Additionally, due to a lack of access to the offshore component of the Bight Region, an additional Offshore Bight Zone was established which permitted equal access by any SCCMF license holder (Figure 4-16) to deep sea crabs only. The fishery was managed by a total allowable effort (TAE), with a closed season for rock lobsters (both southern and western) between 1 July and 14 November. Deep sea crabs could be retained year-round, except within Zone 3 (Esperance) where fishing was restricted to the same season as for rock lobster.

4.2.2 Management arrangements

The SCCMF is regulated by the *South Coast Crustacean Managed Fishery Management Plan 2015*, the *Western Australian Fish Resources Management Act 1994*, and *Fish Resources Management Regulations 1995*.

The SCCMF encompasses the waters from Augusta to the South Australian border containing five management zones (Figure 4-16) that, until 2022/23, each had specified input unit allocations (Table 4-3). For the 2022/23 season (starting 1 July 2022) the fishery transitioned Zones 1 to 4 to output controls under an Individual Transferable Quota (ITQ) system, with allocated TACC for each of the five species (southern and western rock lobster and crystal, champagne and giant crab) in each of the four coastal zones (Table 4-4). The Offshore Bight Zone remains a development area of the fishery without TACC limits. In the transition to ITQ, the fishing season was expanded to permit fishing for all five target species year-round across the whole fishery.

After each trip, fishers are required to report all catch (retained or discarded) to the Department through a Catch Disposal Record (CDR) and must also report any interactions with ETP species and tagged crabs.



Figure 4-16 Boundaries and zones of the SSCMF and Sea Lion Exclusion Device (SLED) areas.

Table 4-3 Location of SSCMF fishing zones, with the associated pot allocations immediately prior to 2022/23 season. *Pot limits were eased after the transition to ITQ.

Zone	Area	Previous Capacity*
Zone 1 (Windy Harbour – Augusta)	34° 24' S – 116° E	350
Zone 2 (Albany)	116° – 120° E	653
Zone 3 (Esperance)	120° – 125° E	544
Zone 4 (Inshore Bight)	125° – 129° E	430
Offshore Bight Zone	125° – 129° E	200 pots per MFL

Table 4-4 Species and their total allowable commercial catch (TACC) under the ITQ system in each of the four coastal zones of the SSCMF.

Species	Zone1	Zone 2	Zone 3	Zone 4
Western Rock Lobster	35,000 kg	6,530 kg	1,050 kg	430 kg
Southern Rock Lobster	700 kg	1 000 kg	16,000 kg	14,000 kg
Crystal Crab	910 kg	6,000 kg	4,000 kg	430 kg
Giant Crab	1,505 kg	2,000 kg	2,500 kg	430 kg
Champagne Crab	3,000 kg	5,000 kg	4,000 kg	430 kg

4.2.3 Recent Fishing Activities (2021/22 Season)

In 2021/22, the SCCMF had six active vessels that fished for a total of 215 days. In 2020/21, the fishery landed a total of 22.1 t of the Offshore Crustacean Resource, comprised of 6.8 t of southern rock lobster, 0.9 t of crystal crabs, 5.5 t of giant crabs and 8.9 t of champagne crabs (Table 4-1). It also landed 5.3 t of western rock lobster. There was a voluntary catch limit in place for all target species except WRL in Zone 3 which limited the catch.

4.2.4 Fishing Gear and Methods

The SCCMF uses ‘pots’ that are mainly steel-frame beehive pots with chicken wire or trawl mesh (Figure 4-9), plastic ‘elvinco’-style pots (Figure 4-6) or west coast rock lobster batten pots (Figure 4-22).

All rock lobster pots used in WA are limited in dimension or composition in accordance with Schedule 13 of the *Fish Resources Management Regulations 1995*. The dimensions of rock lobster pots must not exceed 1000 mm in diameter (width) or 500 mm in height. The pots must have only one entrance on the upper surface, and when used in the SCCMF have at least one escape gap positioned on the side opposite the hauling rope and adjacent to the base. Additional alterations to fishing gear have been specifically implemented at certain locations or times of the year to reduce interactions with ETP species.

SCCMF fishing locations extend from shallow inshore waters to beyond the edge of the continental shelf. Pots are set in a variety of configurations that change with the depth of water being fished and species targeted. In shallow waters, when targeting rock lobster, pots are usually set on an individual basis (Figure 4-17). As the water gets deeper, fishers will often use multiple pots per line (Figure 4-7, Figure 4-8). In very deep water when targeting crabs, the pots are usually set in long-line configurations with up to 60 or more pots on one line (Figure 4-4).

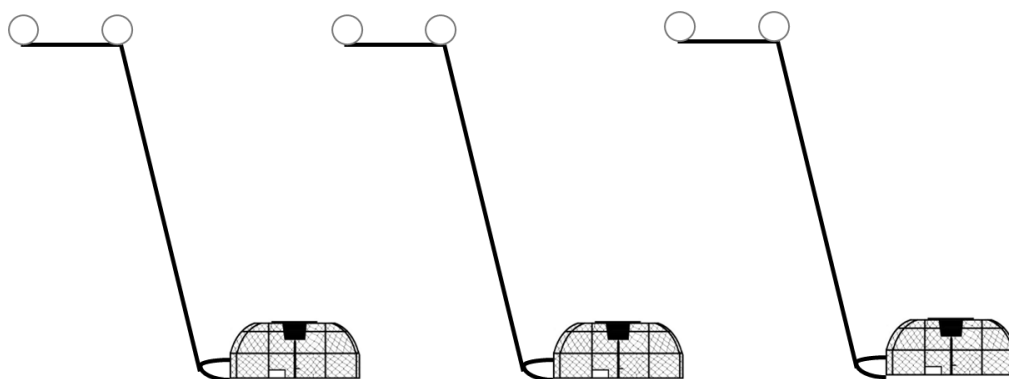

Figure 4-17 Diagrammatic representation of gear configuration for southern rock lobster fishing.

Pots are generally set for between one and three days, during which time lobsters and crabs are attracted to the baits and enter the pots. Captured lobsters and crabs of legal size and appropriate reproductive status (e.g. not berried) are placed into holding tanks and returned to on-shore processing plants. Any undersize individuals are returned to the water as soon as possible. In some areas and during some times of the year, pots are left fishing for a number of days before retrieval. Pots are removed from the water when fishers are not actively fishing. During the period starting on 1 April and ending on 30 November each year, pots must be pulled at least once every 10 days to ensure pots are actively fished or removed from the water if not, to reduce the risk of potential whale entanglements. The vast majority of lobsters and crabs are shipped live to overseas, with the remainder sold on interstate and local markets.

4.2.4.1 Bait

Bait data was recorded from the 2019/20 season. Fishers record the type of bait used but are not required to provide quantities. The dominant species used by SCCMF fishers was blue mackerel and hoki heads, with pig fat also used as a holding bait (Table 4-5). The source of the bait is also not recorded by fishers and is supplied from processors in other fisheries. Given the capture location of bait used in other similar fisheries (WCRLMF and WCDSCMF), it is likely that blue mackerel, hoki heads, (orange) roughy and barracouta heads are sourced from New Zealand, with the rest of the bait being locally (WA) sourced.

The overall composition of bait used by the SCCMF is very similar to that used by the WCDSCMF, which used a total of 77,146 kg of bait for the 133,827 potlifts during the 2021 fishing season, averaging 0.58 kg/potlift. The WCDSCMF uses bait pouches in plastic pots (Figure 4-6) when fishing predominantly for crystal crabs (Figure 4-1). This is likely to require a lower bait usage than the SCCMF, which uses different pots (see above) with larger bait baskets. Assuming daily bait usage by the SCCMF of 1kg / potlift, which is almost double that of WCDSCMF usage, then an estimated 21,634 kg of bait (21,634 potlifts @ 1kg / potlift) could have been used in the SCCMF during the 2021/22 season, noting that this is likely an overestimate. It should also be noted that effort (and hence bait use) in 2021/22 was relatively low compared to other years.

Table 4-5 Bait species and the number of trips they were reported used by SCCMF fishers by financial year and overall.

Bait Species	2019/20	2020/21	2021/22	Total
Blue Mackerel	96		51	147
Hoki Heads	120	3	16	139
Pig Fat	63		31	94
Salmon	63	3	20	86
Albany Mullies	67	4	9	80
Triggerfishes & Leatherjackets	25		5	30
Roughy	8		8	16
Couta heads	2			2
Herring			2	2
Breams			1	1
Mullet		1		1

4.2.5 Effort

Total effort increased markedly in the SCCMF in the early 1990s to an overall high of >500,000 potlifts, with each zone experiencing an increase in effort (Figure 4-18). There were two marked peaks in effort, during the early-mid 1990s and early 2000s, driven by increased effort in Zones 1 and 2 (Figure 4-18). Total effort then fluctuated and mostly remained between 200,000 – 350,000 potlifts until the 2019/20 season when a considerable decline occurred as a result of the COVID-19 pandemic, market and supply chain related issues. Effort in the 2021/22 season was ~10% of that just three years earlier (Figure 4-18).

Under previous reporting requirements fishing data was reported at 60 x 60 nm blocks. More detailed spatial data (10 x 10 nm blocks) is available since 2019/20 when trip returns were implemented. Despite the marked decline in effort since this level of reporting was introduced (Figure 4-18), it is evident that effort is widely distributed throughout the fishery area. Effort occurs inshore and offshore in Zones 1 and 3, whereas most of the Zone 2 effort is offshore and Zone 4 effort is coastal (Figure 4-19). It should be noted that due to the marked effort reduction in recent years, this current distribution may not fully represent effort in the SCCMF under a higher level of fishing.

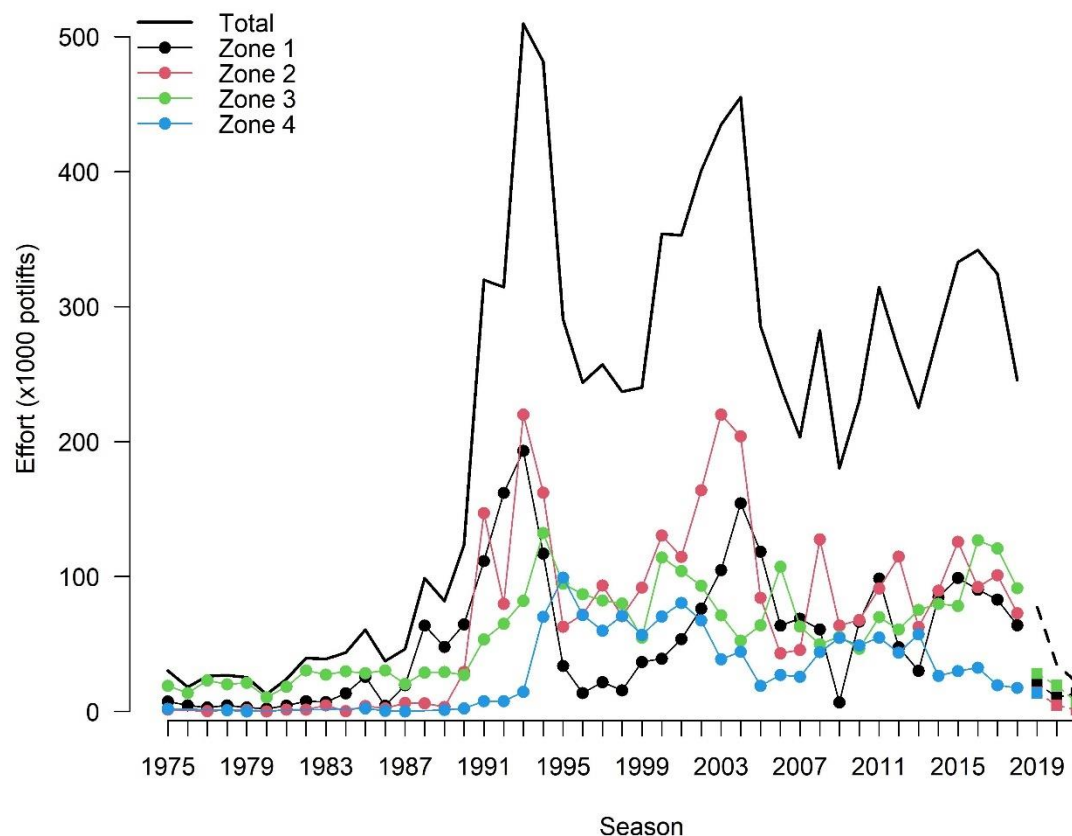

Figure 4-18 Total and zonal seasonal potlifts in the SCCMF.

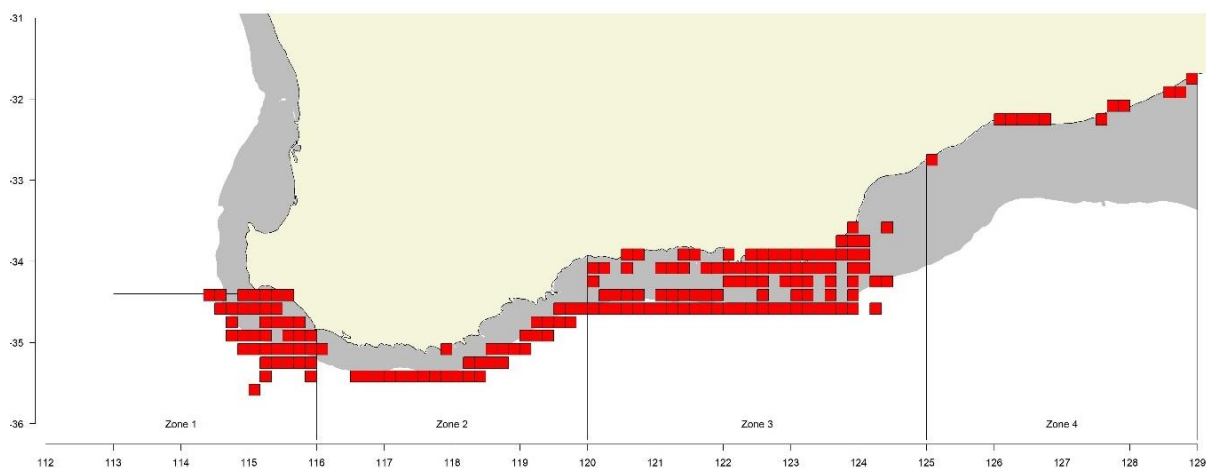

Figure 4-19 Location of fishing (red squares) in the SCCMF for the last three seasons (2019/20 – 2021/22). Grey indicates waters <200 m deep.

4.3 West Coast Rock Lobster Managed Fishery (WCRLMF)

4.3.1 History of Development

A full description of the history of the WCRLMF can be found in de Lestang *et al.* (2016).

The WCRLMF was one of the first managed fisheries in Australia, and the world, with management regulations implemented for harvesting of western rock lobster (*Panulirus cygnus*; WRL) in 1897 (de Lestang *et al.* 2012). The WCRLMF captures WRL along the WA west coast, with its boundary extending from Cape Leeuwin to North West Cape and comprising three fishing zones (Figure 4-20).

The fishery was declared limited entry in March 1963 when licence and pot numbers were capped. Since 1963, boat numbers have declined from 836 to approximately 235 (in 2021) due to management changes (pot reductions, etc.) and consolidation for economic efficiencies (Figure 4-21). There was a significant drop in vessel numbers in 2008/09 and 2009/10 associated with the effort reductions. In recent seasons vessel numbers have remained at ~230 vessels, which typically pull around 100 pots per trip.

From the 1980s to the mid-2000s, the annual catch averaged approximately 11,000 t, although it varied from 5,800 t to 14,000 t based on levels of recruitment (Figure 4-21). Initially an input-controlled fishery, it transitioned to an output managed fishery in 2009/10 with a TACC of 5,500 t ($\pm 10\%$). This TACC was maintained for the 2010/11 season using individual transferable quotas (ITQs). The transition of the fishery from effort-based management controls to an ITQ management framework was finalised in 2012 with the implementation of the *West Coast Rock Lobster Managed Fishery Management Plan 2012*.

This transition was in response to a historically low recruitment period commencing in 2007 which necessitated a marked reduction in total annual catch, from averages of ~11,000 t under effort controls, to around ~5,500 t under quota. Since then, recruitment has improved and there has been a marked increase in biomass. However, catches have remained at ~6,000 t for commercial marketing and economic reasons.

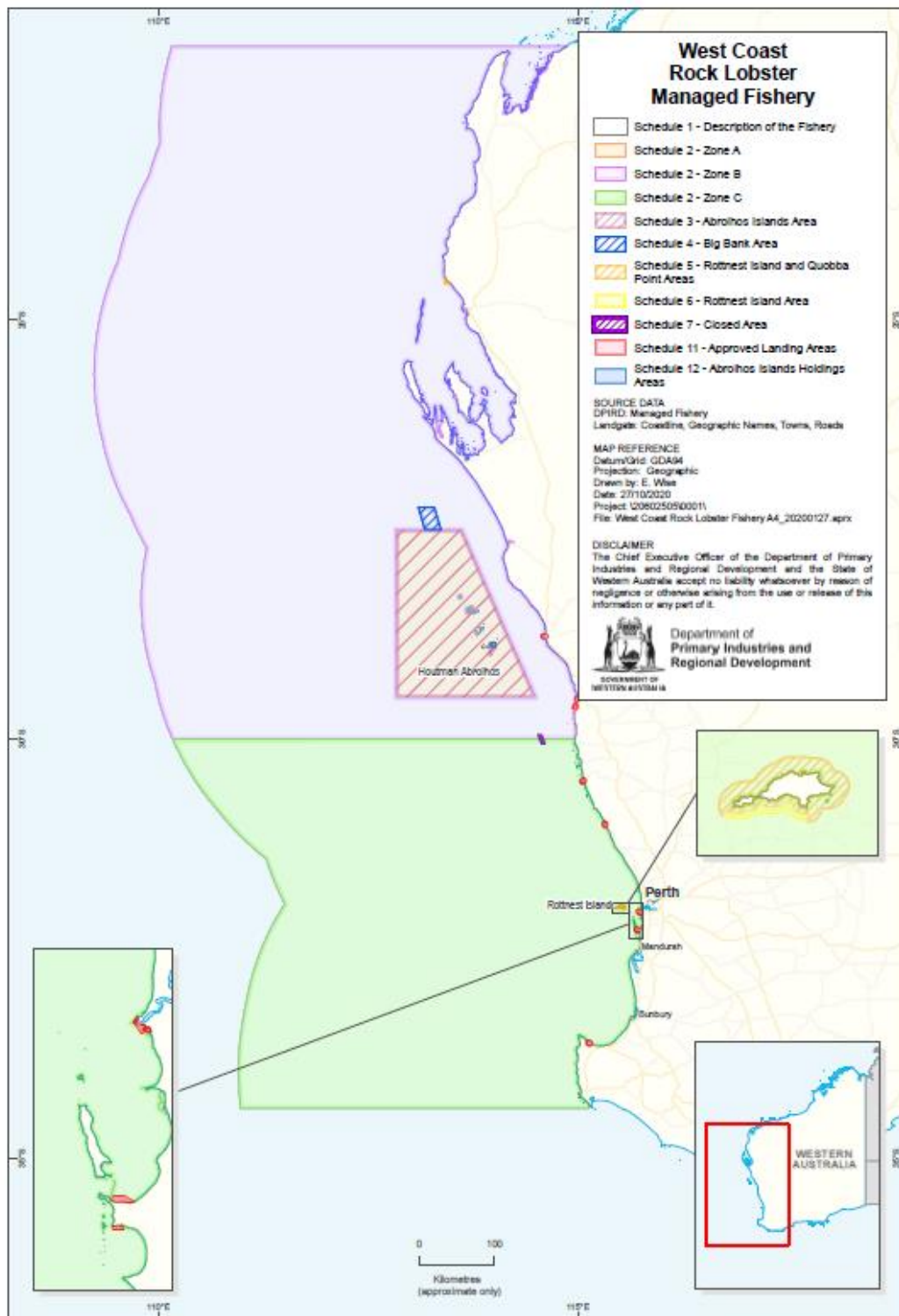

Figure 4-20 Management boundaries of the WCRLMF.

The improved biomass and limited catch have seen a marked reduction in effort. From the 1970s through to the mid-2000s, the WCRLMF had in excess of 9 million pot lifts per season. This dramatically declined through the late 2000s with the series of effort controls and transition to quota. This has resulted in less than 3 million pot lifts in recent seasons (Figure 4-21).

Traditionally, the fishing seasons for Zones B and C of the WCRLMF operated from 15 November to 30 June annually, while Zone A, the Abrolhos Island zone, operated from 15 March to 30 June. From 2010/11, there was a progressive increase in season length, until year-round fishing occurred in 2013. Since then, fishing in every zone has commenced on 15 January and finished on 14 January the following year, with seasons referred to by the year in which they began. The exceptions were two extended 18 month 'seasons' which were implemented to address COVID-19 and market closure impacts on the fishery. These seasons ran from 15 January 2020 to 30 June 2021 and 1 July 2021 to 14 January 2023, with a pro-rata quota equivalent to ~6,600 t p.a.

The WCRLMF was first declared an approved Wildlife Trade Operation (WTO) in August 2002, in accordance with Parts 13 and 13A of the *Environment Protection and Biodiversity Conservation Act 1999* (EPBC Act). The WCRLMF has since been reassessed several times, most recently in 2018. This accreditation allows continued export of product from the fishery. As a result of the development and implementation of effective whale mitigation measures (How *et al.* 2021), the requirement for three yearly assessments was removed and the fishery was moved to a 10-year assessment schedule. The next WTO assessment is due to occur in May 2025.

The WCRLMF was the first fishery in the world to receive MSC certification as a sustainable fishery in 2000 and was recertified in 2006, 2012, 2017 and 2022.

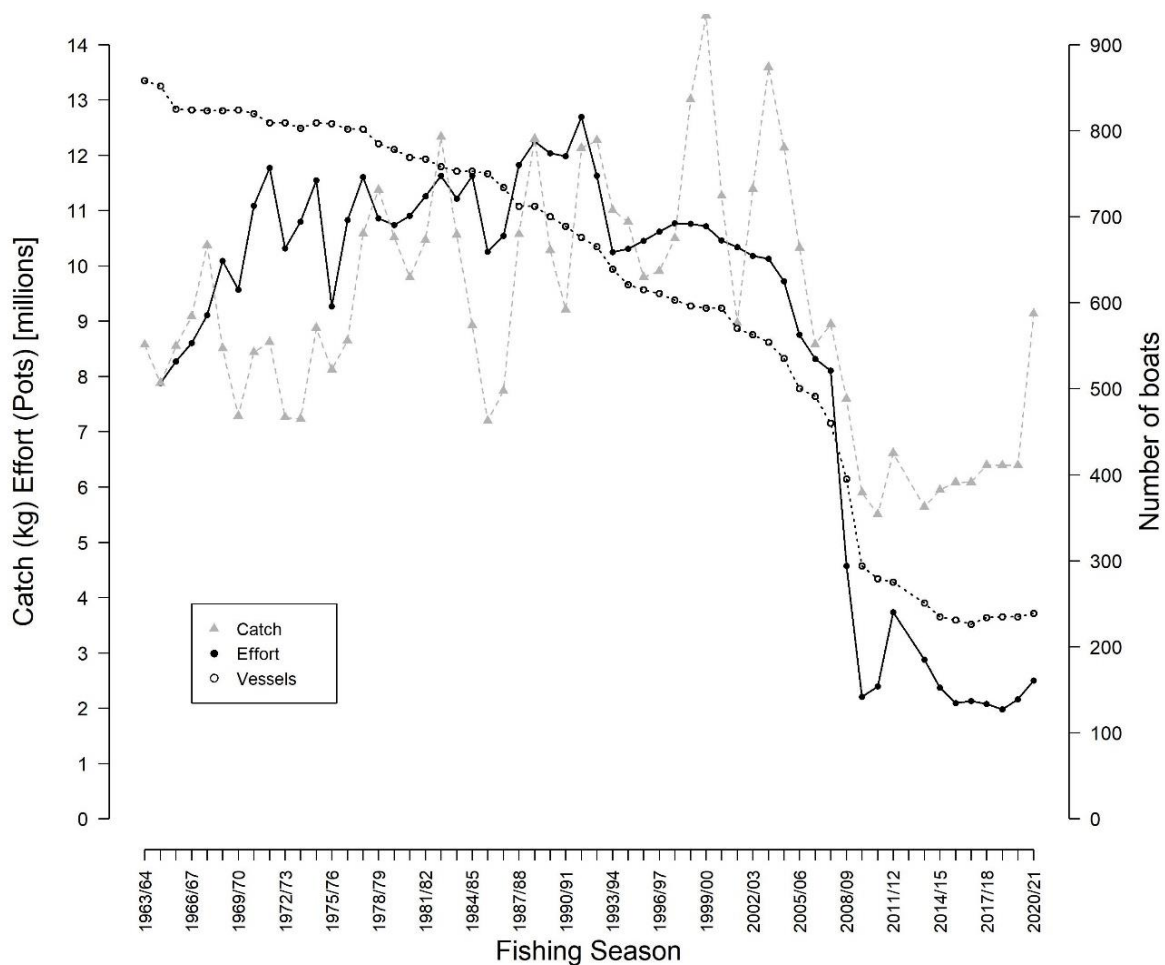

Figure 4-21 Seasonal catch, effort and number of vessels in the WCRLMF.

4.3.2 Management arrangements

The WCRLMF is regulated by the *West Coast Rock Lobster Managed Fishery Management Plan 2012*, the *WA Fish Resources Management Act 1994*, and *Fish Resources Management Regulations 1995*.

The WCRLMF is managed in three zones: within the Abrolhos Islands zone (Zone A), north of latitude 30° S (Zone B), and south of latitude 30° S (Zone C) (Figure 4-20). This zoning arrangement distributes effort relatively evenly across the entire fishery and allows for the implementation of management controls aimed at addressing zone-specific issues, which has previously included different maximum size restrictions in the northern and southern regions of the fishery.

The WCRLMF is primarily managed via output controls by way of an ITQ management system which limits the amount of WRL that can be harvested within the TACC limit. The management framework also limits the number of pots which may be used under each licence, calculated based on the number of ITQ units. WCRLMF entitlement units are conferred as kilograms within one of the three zones.

Until recently, almost all product was “live” and exported predominantly to China. The outbreak of COVID-19 resulted in the effective closure of the live lobster trade to Asia in late January 2020. As a result of this dramatic reduction in demand, operators in the WCRLMF essentially stopped fishing from late January until the end of March 2020.

To account for these major perturbations to the industry, a TACC (9,000 t) was recently allowed to be caught over two extended (18 month) seasons: 15 January 2020 to 30 June 2021, and 1 July 2021 to 14 January 2023. The fishery will transition to a new financial year season structure from 1 July 2023. Therefore, there will be a one-off 5.5-month transition season from 15 January to 30 June 2023.

Rock lobsters are totally protected at some stages in their lifecycle. When lobsters are protected, fishers must not take them or have them in their possession. Fishers are required to immediately return undersize, berried and/or tarspot lobsters to the water from which they were taken, before the next pot is pulled and before taking another lobster when diving. For the commercial sector, rock lobster with setose (fine hair-like filaments underneath the tail) are commercially protected between 1 November and 30 April the following year.

At the end of each trip, WCRLMF fishers are required to report all catches, including quantities of all retained species and discarded (high graded) rock lobsters to the Department in a CDR and any interactions with ETP species.

4.3.3 Recent Fishing Activities (2021 Season)

There are currently 720 licences in the WCRLMF, with ~235 boats actively fishing for western rock lobster. In the 2021 season, only 20 vessels reported catches of champagne crabs, from a total of 157 vessel days of fishing.

In 2021, the fishery landed a total of 1.5 t of the Offshore Crustacean Resource, comprised entirely of champagne crabs (Table 4-1). It also landed 6,334 t of western rock lobster.

4.3.4 Fishing Gear and Methods

All lobsters are captured using baited pots. These are typically a wooden batten pot which formerly had very specific restrictions on their dimensions (Figure 4-22). The majority of pots used by fishers are still made to these dimensions despite a change to the regulations in 2016. In an attempt to provide greater flexibility for fishers and reduce regulation, the specified dimensions of a pot were changed to specify that a rock lobster pot must not exceed 1000 mm

in diameter (width) and 500 mm in height (Schedule 13 of the *Fish Resources Management Regulations 1995* (FRMR)).

Pots are set on or adjacent to limestone reef, or on sand-dominated migratory pathways of rock lobsters at certain times of the year. They are marked by surface floats which are attached to the pots through lines (plastic rope). These lines are used to haul the pots which are set mainly between 1 – 7 days. When accessing the Offshore Crustacean Resource which resides in deeper water, fishers typically utilise short strings of lobster pots (Figure 4-7) for increased fishing efficiency. Additional alterations to fishing gear have been specifically implemented at certain locations or times of the year to reduce interactions with ETP species.

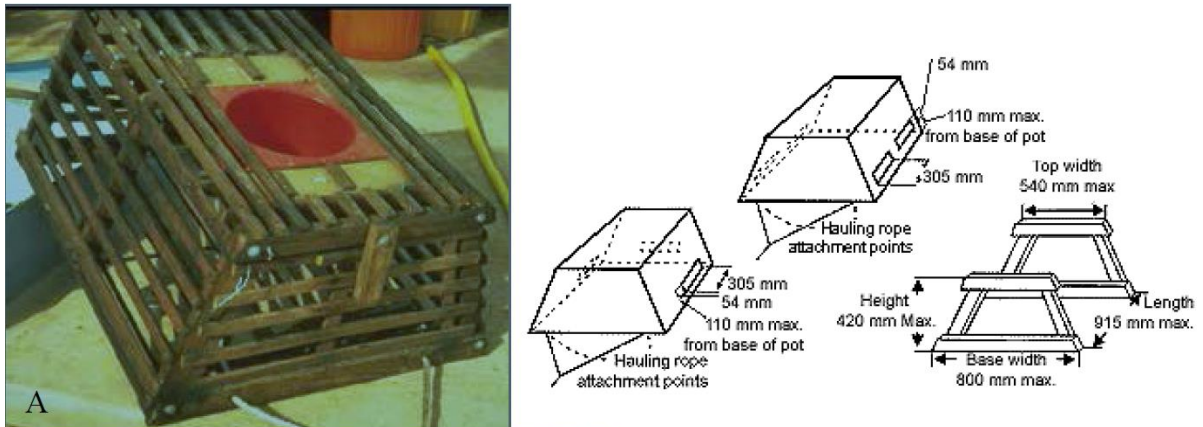

Figure 4-22 Image of a western rock lobster pot (left) and the previous specified dimensions of pots (right) which are the size of most pots in the WCRLMF.

4.3.4.1 Bait

Fishers use a range of fish bait species, with pig fat / flare also used as a “holding” bait. The fishery used 2,496 t of bait in the 2020 season which were sourced either locally (WA) or from New Zealand (Table 4-6). The significant decline in effort (Figure 4-21) coupled with a considerable increase in the biomass of WRL (legal sized biomass has increased from ~12,000 t in 2000 to 26,000 t in 2021) has seen subsequent bait usage decline (Figure 4-23).

The majority of catch of the Offshore Crustacean Resource is retained from December to February in waters ≥ 70 fathoms (128 m; Figure 5-7). During 2020, 47,549 potlifts were recorded in these months and depth representing 2.9 % of the total (1,618,531) potlifts for the WCRLMF in that year. Assuming equal bait usage per potlift through the year, this would equate to ~73.3 t of bait used when accessing the Resource.

Table 4-6 Identity, origin, type and total amount of bait (kg) used by the WCRLMF during the 2020 fishing season, and the approximate amount of bait used while accessing the Offshore Crustacean Resource (OCR).

Bait	Origin	Type	Total WCRLMF amount (kg)	Approx. bait used for OCR (kg)
Blue Mackerel	New Zealand	Whole	633,915	18,623
Salmon	Western Australia	Cutlets	49,868	1,465
Kahawai	New Zealand	Whole	12,400	364
Hoki	New Zealand	Heads	1,017,556	29,893
Orange Roughy	New Zealand	Heads	521,065	15,307
Pork Flare	Western Australia		117,625	3,455
Alfonsino	New Zealand	Heads	93,700	2,752
Orange Roughy	Australia	Heads	13,440	394
Blue Mackerel	New Zealand	Tails	12,000	352
Salmon	Western Australia	Heads	11,420	335
Pork Fat	Western Australia		7,500	220
Silver Warehou	New Zealand	Heads	5,020	147
Blue Mackerel	New Zealand	Heads	40	1
TOTAL				73,308

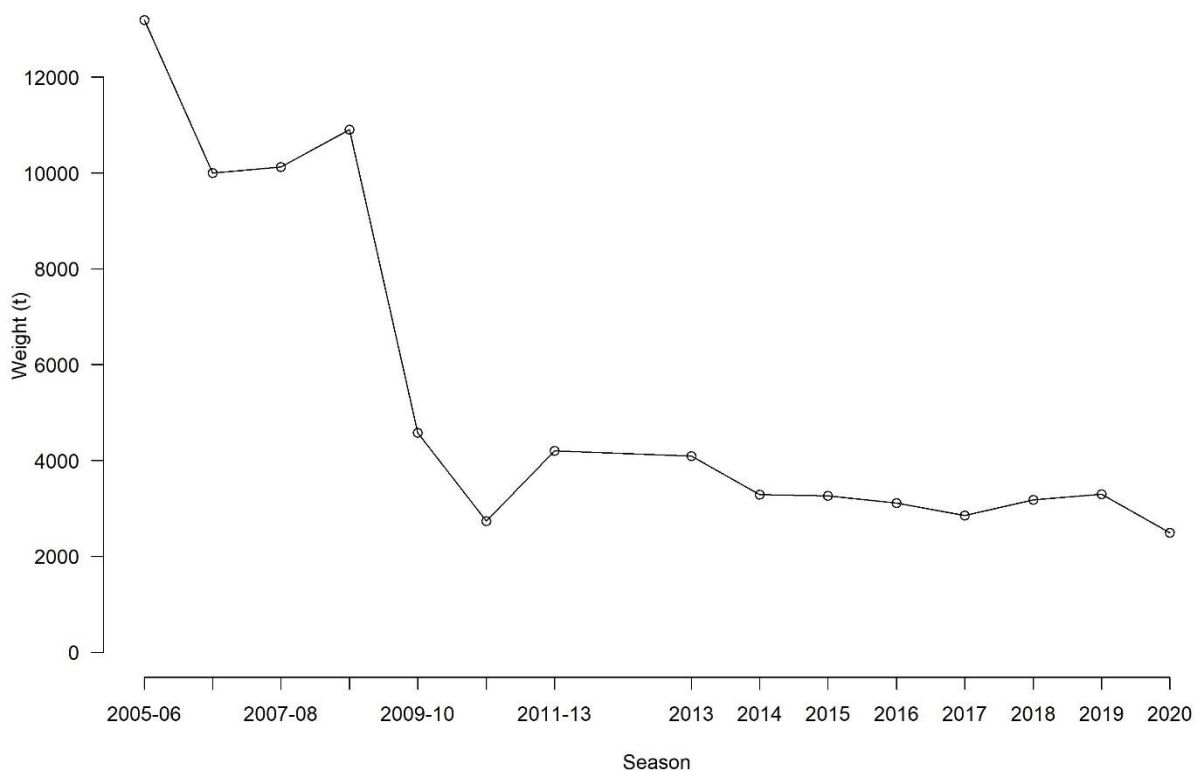

Figure 4-23 Total seasonal bait usage by the WCRLMF.

4.4 Recreational Fishery

Southern rock lobster is the only component of the Offshore Crustacean Resource which is accessed by the recreational fishers on the south coast of WA, with no catches of other offshore crustacean species (i.e., crystal crab, champagne crab, giant crab) reported in surveys of boat-based fishing from 2011/12 to 2020/21 (Ryan *et al.* 2013, 2015, 2017, 2019, 2022).

Annual phone-recall surveys of rock lobster licence holders specified to species level commenced in 2018/19. These surveys reported retained catches of southern rock lobster in all years. In 2021/22, an estimated 10,333 (95%CI 6,785 – 13,880) southern rock lobster were retained by recreational fishers, which is similar to the 15,639 (95%CI 57 – 31,220) retained in 2018/19, but lower than the peak of 44,954 (95%CI 13,019 – 76,889) in 2020/21 (Smallwood *et al.* 2021, 2022). Note that these estimates have not been adjusted to account for biases in survey methods, and the relative standard errors exceed 40% in some years, so values should be viewed with caution. Southern rock lobster are typically captured recreationally by either potting or diving. Diving is generally the most frequently used method to capture southern rock lobster, although this is not consistent between years (Smallwood *et al.* 2021, 2022).

Information on charter fishing catch and effort have been routinely collected since 2001, when a licensing framework and compulsory logbook system was implemented. Catches of southern rock lobster from charter fishers from 2018/19 – 2021/22 cannot be reported due to confidentiality (i.e., <3 operators reporting catches in each year) (Smallwood *et al.* 2021, 2022).

4.5 Customary fishing

Customary fishing is defined as fishing by an Aboriginal person for personal, domestic, ceremonial, educational or non-commercial communal needs. Customary fishing respects customary law and tradition, which includes fishing only where the person has a connection or permission from traditional owners of that area. Customary fishers are not required to hold a recreational fishing licence, however fishing rules that protect fish stocks and marine habitat still apply. These rules are the subject of review to ensure they best reflect the rights and responsibilities of traditional owners to access and look after aquatic resources, at the same time as addressing the statutory responsibilities of government to manage aquatic resources for future generations.

Given that the Offshore Crustacean Resource is generally limited to deep oceanic waters, customary fishing impacts on this Resource are limited to southern rock lobster in inshore areas along the south coast of WA.

4.6 Compliance

Operational Compliance Plans (OCP) guide the enforcement of management arrangements for each sector which accesses the Resource. OCPs are informed and underpinned by a compliance risk assessment and are reviewed every 1-2 years. OCPs have the following objectives:

- to provide clear direction and guidance to officers regarding compliance activities that are required to support effective management of the fisheries;
- to provide a mechanism that aids the identification of future and current priorities;
- to encourage voluntary compliance through education, awareness and consultation activities; and
- to review compliance strategies and their effective implementation.

Compliance strategies and activities that are used to protect the Resource include:

- land and sea patrols;
- catch validation against managed fishery licences for the WCDSCMF, WCRLMF and SCCMF, and recreational rock lobster fishing licences for the recreational sector;
- inspections at wholesale and retail outlets, and processing facilities;
- inspections of fishing vessels in port and at-sea;
- entitlement monitoring of the WCDSCMF, WCRLMF and SCCMF; and
- aerial surveillance.

5.0 Ecological Impacts

5.1 Retained Species

5.1.1 *Crystal Crab*



Figure 5-1 The crystal crab (*Chaceon albus*). Illustration © R. Swainston (www.anima.net.au).

Crystal crab (*Chaceon albus*) (Figure 5-1) is a large (maximum size >180 mm CW) Geryoniidae crab that is endemic to WA and distributed from North-West Cape to Esperance (Figure 5-2). It is found from 300 to 1,450 m depths in sand, mud or broken shell habitats. The species was originally thought to be the Pacific congener, *Chaceon bicolor*, until described as a new species (Davie *et al.* 2007).

Tagging studies indicate crystal crabs are slow-growing and long-lived with a likely maximum age of 25 to 30 years. Preliminary studies indicate that maturity in males is attained at 12 years and legal size at 14 years. There is little evidence of seasonality in the crystal crab reproductive cycle, and spawning occurs year-round (Smith *et al.* 2004b; Melville-Smith *et al.* 2007).

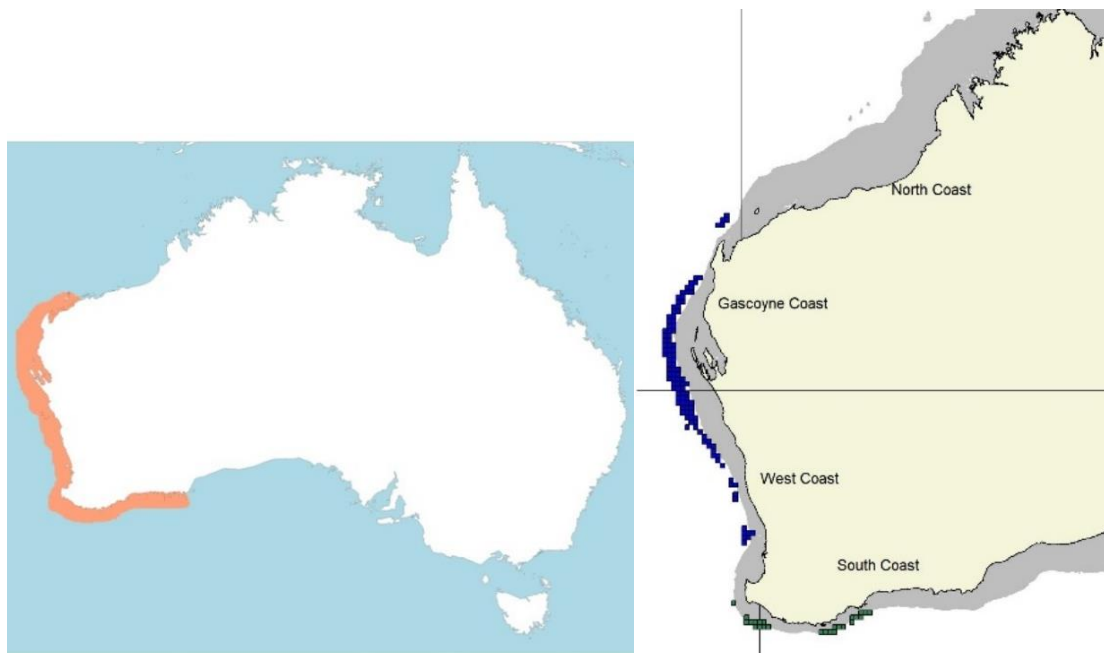

Figure 5-2 Species distribution (left) and the location of catch (right; 10x10 nm blocks) of crystal crab for the WCDSCMF (blue; 2017-2021) and SCCMF (green; 2019/20-2021-22). Grey indicates waters <200 m deep.

There is no information on the stock structure of crystal crabs on the west or south coasts of WA. Preliminary information suggests the movement of crystal crabs is limited (<50 km), although this is currently being re-examined. There is no information on the larval duration of crystal crabs. A congener (*C. quinquegens* formerly *Geryon quinquegens*) progressed from a stage one zoea to a juvenile crab in 39 days (Perkins 1973). While this was at warmer temperatures than occurs on the fishing grounds off WA, it does suggest a short larval duration, which implies limited dispersal during the larval stage. As most of the west coast and south coast catches come from relatively small geographic areas (Figure 5-2), the population on each coast is considered a single unit for management purposes. A FRDC funded project is currently underway to assess the genetic stock structure of crystal crabs on both the west and south coasts of WA.

Crystal crab is the primary target species of the WCDSCMF (Figure 5-3). In 2021, the WCDSCMF retained 139,939 kg of crystal crab, which represented 98% of the total catch of this species, with the remainder (2,736 kg) taken by the SCCMF.

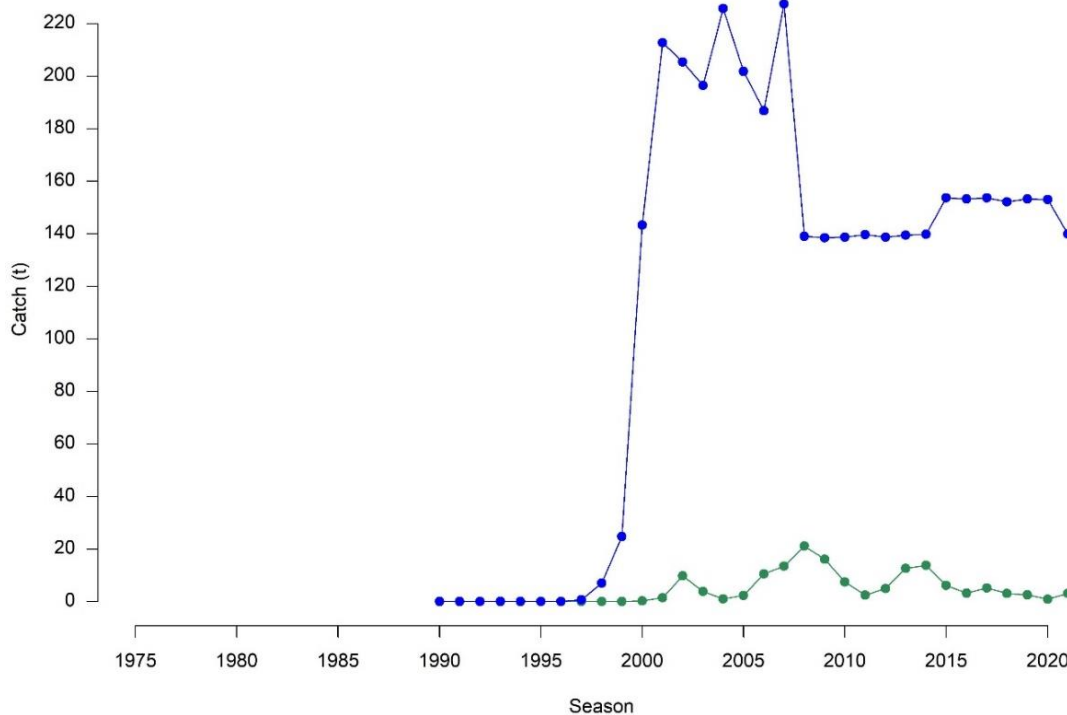

Figure 5-3 Seasonal (year indicates first year of a SCCMF season [financial year]) catch of crystal crab by the WCDSCMF (blue) and SCCMF (green).

In 2021, WCDSCMF landings representing 99.9% of the 140 t voluntary TACC. There was a formal reduction in the TACC for the 2022 season to 123.2 t due to sustainability concerns. In 2021, a weight-of-evidence assessment was conducted by the Department for the west coast crystal crab stock. Multiple lines of evidence including catch, catch distribution, effort, size composition, catch rates (including a fishery-independent index) and a biomass dynamics model indicated that the stock was a SEVERE risk. Preliminary data from the 2022 season indicated an improvement in the stock status and hence the 123.2 t TACC was recommended to remain for the 2023 season. A new integrated model is being developed for crystal crabs and adjustments to the harvest strategy are also being considered to reduce any localised depletion.

Crystal crab is also assessed in Zone 2 of the SCCMF (Figure 4-16). A biomass dynamics model indicated that the stock had recovered and was currently above the provisional threshold level. Maintenance of the 6 t quota for crystal crab in this zone would see the stock remain above the threshold level and being harvested at the provisional target level (Maximum Sustainable Yield; $MSY_{0.8}$), resulting in the stock being assessed as MEDIUM risk.

As part of an ERA for the Western Rock Lobster Resource, crystal crab capture in Zone 1 of the SCCMF was assessed as MEDIUM risk (Stoklosa 2022).

5.1.2 Champagne Crab



Figure 5-4 The champagne crab (*Hypothalassia acerba*). Illustration © R. Swainston (www.anima.net.au).

Champagne crab (*Hypothalassia acerba*) (Figure 5-4) is a large (~140mm CL, 2kg) decapod crustacean occurring in deep sea waters off the WA coastline, from approximately Kalbarri on the west coast, to Eucla on the south coast (Smith *et al.* 2004a) at depths of 90 to 310 m (Figure 5-5).

The age and growth of champagne crab has not been studied, however, like other deep sea species they are presumed to be relatively long lived and slow growing. Mean sizes of captured champagne crabs varies between the sexes (larger males) and time of year captured. Peak catch rates occur at depths of 200 m on the west coast of WA, compared to 145 m on the south coast. This difference may be due to temperature between the two regions, with 16.1–17.1 °C being the preferred range for champagne crab (Smith *et al.* 2004a).

Little is known about the movements of champagne crabs. Smith *et al.* (2004a) tagged 1,622 champagne crabs, of which 28 were recaptured, mostly within 50 km of their release. A small number demonstrated most substantial along-shelf movements (~200 km) in both a northwest and southwest direction.

There is limited information on the stock structure of champagne crab. Populations on the west and south coast differ in their reproductive characteristics, suggesting some degree of separation (Smith *et al.* 2004a). A FRDC-funded project is currently underway to assess the genetic stock structure of champagne crabs on both the west and south coasts of WA. Currently, the population on each coast is considered a single unit for management purposes.

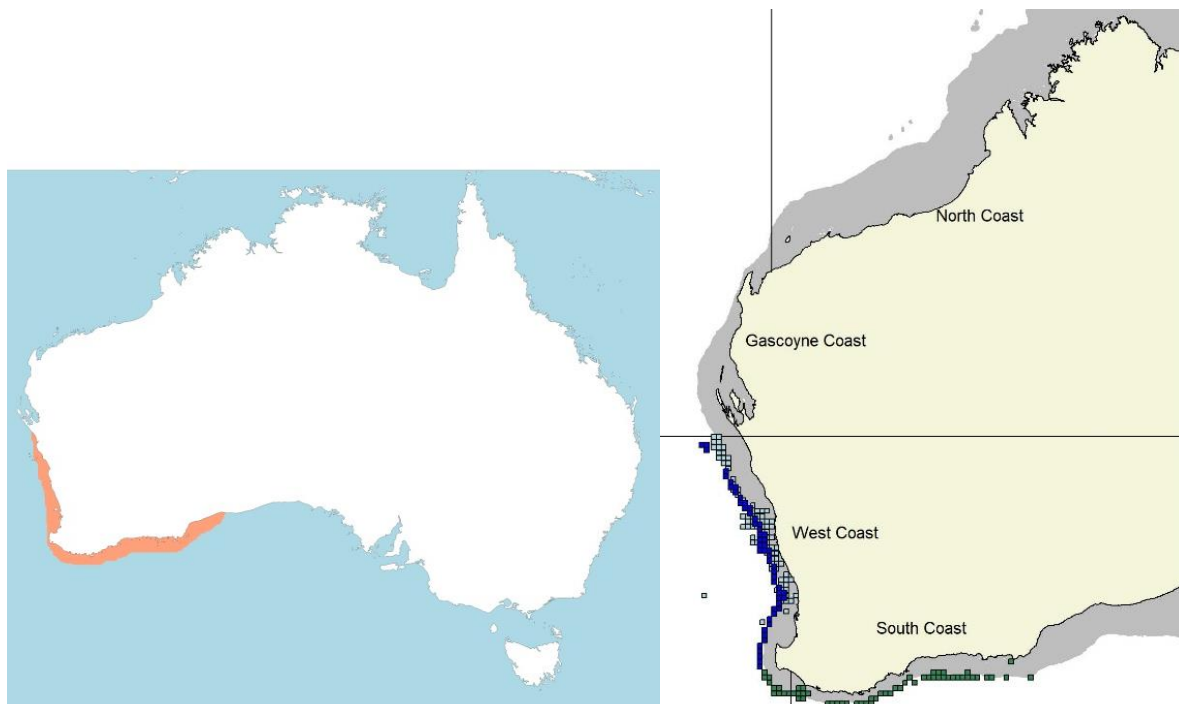

Figure 5-5 Distribution (left) and the location of catch (right; 10x10 nm blocks) of champagne crab for the WCDSCMF (blue; 2017-2021), WCRLMF (light blue; 2017-2021) and SCCMF (green; 2019/20-2021-22). Grey indicates waters <200 m deep.

Champagne crab was initially harvested off the west and south coast relatively evenly, though catches from the WCDSCMF declined in the early 2000s markedly while it was more gradual for the SCCMF (Figure 5-6). Catches from the WCRLMF has been consistent, but at a relatively low level. In the 2021 season, 14.0 t of west coast champagne crab was landed by the WCDSCMF, which was below their 20.02 t TACC. A further 1.5 t was taken by the WCRLMF.

Champagne crab is retained by the WCRLMF as a by-product of deep water fishing for migrating western rock lobster. WCRLMF fishers are permitted to land 12 deep sea crabs per day per boat, which has typically resulted in about 1 t of champagne crab being retained by this fishery per year. Almost all of the WCRLMF catch is landed during December – February, with >60% landed in January (Figure 5-7). The catch is almost exclusively in deep water, with over 50% of the catch reported between 80-90 fathoms (146-165 m) (Figure 5-7).

In 2021, a weight-of-evidence assessment was conducted by the Department for west coast champagne crabs. Multiple lines of evidence including catch, catch rates and a biomass dynamics model indicated that the stock was a MEDIUM risk.

In 2021, before the introduction of the ITQ system, south coast champagne crab was assessed by the Department using catch MSY estimates in Zone 2 of the SCCMF. This stock has recovered from the impact of higher catch levels in the late 1990s and early 2000s, with the current stock level estimated to be just below the provisional threshold level. As a result, the current risk score is HIGH. Maintenance of the current 5 t TACC under the ITQ system in this zone is expected to allow the stock to continue to improve, moving above the provisional threshold in the next couple of years.

As part of an ERA for the Western Rock Lobster Resource, champagne crab captures in the WCRLMF and in Zone 1 of the SCCMF were both assessed as LOW risk (Stoklosa 2022).

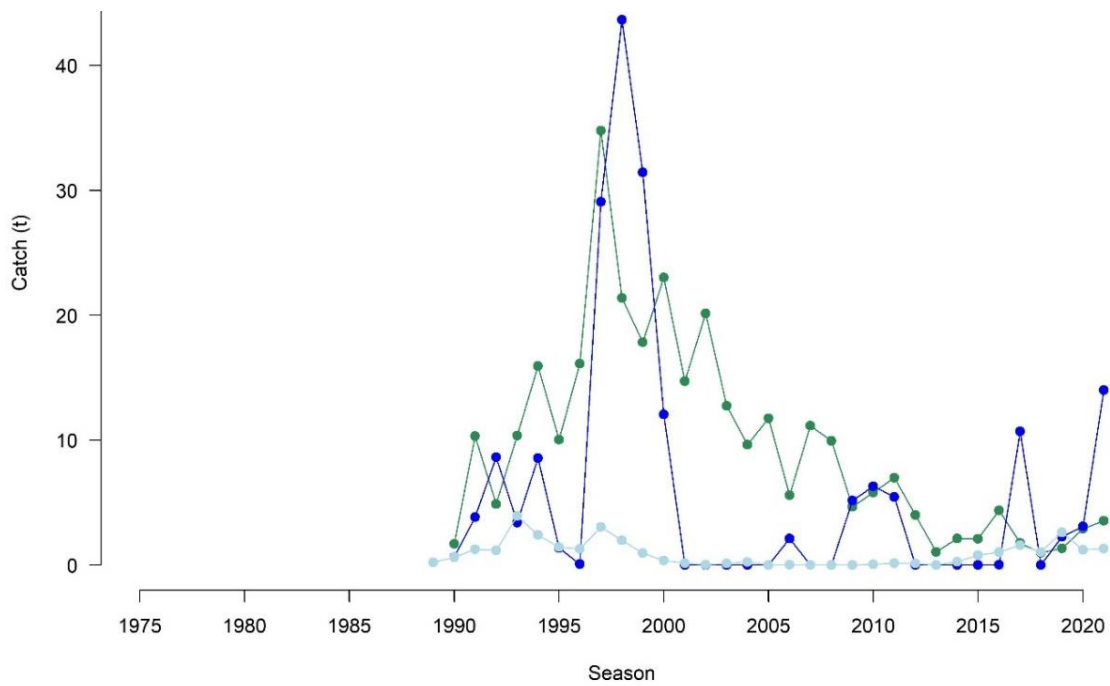

Figure 5-6 Seasonal catch of champagne crab by the WCSDCMF (blue), WCRLMF (light blue) and SCCMF (green). SCCMF season refers to the first year of a financial year.

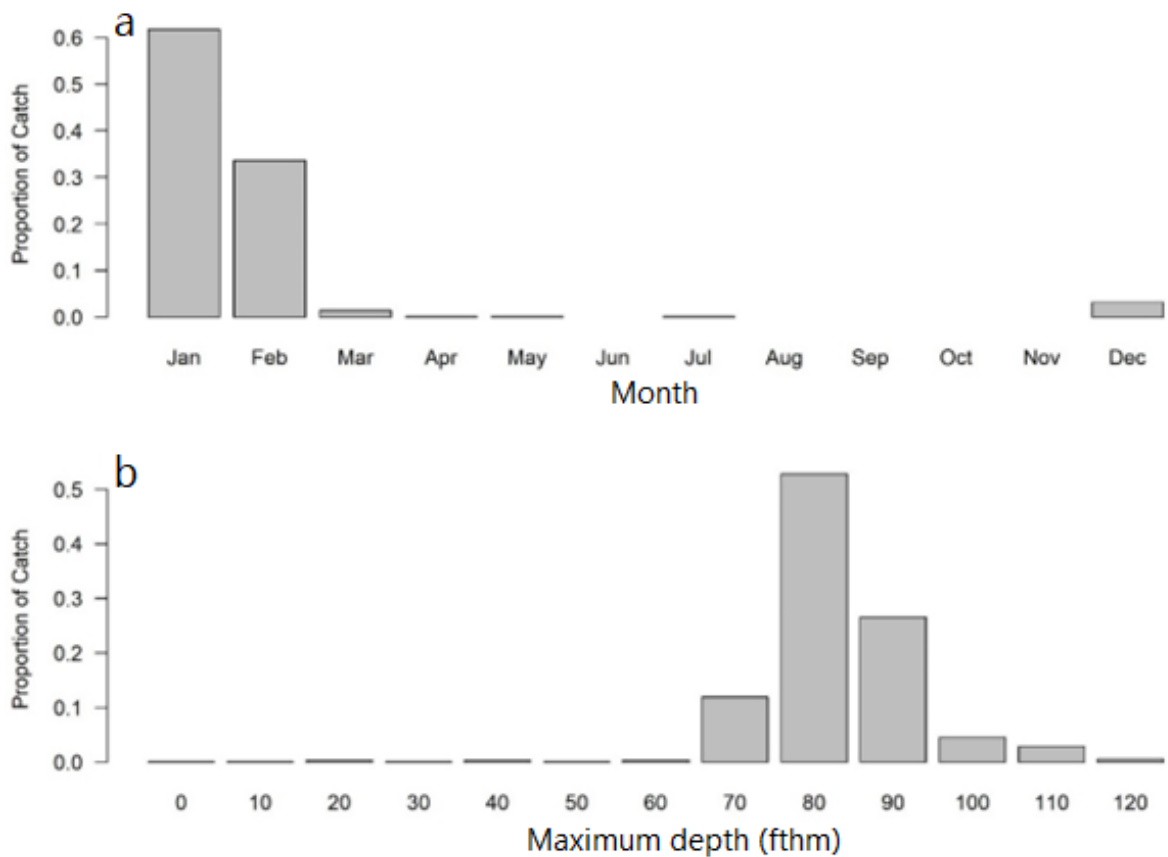

Figure 5-7 Proportion of annual catch of champagne crab landed by the WCRLMF by a) month and b) maximum depth (fathom).

5.1.3 Giant Crab



Figure 5-8 Giant crab (*Pseudocarcinus gigas*). Illustration © R. Swainston (www.anima.net.au)

The giant crab (*Pseudocarcinus gigas*) (Figure 5-8) is a large (up to 17.6 kg) decapod crustacean of the family Menippidae. It occurs on the continental shelf and shelf break across southern Australia from Perth Canyon, WA, to the central coast of New South Wales, mostly at depths of 120 to 370 m (Gardner 1998; Levings *et al.* 2001).

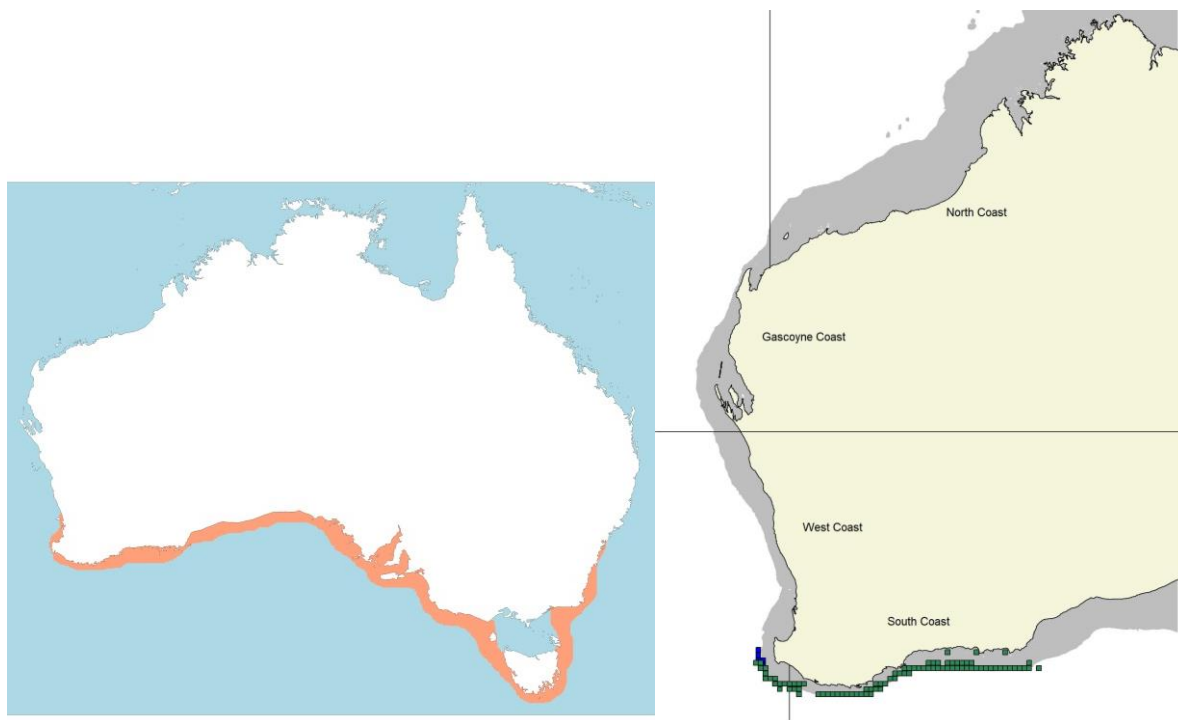

Figure 5-9 Distribution (left) and the location of catch (right; 10x10 nm blocks) of giant crab for the WCDSCMF (blue; 2017-2021) and SCCMF (green; 2019/20-2021-22). Grey indicates waters <200 m deep.

Individuals inhabit the steep terrain of the continental shelf, where they move upwards into warmer waters to access the more abundant benthic food resources and move into deeper waters to moult and to spawn. Males are captured from a wider depth range than females, with the majority of individuals captured at depths less than 120 m being male (Levings *et al.* 2001).

Giant crabs have a larval duration of approximate 50 days. Larvae are released at the shelf edge which is an area of high current flow that facilitates larval dispersal (Gardner 1998; Gardner and Quintana 1998; Williams *et al.* 2009).

Giant crabs are long-lived and slow growing. Growth parameters indicate a maximum age of ~25 years and maximum size of 460 mm CL. In South Australia females moult during winter (June and July), while males moult in summer (November and December) (McGarvey *et al.* 2002). Based on tag-recapture data, males were found to grow faster and moult more frequently than females; above 150 mm CL male intermoult duration was around four and half years compared to seven for females. In juvenile males and females (80–120 mm CL), the intermoult duration was three to four years. Radiometric ageing of giant crabs indicated a moult duration of nine years at larger sizes, generally consistent with the finding of slow growth and high longevity inferred from tagging studies (Gardner and Williams 2002).

Although giant crab is thought to comprise a single genetic stock throughout its geographic range, its status is currently assessed nationally at a jurisdictional (state) level. Length-based modelling indicates that the Tasmanian giant crab fishery is depleted and likely recruitment impaired (Hartmann *et al.* 2021). By contrast, the Victorian and South Australian assessments of giant crabs are assessed through catch rates to inform jurisdictional Total Allowable Catches (TACs). Victoria’s TAC was reduced from 25 t in 2011 to 10.5 t in 2014 where it has remained since. However, there continues to be a decline in the catch rates although they are still above the limit reference point. Catches in South Australia have remained relatively stable between 15 and 20 t since 2010 and catch rates remain above their trigger level for TAC reductions. In WA, catches have remained between 6-14 t since 2010 and are assessed across a wide geographic area (Fremantle – Esperance), indicating that the current level of fishing is unlikely to cause recruitment impairment.

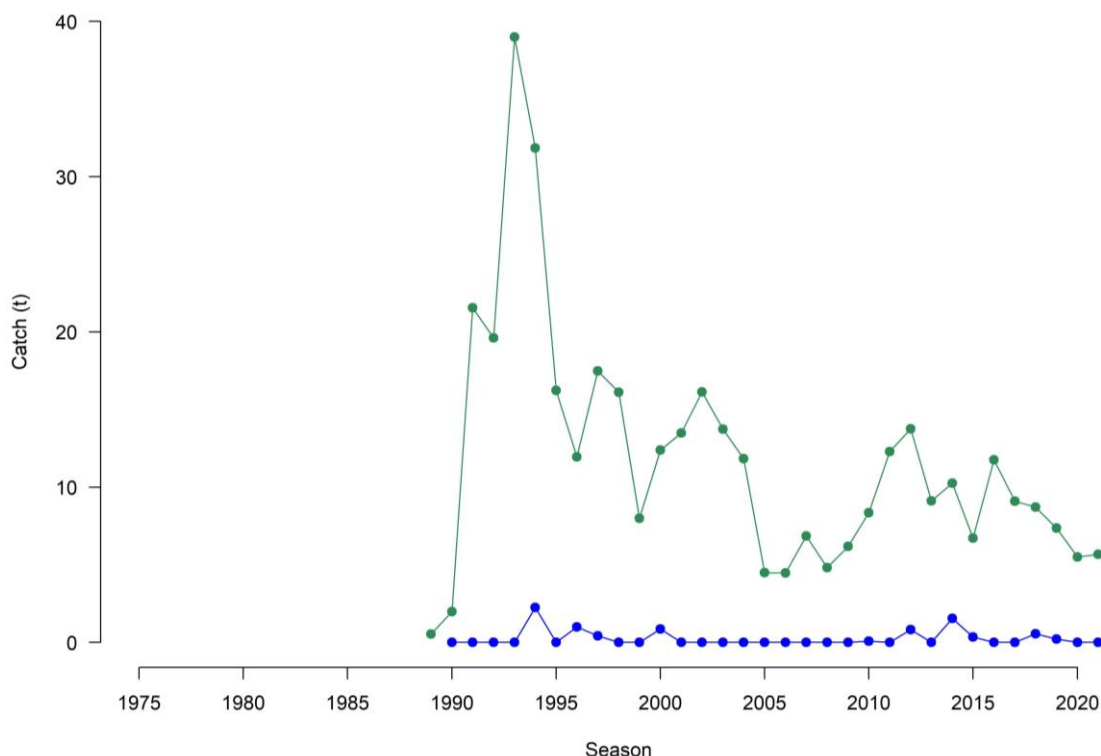

Figure 5-10 Seasonal catch of giant crab by the WSCDMF (blue) and SCCMF (green). SCCMF season refers to the first year of a financial year.

In WA, giant crab is harvested almost exclusively by the SCCMF, with minor retention of catch by the WCDSCMF (Figure 5-10). In 2021 the SCCMF retained 4,559 kg of giant crab, with 10 kg retained by the WCDSCMF. Giant crab catches by the SCCMF are assessed through catch MSY estimates in Zones 2 and 3 (Figure 4-16). Both zones were assessed as a HIGH risk of stock depletion, with estimates of stocks being just below the provisional threshold levels. Based on their respective 2 t and 2.5 t TACCs, giant crabs in Zones 2 and 3 are projected to move above the provisional threshold level in the next couple of seasons.

As part of an ERA for the Western Rock Lobster Resource, giant crab catches in Zone 1 of the SCCMF were assessed as HIGH risk (Stoklosa 2022). However, on 1 July 2022, the SCCMF transitioned to an ITQ system which reduced the risk to MEDIUM, as noted under 'treated risk' in the ERA.

5.1.4 Southern Rock Lobster



Figure 5-11 Southern rock lobster, (*Jasus edwardsii*). Illustration © R. Swainston (www.anima.net.au)

The southern rock lobster (SRL) (Figure 5-11), *Jasus edwardsii* (Hutton 1875), is a decapod crustacean of the family Palinuridae. Southern rock lobsters inhabit a variety of reef habitats in continental shelf waters from 1 – 200 m³ and are distributed across southern Australia from Coffs Harbour (northern NSW) to Cape Naturaliste (WA), including around Tasmania, with a few records in WA as far north as Dongara (Figure 5-12). They also occur around New Zealand. SRL comprise a single genetic stock across southern Australia (Ovenden *et al.* 1992).

SRL attain a maximum age of 20 years and maximum size of 230 mm CL. Growth rates vary substantially between locations due to environmental factors such as depth and population density (McGarvey *et al.* 1999; Punt *et al.* 2006). Males have a higher moult frequency and grow about 1.4 times faster than females (Linnane *et al.* 2011a). Fecundity of female SLR ranges from 100,000 to 1,000,000 eggs, depending on the age and size of the individual (Hobday and Ryan 1997). Eggs are attached to the pleopods, where they are carried for 4-6 months.

³ <https://www.dpi.nsw.gov.au/fishing/fish-species/species-list/southern-rock-lobster> (accessed 8 Nov 2022)

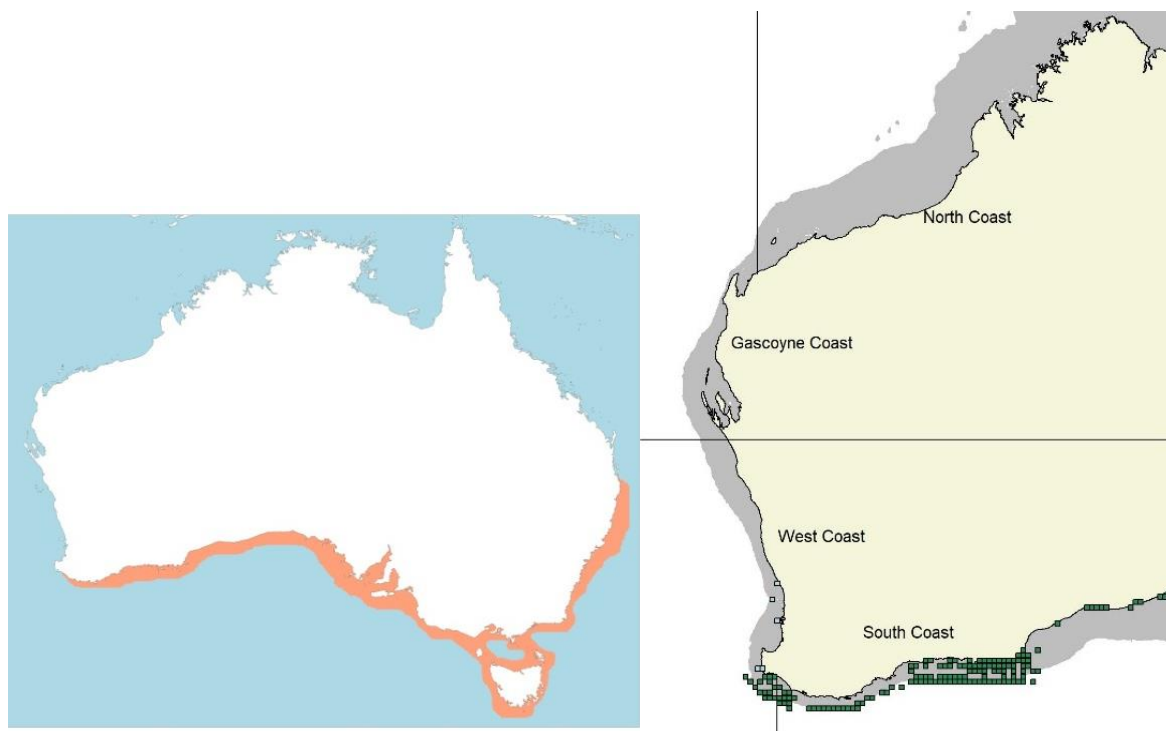

Figure 5-12 Distribution (left) and the location of catch (right; 10x10 nm blocks) of southern rock lobster the WCRLMF (light blue; 2017-2021) and SCCMF (green; 2019/20-2021-22). Grey indicates waters <200 m deep.

SRL has an offshore larval phase of up to 24 months, during which time larvae are dispersed and mixed widely by currents resulting in the observed genetic homogeneity of the stock. The Southern Zone of the South Australian Rock Lobster Fishery (SARLF) has the highest level of egg production off southern Australia, and based on biological and hydrodynamic modelling, this area is likely to be a major source of pueruli (Bruce *et al.* 2007). The net eastward transport of larvae across southern Australia means that SRL off the WA south coast may contribute to recruitment in other regions, however most of the recruitment to the WA south coast probably originates from the Great Australian Bight.

The status of the SRL genetic stock is assessed nationally using an integrated model. The most recent assessment in 2020 indicated that the stock is sustainable (Linnane *et al.* 2021).

Although regional populations of SRL are genetically similar, differing environmental conditions across southern Australia mean they vary substantially in life history characteristics. As such, WA populations are considered as a spatially discrete units for management purposes.

In WA, SRL is harvested almost exclusively by the SCCMF with very minor incidental catch in the WCRLMF (Figure 5-13). The SCCMF retained 6,207 kg of southern rock lobster in 2021. Assessments are undertaken for SRL in Zones 3 and 4 of the SCCMF (Figure 4-16). The most recent assessments indicated that the risk of SRL stock depletion is HIGH and MEDIUM for Zone 3 and Zone 4, respectively. The stock level in Zone 4 is above the nominal threshold level, while the Zone 3 stock is recovering towards the threshold level. Catch limits have been formally implemented in both zones under the ITQ system for the fishery to ensure ongoing sustainability of SRL in the SCCMF. Both zones are assessed as sustainable on this basis.

As part of an ERA for the Western Rock Lobster Resource, SRL capture in Zone 1 of the SCCMF and in the WCRLMF were both assessed as NEGLIGIBLE risk (Stoklosa 2022).

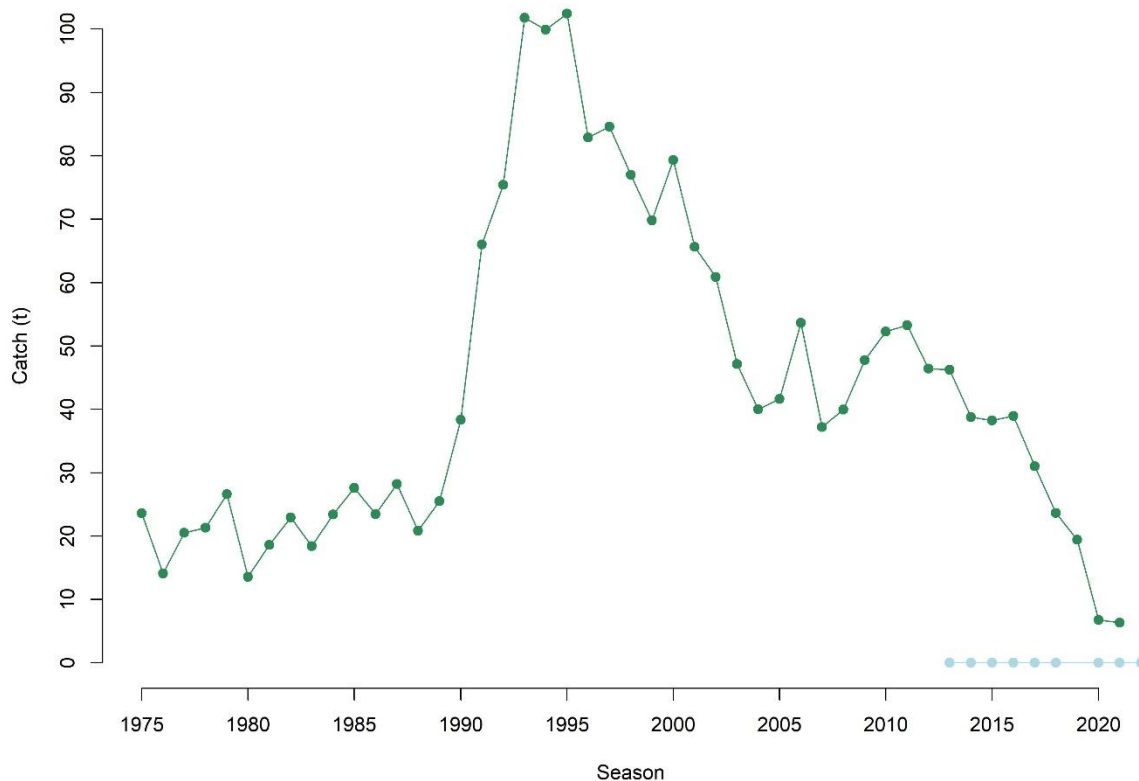

Figure 5-13 Seasonal catch of southern rock lobster in the WCRLMF (light blue) and SCCMF (green). SCCMF season refers to the first year of a financial year.

5.1.5 Other Retained Species

A number of other species are captured and retained by fishers accessing the Offshore Crustacean Resource. Some may be retained for sale or personal consumption. They are, however, not actively targeted by fishers, but are incidental catch and often referred to as ‘by-product’ species.

The subset of by-product species that are captured by the WCRLMF while targeting offshore crustaceans can be estimated from the timing and depth of capture. Harvesting of offshore crustaceans (mainly champagne crab) by the WCRLMF predominantly occurs from December to February in deeper waters (≥ 70 fathoms/ ≥ 128 m) (Figure 5-7). For example, in 2021/22 financial year, 95% of champagne crab caught by the WCRLMF were from this time/depth range (Table 5-1).

Similarly, a range of other by-product species are retained by SCCMF fishers. Depending on the species some may be retained for commercial sale, or personal use, whilst the take of other species such as sharks or hermit crabs is prohibited. Leatherjackets are also retained for bait in fishing operations (Table 5-2).

The WCDSMF does not retain any non-target species.

Table 5-1 All species retained by the WCRLMF during the 2021/22 financial year when potentially accessing the Offshore Crustacean Resource (Dec-Feb in deep waters \geq 70 fathoms / 128 m), with their total Dec-Feb catch in kilograms and as a percentage of total WCRLMF catch.

Species	Total WCRLMF catch (kg)	Catch in deep water (Dec-Feb)	
		kg	% of total WCRLMF catch
Champagne crab	928	878	95
Leatherjacket	114	102	89
Pink snapper	789.1	254.5	32
West Australian dhufish	42	8	19
Breaksea cod	86	6	7
Baldchin groper	2337.7	13	1
Cuttlefish	150.9	0	0
Flatheads	1.5	0	0
Octopus	8928.7	24.9	0
Redthroat emperor	199	0	0
Rockcods	20	0	0
Scorpionfishes	7	0	0
Southern Rock Lobster	21	0	0
Spangled emperor	3	0	0
Wobbegong shark	27.5	0	0
Wrasse	2	0	0

Table 5-2 Number of retained non-target species by season, reported by fishers in the SCCMF.

Group	Species	2019/20	2020/21	2021/22
Crustacean	Cape spear lobster			20
Teleost	Leatherjacket	4401	1557	80
	Breaksea cod	51		19
	Harlequin	10	1	25
	Knifejaw	2	3	
	Morwong		2	
	Ling		1	

5.1.5.1 Invertebrates

“Cape spear lobsters” have been reported as retained by fishers in the SCCMF. These are believed to be the cape jagged lobster, *Projasus parkeri*, a deep sea species (370-841 m) known from waters of the southern hemisphere, from south-west Africa to St Paul Island, through to New Zealand (Holthuis 1991). Twenty individuals were reported retained by fishers from 2019/20 to 2021/22 (Table 5-2) with only one individual discarded (Table 5-7). *P. parkeri* is classified as “Least Concern” assessed under the IUCN Red List of Threatened Species and (MacDiarmid *et al.* 2011).

Approximately 50 kg of octopus were retained by WCDSCMF in 2021 while accessing the Resource (Table 5-1). Retention of octopus by the WCRLMF was assessed as LOW risk during the ERA for the Western Rock Lobster Resource (Stoklosa 2022).

5.1.5.2 Leatherjackets

Leatherjackets (combined records of “Ocean Leatherjackets”, “Horseshoe Leatherjackets” and “Leatherjackets”) are the main teleost retained by fishers in the SCCMF (Table 5-2), which reported 4,401 retained individuals in 2019/20 (approximately 3.5 t, assuming 0.8 kg per fish). Lesser quantities of leatherjackets were retained in 2020/21 and 2021/22 reflecting substantially lower fishing effort in those years (Figure 4-18). Small quantities are also discarded by the SCCMF (Table 5-7). Leatherjackets caught in deep sea traps suffer high rates of barotrauma-related injuries when brought to the surface and so discarded individuals are assumed to suffer to high mortality (Miller and Stewart 2009). Minor quantities of leatherjackets also retained by the WCRLMF while accessing the Offshore Crustacean Resource (Table 5-1).

These catches comprise Horseshoe Leatherjacket (*Meuschenia hippocrepis*) and Ocean Leatherjacket (*Nelusetta ayraudi*) as well as other members of the Monacanthidae.

Meuschenia hippocrepis is endemic to southern and western Australia, from Wilsons Promontory, Victoria, to about Shark Bay, WA, including northern Tasmania, and is relatively abundant across this range (Bray 2020a). It inhabits rocky reefs with kelp and other macroalgae in embayments and estuaries and on offshore reefs to a depth of 120 m. Individuals can attain a maximum length of 60 cm. Age, growth and maturation are unknown for this species, but the congener *M. scaber* has rapid initial growth, reaching maturity in 1-2 years, and moderate longevity (at least 10 y for males and 17 y for females) (Visconti *et al.* 2018a). *M. scaber* has demersal eggs and planktonic larvae (Visconti *et al.* 2018b).

Nelusetta ayraudi ranges across southern Australia from Exmouth, WA to Moreton Bay, Qld, and is relatively abundant across this range (Bray 2020b). It has a depth range of 0-360 m, with older fish tending to occur in deeper (>100m) waters (Lindholm 1984). *N. ayraudi* is relatively fast growing and reaches maturity at about age 2.5 y and length of 350 mm (Miller and Stewart 2013). Individuals can attain a maximum length of 100 cm and age of at least 9 y (<https://www.fishbase.se/summary/14549> accessed Nov 2022). Unlike most monacanthids, it is a broadcast spawner with pelagic eggs and larvae that are dispersed widely by alongshore currents (Miller and Stewart 2013).

The biological traits of *M. hippocrepis* and *N. ayraudi* (fast growth, early maturation, large population and species range, a planktonic stage with potentially wide dispersal) make these species moderately resilient to exploitation.

In 2021, a total retained catch of ~16 t of leatherjackets (all species combined) was reported by other commercial fishers in the SCB.

5.1.5.3 Other Teleosts

Several other teleost species were retained in minor quantities by fishers in the WCRLMF (Table 5-1) and SCCMF (Table 5-2).

A total of 70 breaksea cod (*Epinephelides armatus*), 36 harlequin fish (*Othos dentex*), five knifejaw (*Oplegnathus woodwardia*), two (blue) morwong (*Nemadactylus valenciennesi*) and a single (pink) ling (*Genypterus blacodes*) were retained over three seasons by SCCMF fishers. Of these species, blue morwong on the south coast is the only stock to be recently

assessed. It is a key species in the South Coast Demersal Scalefish Resource and is currently at MODERATE risk (Norriss *et al.* 2021).

Breaksea cod and harlequin fish are both endemic to marine waters off southwestern Australia at a depth range of 0-100 m and 0-30 m, respectively (Bray 2020c, 2020d). They are relatively slow growing, long-lived and large-bodied, making them inherently vulnerable to exploitation. Breaksea cod attain a maximum total length of 860 mm and have a potential longevity at least 42 years, while harlequin fish attain 560 mm and about 20 years (Moore *et al.* 2007; French *et al.* 2014). In 2020/21, ~23 t of breaksea cod and <5 t of harlequin fish was caught in WA, mostly by recreational fishers (Newman *et al.* in prep).

While accessing the Resource in 2021/22, WCRLMF fishers were estimated to retain 254 kg of snapper (*Chrysophrys auratus*), 13 kg of baldchin grouper (*Choerodon rubescens*), 6 kg of breaksea cod and 8 kg WA dhufish (*Glaucosoma hebraicum*) (Table 5-1). Baldchin grouper harvested by the WCRLMF was assessed as a HIGH risk during the Western Rock Lobster Resource ERA (Stoklosa 2022), however the retention of baldchin grouper while accessing the Offshore Crustacean Resource accounts for <1% of the total take on which this high risk rating was based (Table 5-1). Snapper was assessed as a LOW risk during the Western Rock Lobster Resource ERA (Stoklosa 2022). Thirty two percent (32%) of the total take of snapper by the WCRLMF occurs when accessing the Offshore Crustacean Resource (Table 5-1).

5.2 Bycatch species

5.2.1 West Coast Deep Sea Crustacean Managed Fishery

Bycatch (i.e., discarded species) in the WCDSCMF is recorded by fishers on a trip-by-trip basis on CDRs (Table 5-3). These indicate very low levels of reported bycatch, particularly given the considerable effort which occurs in the fishery. These bycatch reports have been validated using an on-board camera system. They also confirmed a very low level of bycatch by the WCDSCMF (Table 5-4).

Table 5-3 WCDSCMF Effort levels and bycatch recorded on catch disposal records by season.

Season	Potlifts	Bycatch (comments on CDRs)
2017	98,370	Heaps of red devil crabs in deeper ends of lines; 1 spider crab
2018	81,192	8 red sponge crabs 350fm
2019	86,084	none
2020	113,219	none
2021	133,82	1 octopus

Table 5-4 Number of WCDSCMF potlifts and bycatch recorded by onboard camera monitoring by season.

Season	Potlifts	Bycatch (camera validation)
2017	2,068	none
2018	1,845	1 x spider; 1 x octopus
2019	1,011	none
2020	1,006	1 spider crab
2021	830	none

Records of bycatch species are also made during fishery-independent surveys (How *et al.* 2022a). In these surveys fishing occurs inside and outside the main fishing grounds for crystal crabs, and utilises standard commercial pots used in the WCDSCMF and modified pots (meshed pots with no escape gaps) for research purposes (Table 5-5). From the 7,294 pots sampled, there have been 327 bycatch individuals of any species recorded, with 263 coming from the 6,938 commercial pots.

Surveys at Carnarvon have sampled a broad range of depths. The majority of bycatch individuals (of any species) were captured outside of this depth range, with only 60 individuals retained in standard commercial pots (open pots) from between 350-700 m (Figure 5-14), with over half of these being octopus (Table 5-6).

Table 5-5 Number of pots deployed (by type) and the number of bycatch individuals (of any species) captured in each fishery-independent survey.

Survey	No. of Pots			No. of bycatch individuals
	Mesh (research)	Open (commercial)	Total	
Carnarvon 2017	30	1,153	1,183	32
Carnarvon 2018	53	1,033	1,086	238
Carnarvon 2019	75	958	1,033	20
Carnarvon 2020	51	1,120	1,171	11
Carnarvon 2021	43	904	947	17
Fremantle 2021	0	224	224	0
Kalbarri 2020	56	781	837	0
Kalbarri 2021	48	352	400	9
Kalbarri 2022	0	413	413	0

Table 5-6 Common name and total number of bycatch individuals captured in open pots deployed between 350–700 m depth off Carnarvon during fishery-independent surveys between 2017 and 2021.

Common Name	Number
Octopus	36
Mollusc	7
Brittlestar	4
Spider crab	2
Slipper lobster	2
Coral polyp	2
Lamprey	1
Prawn	1
Polychaete	1
Crustacean	1
Starfish	1
Spear lobster	1
Urchin	1

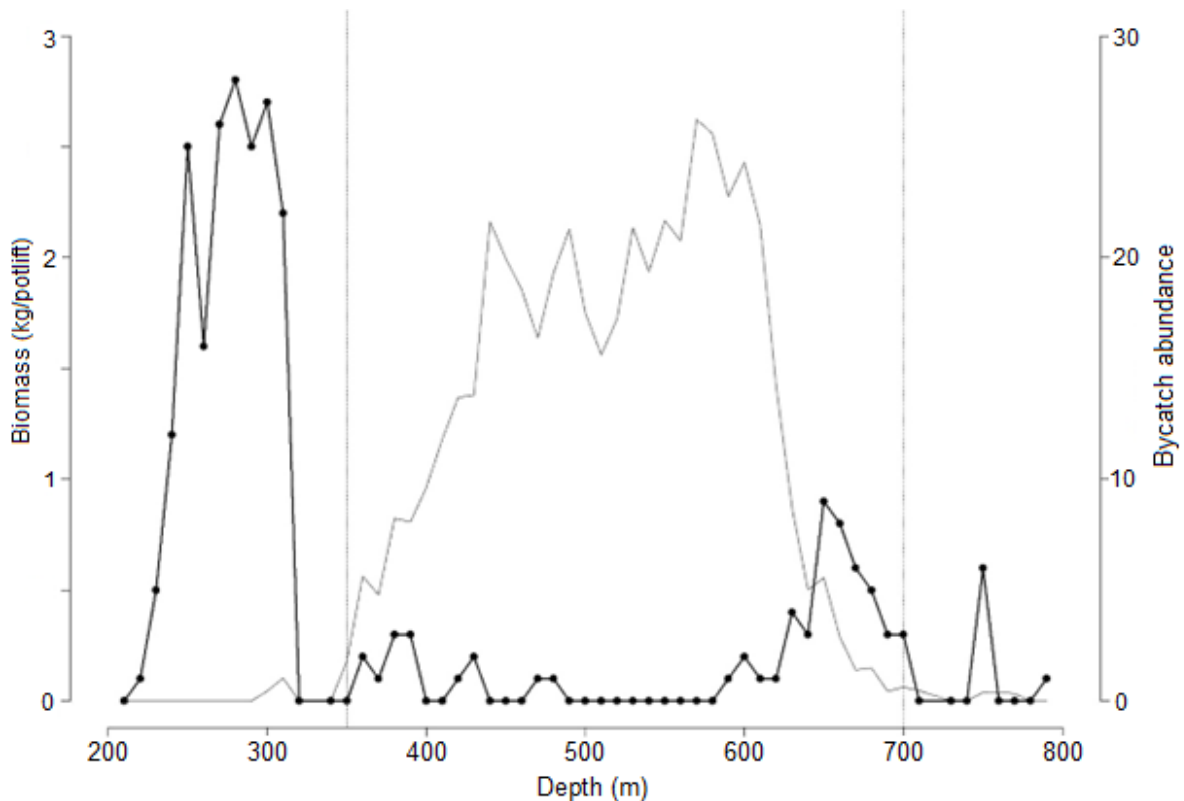

Figure 5-14 Abundance (n) of bycatch species (dark line) and biomass (kg/potlift) of crystal crabs by 10 m depth increments recorded during fishery-independent surveys off Carnarvon. Vertical dotted lines denote the main area of crystal crab abundance.

5.2.2 South Coast Crustacean Managed Fishery

Prior to the 2019/20 season, the statutory return of the SCCMF was a monthly catch and effort return. This did not necessitate the recording of species which were discarded or retained for non-commercial purposes. Since the 2019/20 season, fishers have been required to complete a trip return where all species (retained and discarded) and quantities are recorded. Leatherjackets (combined records of “Ocean Leatherjackets”, “Horseshoe Leatherjackets” and “Leatherjackets”) were the dominant bycatch species by number and were predominantly retained (Table 5-7). These were also among the most common species discarded (Table 5-7), along with Port Jackson sharks (*Heterodontus portusjacksoni*). All Port Jackson sharks are discarded by the SCCMF, with a total of 270 being reported over the past three seasons (Table 5-7).

5.2.2.1 Port Jackson shark

The Port Jackson shark is abundant and widespread across southern Australia from northern New South Wales (NSW) to the Houtman Abrolhos, WA. It inhabits rocky reefs and adjacent sandy and seagrass areas, to a maximum depths of 275 m. There are two major subpopulations of this species in Australia: western (WA, SA, Victoria) and eastern (NSW, Victoria and Tasmania) (Day *et al.* 2019).

Although not targeted, Port Jackson sharks are taken in various commercial fisheries across its distribution, sometimes in high numbers, and also occasionally by recreational anglers. They are discarded (often alive) as they are considered to be of poor eating quality. Port

Jackson sharks are very resilient to capture stress from gillnet, trawl, and longline gear (Frick *et al.* 2009; Frick *et al.* 2010a, 2010b; Braccini *et al.* 2012), suggesting that the species is likely to have high post-release survival rates from a range of fishing methods.

In WA, an estimated total of 10-15 t is discarded annually by commercial and recreational fishers (Watt *et al.* 2021). About half of these discards occur in the Temperate Demersal Gillnet and Demersal Longline Fisheries (TDGDLF). In 2021, the risk to the Port Jackson shark stock posed by TDGDLF annual discards of 4-7 t was assessed as NEGLIGIBLE (Watt *et al.* 2021).

The status of the Port Jackson shark across its range was assessed as “sustainable” in 2019 (Simpfendorfer *et al.* 2019). The IUCN Red List status for this species globally and in Australia is “Least Concern”.

Table 5-7 Number of bycatch species and fate (disc=discarded, unkn=unknown) by season, reported by fishers in the SCCMF.

Group	Species	2019/20		2020/21		2021/22	
		Disc.	Unkn.	Disc.	Unkn.	Disc.	Unkn.
Echinoderm	Starfish					12	
Cephalopod	Octopus	30				4	
Crustacean	Cape Spear Lobster					1	
	Slipper lobster			3			
	Velvet crabs					2	
	Racehorse crab					2	
	Spider crab					1	
	Spear lobster			1			
Teleost	Leatherjacket	86	3		3	37	
	Breaksea cod	21	2			57	
	Harlequin	7	1			9	
	Knifejaw	8				4	
	Morwong	1					
	Morey eel					2	
	Eel				1		
	Ling						
	Nannygai		1				
	Rockcod		1				
Conway Fish				1			
Elasmobranch	Port Jackson shark	167	3			100	
	Carpet Shark	16	2			9	
	7 Gill shark				2		
	Deepwater shark				1	1	
	Green eye shark				1	1	
	Spurdog shark				1		

5.2.3 West Coast Rock Lobster Managed Fishery

Commercial monitoring is undertaken by DPIRD staff on-board commercial WCRLMF vessels each month. Sampling provides biological data on the catch of western rock lobster but also provides information on bycatch species. For full details of the commercial monitoring program see de Lestang *et al.* (2016).

On-board commercial monitoring in 2021 sampled >8,000 potlifts over 142 trips and recorded a range of bycatch species (Table 5-8). Octopus were most common retained species recorded in all samples which aligns with their large overall catch in the WCRLMF (Table 5-1). The reduced spatial and temporal access of the Resource by the WCRLMF to Dec-Feb in deep water (≥ 70 fathoms; 128 m) saw a marked reduction in commercial monitoring in these depths. Only four trips sampling ~100 pots occurred in 2021 where they may have accessed the Resource, with no bycatch reported.

Table 5-8 Number of individuals recorded during commercial monitoring on WCRLMF vessels by species and fate (kept= retained, alive=discarded alive, dead=discarded dead) for the 2021 season.

Group	Species	Kept	Alive	Dead
Echinoderm	Sea Urchin	0	1	0
Cephalopod	Octopus	78	3	0
	Cuttlefish	0	1	0
Crustacean	Hermit crab	0	5	0
	Coral crab	0	2	0
	Crab	0	1	0
	Slipper lobster	0	1	0
Teleost	Blacktip rockcod	1	8	0
	Breaksea cod	1	5	0
	Fish	0	4	0
	Western king wrasse	0	3	0
	Eel	0	2	0
	Western wirrah	2	2	0
	Baldchin groper	7	1	1
	King wrasse	0	1	0
	Knife jaw	0	1	0
	Seahorse	0	1	0
	Western red scorpioncod	0	1	0
	Snapper	3	0	0
	Spangled emperor	1	0	0
Elasmobranch	Wobbegong	0	13	0
	Port Jackson	0	9	1

5.3 Endangered, Threatened and Protected (ETP) Species

In this ERA, an ETP species ‘interaction’ is defined as an incident when a listed species is injured/killed as part of the fishing operation or requires human intervention to be removed from fishing gear. This includes accidental capture in the fishing gear, entanglements, boat strikes, observed dropouts of dead/injured animals. It does not include observations, attendance or feeding behaviour, or provisioning (e.g., feeding birds).

In addition to these interactions, fishing can generate multiple forms of pollution (noise, light, plastic rubbish, oil spills, etc) that can potentially impact on ETP species (see Section 5.6).

All commercial fisheries in WA, including the WCDSMF, SCCMF and WCRLMF, are required to report any interaction with ETP species in their statutory fishing returns. The Department is responsible for reporting these interactions in the publicly available annual State of the Fisheries and Aquatic Resources reports [<https://www.fish.wa.gov.au/About-Us/Publications/Pages/State-of-the-Fisheries-report.aspx>]. Some ETP interactions, such as entangled whales may move gear away from the fishers’ operations, and hence are not observed and therefore unable to be reported by commercial fishers. Reported entanglements from all sources are collated and provided to government agencies (state and commonwealth) as well as industry bodies annually.

In the past 5 years (2017-2021), the WCRLMF recorded a total of 303 ETP species interactions, involving bottlenose dolphins (20 interactions), humpback whales (278), sharks (3), a leatherback turtle (1) and an unidentified whale (1) (Table 5-9). None of these interactions resulted in mortalities of ETP species. These 303 interactions were reported by 15 unique vessels.

Table 5-9 Protected species ‘interactions’ reported by season by the WCRLMF, WCDSMF and SCCMF. Note, many of these are observations that do not represent a physical interaction between the WCRLMF and ETP species (see text above).

Fishery	Common Name	Season				
		2017	2018	2019	2020	2021
WCRLMF	Bottlenose Dolphin				5	15
	Humpback Whale	46	25	22	79	106
	Sharks	2			1	
	Turtle, Leatherback	1				
	Whales	1				
WCDSMF	Humpback Whale				1	1
SCCMF	Humpback Whale		1			

While reported as ‘interactions’, the accompanying comments by fishers (where provided) indicated that most were ‘observations’. For example, the 15 reported bottlenose dolphin interactions in 2021 (Table 5-9) were accompanied by the following comment “*Playing alongside vessel. One baby!*”. Similarly, 20 humpback whales that reportedly interacted with one vessel in 2017 were accompanied by the comment “*They were jumping in the air and having so much fun. I’m sure they were practicing their cannonballs*”.

On the basis of accompanying comments, few of the reported ‘interactions’ were likely to have been deleterious physical interactions between the WCRLMF fleet and ETP species. During 2017-2021, there were five comments which indicated negative interactions with ETP species. One involved a “possible collision with whale” in 2017. The remaining four indicated

entanglements of humpback whales. All of these WCRLMF reports were validated by cross-referencing against independently reported entanglements in the entanglement database.

In the past 5 years (2017-2021), there was only one interaction with ETP species recorded by the WCDSCMF (Table 5-9). This was a reported mortality of a humpback whale which was also reported separately to the Department with detailed records as part of the entanglement database. There have been no reported entanglements by fishers in the last three seasons (2019/20 – 2021/22), though there has been independent reporting of an interactions with this fishery with a large cetacean in 2018 and 2015 (see below).

5.3.1 Cetaceans

All cetaceans are protected under the Commonwealth EPBC Act. Twenty five species of whales occur in waters off south-western Australia (CoA 2012). Three of these species (humpback, southern right and pygmy blue whales) are known to reside, forage or breed in, or migrate through, fishing areas and, on this basis are considered to have the potential to interact with the fishery. Also, these baleen whales have several characteristics that influence the risk of entanglement in fishing gear. All species are large (6-30 m total body length) and tend to roll upon encountering fishing gear which increases their entanglement. Baleen whales do not echo-locate and have limited ability to detect structures. Adverse environmental conditions (e.g. poor visibility due to high river flows or rough weather) may increase the likelihood of entanglement. A large mouth gape, baleen plates and rough body surfaces contribute to the likelihood of becoming entangled. Baleen whales spend time at the surface which generates the potential for boat strikes.

5.3.1.1 Humpback whale (*Megaptera novaeangliae*)

Due to their abundance in WA waters, humpback whales (*Megaptera novaeangliae*) are the whale species considered most likely to interact with the fisheries targeting the Resource.

WA hosts the largest population of humpback whales in the southern hemisphere. It is currently estimated to be significantly more than 30,000 individuals, which is regarded as fully recovered, and so is no longer listed as “Threatened” under the EPBC Act (DAWE 2022). It is listed as “Conservation Dependent” under the WA Biodiversity Conservation Act 2016 (BC Act).

Humpback whales migrate annually between their summer feeding grounds in Antarctica and their breeding grounds off the north-west Australian coast between May and October. They are seen on the WA south coast during March-November, with peak abundance during June-August. During the northern migration, humpbacks are coastally associated, remaining further offshore on their southern migration (How *et al.* 2021).

Of the fisheries accessing the Resource, the WCRLMF has had the greatest number of entanglements with whales, with 104 reported whale entanglements in commercial western rock lobster gear since 1990. All but two entanglements involved humpback whales. All This level of interaction with the WCRLMF was assessed in 2022 during an ERA undertaken for the Western Rock Lobster Resource and found to be a LOW risk to whale species (How *et al.* 2022b; Stoklosa 2022).

The WCRLMF only accesses the Resource during the summer (Dec-Feb; Figure 5-7) when humpback whales are not present on the Western Australian coast. Therefore, the likelihood of a whale entanglement while the WCRLMF is accessing the Resource is considered to be negligible.

In the WCDSCMF, there have been 3 reported entanglements since 1990, occurring in 2014, 2020 and 2021. One whale was disentangled in 2014, while a whale in 2020 evaded disentanglement. The entanglement in 2021 resulted in a mortality as it appears the whale swam into the gear as it was set, and subsequently drowned.

The likelihood of humpback whale entanglement in the WCDSCMF is considered very low, due to fishing occurring a long distance offshore (Figure 5-2), outside the main migration route undertaken by humpback whales off WA (How *et al.* 2020). Additionally, the entire fishery is estimated to have less than 100 vertical lines in the water at any given time which further reduces the likelihood of entanglement.

In the SCCMF, there have been only two reported entanglements with large whales since 1990, in 2015 and 2018. One whale evaded disentanglement operations, while the other was partially disentangled. As part of the shift in management of the fishery to year-round access (which increases the temporal overlap with whales), that commenced in July 2022, a series of whale entanglement mitigation measures have been introduced into the SCCMF. These broadly mirror those implemented in the WCRLMF which have proven to be successful in reducing the entanglement rate (How *et al.* 2021).

5.3.1.2 Southern right whales (*Eubalena australis*)

Southern right whales are listed as “Vulnerable” under the WA BC Act and as “Endangered” under the EPBC Act but are classified as “Least Concern” under the IUCN listings⁴.

The global population of southern right whales is estimated to be over 12,000 individuals (DSEWPac 2012). In Australia, the species forms two distinct subpopulations: a western subpopulation (in SA and WA) and a smaller eastern subpopulation (in Tasmania, Victoria and NSW) (Carroll *et al.* 2011). Western and eastern populations were most recently estimated at 2,585 (in 2020) and 268 (in 2017) individuals, respectively, with both groups increasing at about 5% per year (Stamation *et al.* 2020; Smith *et al.* 2021). The western populations was estimated at 3,164 in 2019, indicating high annual variability in sightings (Smith *et al.* 2021).

To date, there has been one interaction with southern right whales in the commercial fisheries that access the Resource (WCRLMF). This is partly due to the relatively low abundance of this species, their southern distribution, their coastal nature when in Australian waters and the offshore fishing which access the Resource, predominantly on the west coast. As the population recovers, there is a higher likelihood of interactions in future.

Southern right whales migrate from their summer feeding grounds in the Southern Ocean to calve and breed in temperate coastal waters and are seasonally present off the Australian coast between May to November (Bannister *et al.* 1996).

Southern right whales use coastal waters of the WA south coast as a calving, nursery and aggregation area during May-October. Southern right whales typically occupy coastal habitats for extended periods of time (e.g., 2-3 months for female-calf pairs at calving grounds), which increased their exposure to human activity. Shallow (<10 m) sheltered sites are preferred as nursery areas.

5.3.1.3 Pygmy blue whale (*Balenoptera musculus breviceuda*)

Blue whales (of which pygmy blue whales are a subspecies) are listed as “Endangered” under the WA BC Act and the Commonwealth EPBC Act. There are no robust abundance estimates for the Eastern Indian Ocean population of pygmy blue whales. Abundance off the west coast

⁴ http://www.environment.gov.au/cgi-bin/sprat/public/publicspecies.pl?taxon_id=40

of WA has been estimated at <1,800 individuals but it is not known what proportion of the total breeding population these individuals represent (CoA 2015).

Eastern Indian Ocean pygmy blue whales migrate between feeding grounds off southern Australia (south-west WA to Bass Strait) to breeding grounds in Indonesia, which are occupied June-September (CoA 2015). Feeding grounds are utilised from November to May. Two major seasonal feeding aggregation sites are known - the Perth Canyon (in WA) and the Bonney Upwelling system (off SA and Victoria). Feeding in the Perth Canyon occurs during January-May at 200-300 m depth.

Pygmy blue whales tend to pass along the shelf edge at depths between 500m to 1000m during their migration but may also use shallower coastal waters. Females with small calves are recorded seasonally moving through Geographe Bay in WA during September-December.

There have been no reported entanglements of pygmy blue whales in WA.

5.3.1.4 Dolphins

Reports of dolphin entanglements in pot-based fishing gear are rare. The reported 'interactions' with dolphins by the WCRLMF were observations that did not represent a physical interaction between dolphins and fishing gear.

5.3.2 Pinnipeds

Australian sea lions (ASL; *Neophoca cinerea*) and Long-nosed fur seals (LNFS; *Arctocephalus forsteri*) occur in the fishery area. Both ASL and LNFS are protected under the Commonwealth EPBC Act 1999 due to their inclusion in the Convention on International Trade in Endangered Species of Wild Fauna and Flora (CITES) Appendix II. ASLs are also currently listed as Endangered under the EPBC Act, whereas there is no additional conservation listing for LNFS. This is echoed by the Threatened and Priority Fauna List under the WA BC Act where both are listed as protected and ASLs are additionally listed as Vulnerable. Under the IUCN Red List, LNFS is listed as "Least Concern" while ASL is listed as "Endangered".

5.3.2.1 Australian sea lions (*Neophoca cinerea*)

The ASL is the only pinniped species endemic to Australia (Gales *et al.* 1992). Thirteen distinct ASL metapopulations have been identified, six in WA and seven in SA (Pitcher 2018). Breeding colonies are found from Kangaroo Island (SA) to the Houtman Abrolhos Islands (WA) (Gales *et al.* 1994). The vast majority of pup production occurs in SA (86%; Shaughnessy *et al.* 2011), which is likely to also reflect the distribution of adult animals.

Breeding colonies occur on islands or remote sections of coastline and have been recorded at 81 sites: 34 in WA and 47 in SA (Goldsworthy 2015). Of these, around 58 are considered regular breeding colonies at which five or more pups per breeding cycle have been recorded (Shaughnessy *et al.* 2011). The species is mostly coastal but is known to forage in Commonwealth waters adjacent to SA and WA (DSEWPaC 2013a).

The ASL is slow to mature (4.5-6 y for females, ≥6 y for males) and females have few young over their lifetime (Gales and Costa 1997; Goldsworthy 2015). The maximum recorded age is 26 y for females and 21.5 y for males (McIntosh 2007).

Historically, there have been deleterious interactions with ASL in pot-based fisheries due to accidental drowning of ASL pups in pots while attempting to feed on bait/captured lobsters (Campbell *et al.* 2008).

In WA, these interactions were recorded in the WCRLMF and were adjacent (<= 30km) to mainland breeding colonies on the states' mid-west coast and at the Abrolhos Islands in

shallow water (<20 m). A 2013 ERA for the Western Rock Lobster Resource assessed the ASL interaction risk as NEGLIGIBLE as the implementation of SLEDs had virtually eliminated capture of pups (Stoklosa 2013). This was re-affirmed in the 2022 ERA for this Resource which noted this issue was “not a credible threat” (Stoklosa 2022). In other pot-based fisheries the risk to ASL pups has also been largely mitigated through the use of sea lion exclusion devices (SLEDs) (Goldsworthy *et al.* 2021).

Given the shallow depth of ASL interactions, and the deep offshore location of fishing activities for the Resource on the west coast, interactions in the WCRLMF and WCDSCMF when targeting the Resource are considered to be very unlikely.

In the SCCMF, with more coastally associated fishing particularly for southern rock lobster (Figure 5-12), the risk to ASL pups has been mitigated by fitting all pots used within designated sea lion areas (Figure 4-16) with SLEDs to stop the accidental drowning of ASL.

5.3.2.2 Long-nosed fur seals (*Arctocephalus forsteri*)

In contrast to ASLs, there have been no recorded interactions between pot fisheries accessing the Resource and LNFS, which may reflect differences in feeding behaviour. Tracking of male, female (lactating) and juvenile LNFS (tagged from Kangaroo Island, SA) indicated that female foraging was continental shelf associated, while males utilised deeper shelf break waters adjacent to females. Juveniles by contrast foraged in pelagic waters up to 1000 km away from the adult foraging ground (Page *et al.* 2006), which would spatially separate them from most pot-based fishing activities for the Resource.

As for ASLs, the implementation of SLEDs mitigates any risk to LNFS (Mackay and Goldsworthy 2017).

5.3.3 Marine turtles

Marine turtle species have been reported to interact with the float line of other pot-based fisheries in WA (How *et al.* 2022b; Stoklosa 2022). Therefore, it is possible that interactions with turtles may occur with WCDSCMF and SCCMF gear. However there have been no reports of interactions. The likelihood of interactions with turtles is considered to be low in the WCDSCMF given the small number of vertical lines (<100) in the fishery with which turtles may become entangled.

Interactions with marine turtles in the SCCMF are unlikely given turtles are largely found in the north of Australia⁵.

5.3.4 Other ETP species

The Offshore Crustacean Resource overlaps with the distribution of a number of other ETP species. However, other than the interactions discussed above, there are no other reported (or known) interactions between fisheries accessing the Resource and ETP species. This includes no reported interactions with sea birds, protected sharks and rays, sea snakes or syngnathids.

5

<https://www.aims.gov.au/research-topics/marine-life/marine-turtles#:~:text=Australian%20marine%20turtles%20are%20found,and%20mangroves%20in%20tropical%20regions>. (accessed 31 Oct. 22)

5.4 Habitats

Fishing activities have the potential to impact on the structure of local aquatic habitats. Habitats may include substrates like sand or rock, but also include aquatic plants or sessile biota that provide essential habitats for many other species. Impacts could include damage from contact with fishing gear, anchors or moorings, or indirectly through boat movements (e.g., wave action, increased turbidity).

Targeting of deep sea crabs typically occurs in deep waters (>150 m) on the continental shelf and slope off the west and south coasts of WA which typically have slightly gravelly mud or sandy mud substrates (Potter *et al.* 2006; Figure 5-15). Further evidence of the types of benthic habitats in water depths >150m is provided by McEnnulty *et al.* (2011) who studied deep water invertebrates from Australia's western continental margin. The study collected benthic samples from 19 sites from Barrow Island to Albany on the deep continental shelf (100 m depth) and upper continental slope (400 m), with multibeam mapping and towed video footage of the benthos also collected (Figure 5-16). Based on the limited available evidence, when targeting deep sea crabs the most commonly encountered benthic habitats are likely to be unconsolidated sediments with or without sparsely distributed sessile invertebrates (Potter *et al.* 2006; McEnnulty *et al.* 2011).

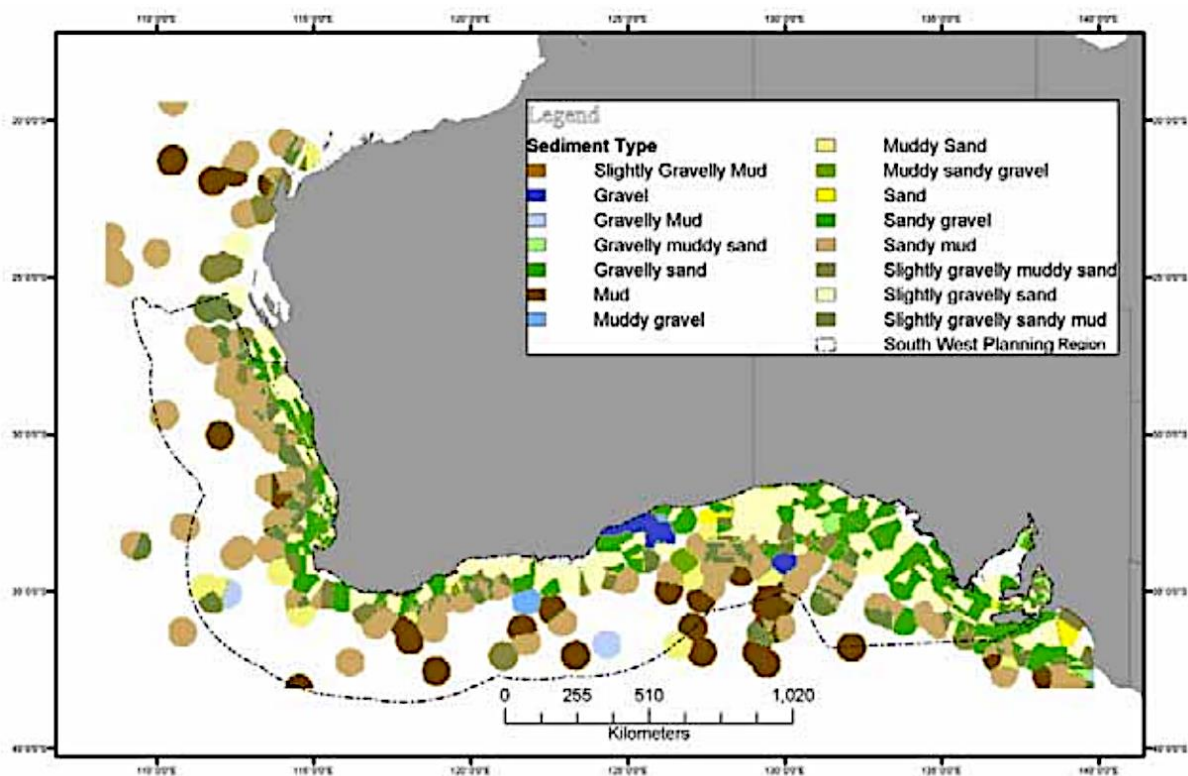

Figure 5-15 Map showing the Folk Classification of seabed sediments in the southwest planning region. Source Potter *et al.* (2006)

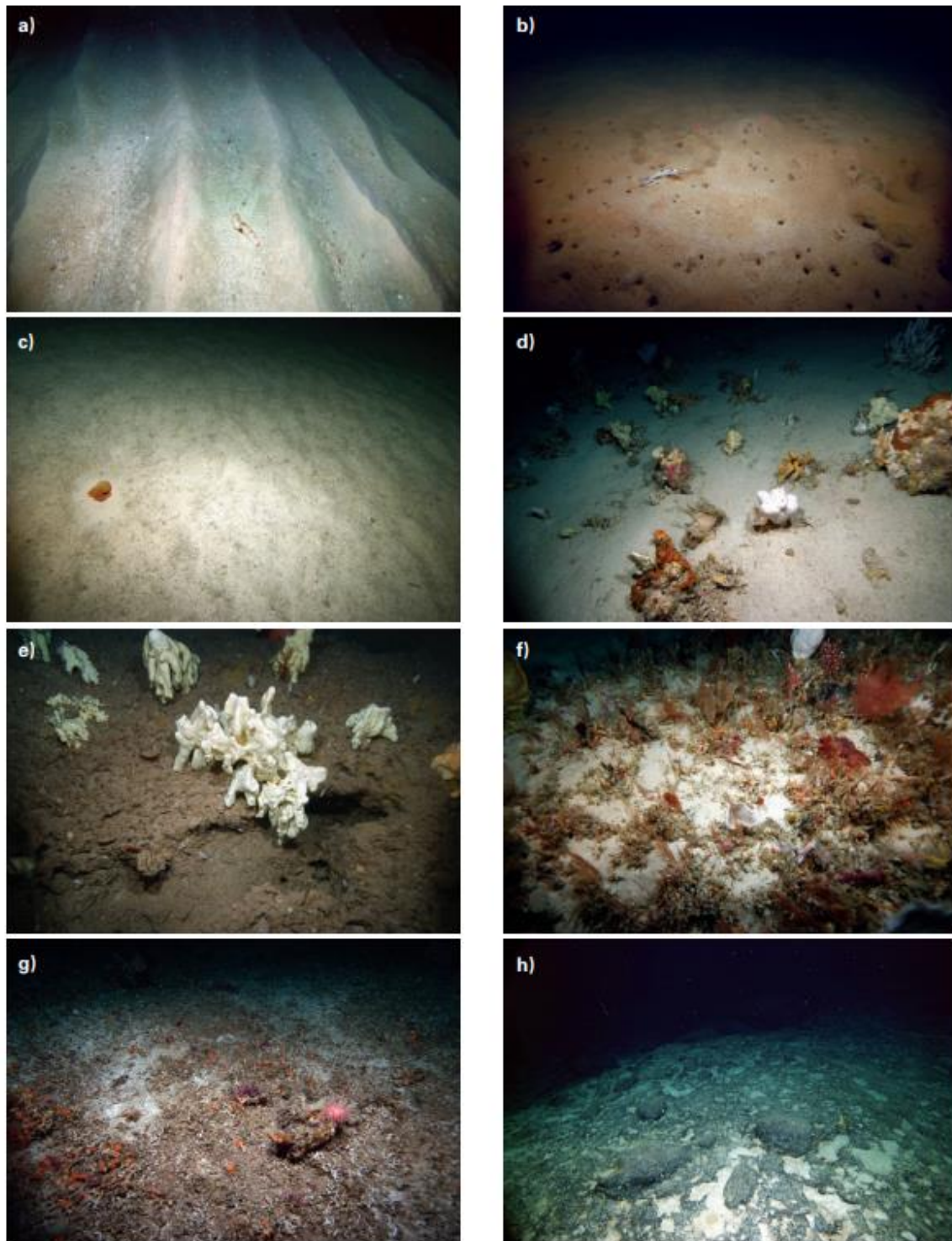

FIGURE 3 Example images of habitat types sampled along the western continental margin of Australia taken with the towed, high-resolution video and still image system on the SS200507 survey: (a) hard rippled sand (site 13 – Zuytdorp, 100 m depth); (b) Soft muddy sediments (site 18 – Ningaloo, 200 m depth); (c) sand (site 17 – Point Cloates, 400 m depth); (d) layer of sand over hard substrate (site 2 – Albany, 200 m depth); (e) reef (site 18 – Ningaloo, 100 m depth); (f) sandy reef (Site 13 – Zuytdorp, 100 m depth); (g) deep coral on seamount (site 2 – Albany, 1000 m); (h) deep bare rock (site 2 – Albany, 1000 m depth).

Figure 5-16 Extract from McEnulty *et al.* (2011) highlighting habitat types on the continental shelf off the west coast of Western Australia at depths ≥ 100 m.



Figure 5-17 Images of (left) commercial WCDSMF crystal crab pot fitted with light and camera system, and (right) crystal crab and associated habitat.

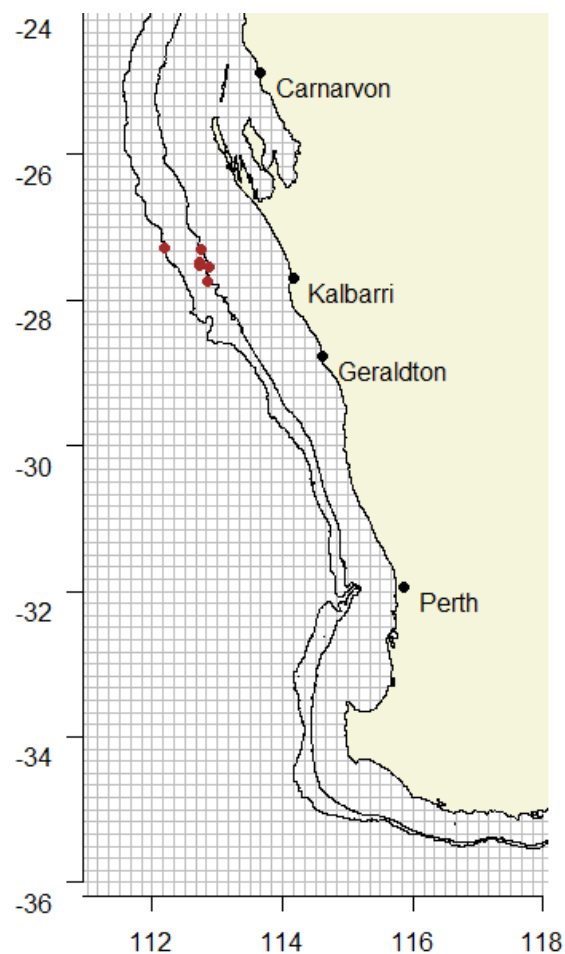

Figure 5-18 Location of camera drops to determine the habitat encountered by the West Coast Deep Sea Crustacean Managed Fishery. 500 and 1000 m isobaths are shown (black lines)

A research program has recently been initiated by the DPIRD to better understand the deep water habitats off the WA west coast. Funded by the MSC Ocean Stewardship Fund, the project uses autonomous camera systems fitted to WCDSMF pots to record images of the benthic habitat (Figure 5-17). The program has only just commenced but the first six locations

sampled (Figure 5-18) all had the same “mud” type habitat illustrated in Figure 5-17. This is consistent with fishers understanding of the habitat on the fishing grounds.

Targeting of southern rock lobster occurs in inner and outer shelf waters off the south coast (Figure 5-12). In inshore areas along the south coast, sediments display a high proportion of sand (Potter *et al.* 2006; Kendrick *et al.* 2005; Figure 5-19). In their survey of the Recherche Archipelago, Kendrick *et al.* (2005) also noted that drop camera surveys indicated soft substrate environments ranging from fine sands to gravel with very little mud.

Kendrick *et al.* (2005) classified the inshore (<50 m depth) benthic habitats in the surveyed area into the following five broad types: low profile reef (33.3% of mapped area), sand (28.3%), seagrass (20.1%), rhodoliths (13.7%), and high profile reef (4.6%) (Figure 5-19). High and low profile reef habitats contained macroalgae and/or filter-feeders, with some low profile reef habitat also containing seagrass and sand.

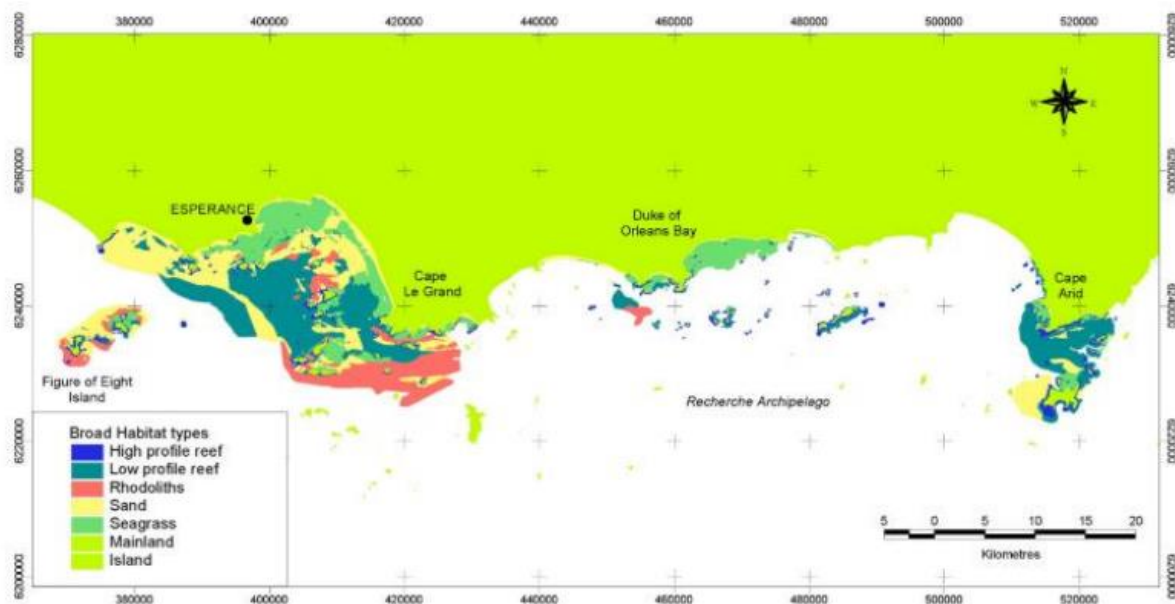

Figure 5-19 Benthic habitats of the Recherche Archipelago. White area = not sampled. Source; Kendrick *et al.* (2005)

5.5 Ecosystem Structure

5.5.1 Trophic effects

5.5.1.1 Removal of species

Removal of a species from the environment has the potential to alter key elements of the local ecosystem including trophic (food web) structure and function.

Deep sea crabs are predominantly classified as opportunistic predators and scavenger feeders, due to the nature of their habitat and limited foods sources available (How *et al.* 2015; Farrelly and Ahyong 2019). The scarcity of prey and limited historical studies suggest deep sea crabs are likely to be low in the deep water food chain, with limited trophic interactions (How *et al.* 2015). There are no known obligate predators of deep sea crabs.

Little is known of the diet of crystal crab (*Chaceon albus*), however studies from deep sea crab species of the same genus (*Chaceon*) have identified ray-finned fishes, marine carrion, gastropods and other sediment crustaceans as their primary food source. Historic gut content and stable isotope analyses indicate low feeding activity, conducive with scavenging and active predation habits (Domingos *et al.* 2007). Champagne crabs are often captured as a by-product of efforts targeting WRL, suggesting similar opportunistic scavenging feeding behaviours (Smith *et al.* 2004a). Little is known on the specific diet and trophic interactions of champagne crabs.

Diet composition and feeding habits of giant crabs have been well studied in controlled tank environments and the analysis of gut contents from wild-caught individuals. *P. gigas* have low diet diversity, predominantly feeding on gastropod molluscs, asteroid echinoderms and other decapod species (Heeren and Mitchell 1997; Levings *et al.* 2001). Diet composition varies depending on size, sex and moult-status. Females have been found to consume more gastropods than males, with males predominantly feeding on asteroids. Crabs of smaller size (<2.5 kg) feed mainly on gastropods, while larger crabs (>2.5 kg) consume more asteroids. Historical studies have found the stomachs of crabs in a pre-moult stage to be empty, with post-moult crabs containing a higher percentage of asteroids. Inter-moult crabs had gut-contents consisting of mostly gastropods (Levings *et al.* 2001). Due to the nature of their preferred habitat, predation of giant crabs is assumed to be low. In controlled tank studies intra-specific predation has been observed (Leving *et al.* 2001).

Southern rock lobsters (SRL) are omnivorous generalist feeders, primarily consuming a wide range of slow-moving benthic invertebrates (Linnane *et al.* 2011b). Their preferred prey are molluscs, small crustaceans, echinoderms and other benthic invertebrates. Gut content analyses have shown macroalgae and coralline algae to be significant dietary components across their distribution (MacDiarmid *et al.* 2013). In areas of high lobster biomass, urchin and coralline turf abundance is often low, demonstrating a considerable top-down trophic cascade. In areas of high density, lobsters also exhibit cannibalistic behaviours, with predominantly larger lobsters feeding on smaller or post-moult lobsters (MacDiarmid *et al.* 2013).

Feeding patterns differ between moult and reproductive seasons. Male and female lobsters discontinue feeding during mating periods between April and July, and males will not feed again during their moult in October (Linnane *et al.* 2011b; MacDiarmid *et al.* 2013). SRL are nocturnal foragers, feeding on residential rock reef systems and adjacent sand flats (Langlois *et al.* 2006).

The major predators of both adult and juvenile southern rock lobster are believed to be octopus, gummy sharks, a variety of larger finfish and marine mammals. Octopus-driven mortalities are the most commonly observed form of depredation on pot-trapped lobsters, although depredation rates significantly decrease with depth (Briceno *et al.* 2015). Small juvenile lobsters are the most susceptible to predation, with vulnerability decreasing with increasing size. Smaller lobsters reduce foraging efforts when predatory fish are present, thus increasing survival rates but lowering growth rates (MacDiarmid *et al.* 2013).

5.5.1.2 Provisioning

The addition of bait to the environment can represent an extra source of nutrition for certain organisms, which may increase in abundance as a result. Such 'provisioning' has the potential to alter key elements of the local ecosystem including trophic (food web) structure and function.

The deep sea environment is naturally oligotrophic (nutrient poor) and so the addition of nutrients may have a greater effect here than in other environments that are naturally higher in nutrients.

Currently, the total quantity of bait used annually to target deep sea crustaceans is estimated to be about 77 t on the west coast (by the WCDSCMF) with additional provisioning from the estimated 73 t used offshore by the WCRLMF while targeting deep sea crabs and deep water migrating rock lobsters. About 21 t of bait is estimated to be used annually on the south coast by the SCCMF.

5.5.2 Translocation (pests and disease)

5.5.2.1 Vessels and equipment as vectors

Pests and diseases may be transferred via vessels in wet areas such as bilges, decks, anchor wells and sea chests and in niche area of the hull. Fishing vessels may present additional areas including on wet fishing gear or holding tanks. Overall, fishing vessels are typically rated very low risk in terms of translocation of marine pests and diseases at an international scale but examples of local transmission of pest species such as *Undaria pinnatifida* can be identified (Bridgwood and McDonald 2014).

Given that commercial fishers are not permitted to use their boats or gear outside of Australian waters, the risk of international transmission of introduced marine pests and diseases is effectively zero. At a local level, the vessels operating in the WCDSCMF, SCCMF and WCRLMF have low susceptibility to inoculation from pests and diseases because they typically work in remote ocean locations and from a limited number of predominantly low-risk ports.

During 2021, there were six vessels actively fishing in the WCDSCMF, which each utilised between one and five ports for their fishing operations (Table 5-10).

Table 5-10 Number of unique ports each fishing vessel utilised when fishing for offshore crustaceans by year in the WCDSCMF.

Season	Number of Ports				
	1	2	3	4	5
2017	1	2	1		
2018	2	2			
2019	4				
2020	3	2			
2021	1	2			1

Trip-based returns have been submitted by the SCCMF since 2019/20 and provide data on the ports utilised. The majority of vessels utilised a single port throughout a season for their fishing operations, with only a few vessels utilising multiple ports (Table 5-11).

For the WCRLMF fleet, over half of all vessels fished exclusively from one port, with 95% of the fleet using 3 or less landing areas throughout a season (Table 5-12).

This suggests a negligible risk of translocation of pests and diseases due the activity of this fishery.

Table 5-11 Number of fishing vessel and the number of unique ports that they utilised when fishing for offshore crustaceans in the SCCMF by season.

Season	Number of Ports			
	1	2	3	4
2019-20	9	2	1	
2020-21	6	1		1
2021-22	6			

Table 5-12 Number of WCRLMF vessels and the number of unique landing areas used by year. The total number of vessels fishing in each year is also presented along with the five-year average proportion of vessels using landings areas.

Year	No. of Landing Areas							No. Vessels
	1	2	3	4	5	6	7	
2017	110	76	30	13	2	3		234
2018	116	76	37	7	1		1	238
2019	123	67	39	8			1	238
2020	128	67	33	8	2			238
2021	127	65	33	8	1			234
Mean Proportion	0.51	0.3	0.15	0.04	0.01	0	0	

5.5.2.2 Bait as a vector

Exotic pests and diseases may be introduced to the local marine environment via bait that has been imported into WA.

Currently, >100 t of bait is estimated to be used annually to target deep sea crustaceans in WA waters. The vast majority (80-95% by weight) of this bait is wild-caught marine fish imported from New Zealand, with the remainder being wild-caught marine fish from WA, plus smaller quantities of fish and pork products from elsewhere in Australia.

The importation of non-salmonid fish from New Zealand for use as bait is permitted under the terms of the *Australia New Zealand Closer Economic Relations Trade Agreement*. Under this agreement, both countries cooperate on biosecurity to facilitate trade and travel, meaning that, where possible they recognise each other's systems to manage biosecurity risk, and take a consistent approach to biosecurity risk assessment and management of imports from third countries⁶.

All imported bait is frozen. Freezing reduces the disease risk compared to fresh bait because freezing kills some pathogens, including protozoans, metazoans and some bacteria. However, some bacteria and other pathogens, including most viruses, can survive freezing (Diggles 2011).

In 1995 and 1998–99, mass mortalities (60-70%) occurred in the Australian populations of pilchard (*Sardinops sagax neopilchardus*) due to the Pilchard Herpesvirus (PHV) which is thought to have been introduced to Australian waters via imported bait that was fed to caged southern bluefin tuna in South Australia (Gaughan 2002; Whittington *et al.* 2008). There is

⁶ <https://www.agriculture.gov.au/biosecurity-trade/policy/partnerships/consultative-committees/cgbc>

evidence of major changes to pelagic food webs as result of these mortalities, including negative impacts on predator populations (Bunce and Norman 2000; Dann *et al.* 2000; Ward *et al.* 2001; Taylor and Roe 2004; Chiaradia *et al.* 2010; Kliska *et al.* 2022).

The use of imported bait to target WRL by the WCRLMF (which uses a larger amount of bait than the offshore crustacean fisheries) has previously been assessed to be a low risk, largely based on the evidence of many decades of bait use by this industry that has not resulted in any reported significant disease events to date (Jones and Gibson 1997; Kahn *et al.* 1999).

5.5.3 Ghost fishing

For the purpose of fisheries management, the gear used by the various fisheries is referred to as either pots or traps. Irrespective of their designation in management plans or regulations, all gear used acts as a pot. This permits the ingress and egress of animals in/out of the pot, as opposed to a trap which markedly reduces the egress of animals once they have entered the trap. For this reason, if they are lost, pots have greatly reduced potential for ghost fishing compared to traps.

The potential for ghost fishing in the offshore crustacean fisheries is very low as pots are designed with mandatory escape gaps. In the SCCMF, lost gear reporting is mandatory, including details of any pots subsequently found. To better understand the extent of gear loss in the WCDSMF, mandatory reporting of any lost gear, and any subsequent recovered gear was introduced on 1 January 2022. To date, there have been no reported lost pots from the WCDSMF. When gear “snaps off”, there is a significant financial impost on fisher to replace it. They often undertake grappling to recovered lost parts of lines and are very effective at retrieving lost lines / parts of lines. Additionally commercial fishers use wooden batten pots when fishing for some species in the Resource, particularly champagne crabs, and those pots which are lost eventually breakdown as the wood decays rapidly in the marine environment. Furthermore, once the bait disintegrates, species are less likely to be attracted into the pot. Given these factors, ghost fishing is considered unlikely to occur in the fishery.

5.6 Broader Environment

Australia abides by the International Convention for the Prevention of Pollution from Ships (MARPOL) which includes regulations aimed at preventing both accidental pollution and pollution from routine vessel operations. MARPOL prohibits the disposal at sea of all types of pollution including gas emissions, sewage, plastics and other garbage, oil and other harmful substances. Australia implements MARPOL through the *Protection of the Sea (Prevention of Pollution from Ships) Act 1983*, *Navigation Act 2012*, *Marine order 95 (Marine pollution prevention- garbage) 2013*, *Marine Order 91 (Marine pollution prevention- oil) 2014*, *Marine Order 97 (Marine pollution prevention-air pollution) 2013* and other Commonwealth legislation. In WA, MARPOL is partly implemented through the *Pollution of Waters by Oil and Noxious Substances Act 1987*.

5.6.1 Air quality

Commercial fishing vessels burn fuel which has the potential to reduce air quality through the emission of gases and particulates into the air. In 2021, there were six vessels in the WCDSMF which undertook a total of 160 fishing trips for offshore crustaceans. These were typically three-day fishing trips, resulting in a total of about 480 fishing days in 2021.

The SCCMF had six vessels operating in 2021/22 that averaged 36 fishing days each during the 2021/22 season, resulting in a combined total of 215 days.

Currently, there are 235 vessels actively fishing in the WCRLMF for western rock lobster. However, only 20 vessels reporting catches of champagne crab, taken during a total of 157 fishing days in 2021.

These fleets operate over a large geographical area and the impact of vessel emissions on air quality over this area is expected to be minor.

5.6.2 Water quality

Commercial fishing vessels have the potential to reduce water quality through discarding of debris and litter (see below) as well as by accidental oil and fuel spills. The WCDSCMF, SCCMF and WCRLMF operate over large geographical areas and the impact of accidental spills on water quality over this area is expected to be negligible.

Marine pollution due to sewage and sullage is regulated at the international, national and state levels. Recreational and commercial vessels are required to operate in accordance with the WA Department of Transport's Strategy for Management of Sewage Discharge from Vessels into the Marine Environment. The strategy provides guidance for managing the discharge of sewage from vessels into the marine environment.

5.6.3 Noise pollution

Water is an efficient medium for transporting sound waves. In the marine environment sound transmission is highly variable and can be dependent on the acoustic properties of the seabed and surface, variations in sound speed and the temperature and salinity of the water (Richardson *et al.* 1995).

For most marine animals, sound is important for communication, for locating prey and peers, and for short-range and long-range navigation (Erbe *et al.* 2015, 2018; Evans *et al.* 2016; Hawkins and Popper 2017). Both chronic and acute noise pollution can cause detectable effects on intra-specific communication, vital processes, physiology, behavioural patterns (e.g., larval settlement, predator avoidance), health status and survival (e.g., Di Franco *et al.* 2020). Depending on the level and duration of noise, effects on species may be temporary or permanent.

Little is known regarding specific effects of noise on most marine species in Australia. However, globally, there is strong evidence for noise impacts on marine mammals, and numerous studies have also found impacts to fish, invertebrates, marine birds and reptiles (Duarte *et al.* 2021).

The main anthropogenic activities producing high levels of noise in the marine environment are seismic surveys of sub-bottom strata, active sonars, explosions, pile driving, vessels, dredging and drill rig activities (Evans *et al.* 2016).

The size of vessels (10-30 m) and low-density nature of fishing mean any impact of noise pollution from WCDSCMF, SCCMF and WCRLMF vessels is expected to be minor.

5.6.4 Litter

Commercial fishers are likely to generate some waste/rubbish while fishing (e.g., bait packaging, food wrappers, drink containers, rope cut-offs). The dumping of rubbish at sea is prohibited under the WA *Navigable Water Regulations 1958*. Fishers are encouraged to store waste and rubbish on the vessel and disposal of it appropriately when back on land. While difficult to quantify, there is thought to be a high level of stewardship amongst fishers with a low level of intentional littering. However, there is evidence of floats and ropes which wash up on shores, some of which may be from boat strikes on gear or rough weather.

In response to concerns of discarded bait bands from the fishery, a state-wide ban on bait bands on fishing vessels was implemented on the 15 November 2011 (de Lestang *et al.* 2021).

6.0 External Factors

While a number of external influences and activities (e.g. urban developments, dredging, climate change) have the potential to impact the productivity and sustainability of the Resource and the broader ecosystem, these are not explicitly included within the scope of this current ERA (see Section 7.1).

The impacts of external factors on species and their habitats will be reflected in the data collected for each fishery - for example, age and/or length composition, catch and effort distribution, rates of recruitment and mortality, and biomass trends. Current and future impacts of external factors, such as climate change, are considered in the risk-based weight-of-evidence stock assessments conducted for primary retained species. The risks posed by external factors are then managed through the harvest strategy for the Resource.

7.0 Risk Assessment Methodology

The risk analysis methodology used for this ERA is based on the global standard for risk assessment and risk management (AS/NZS ISO 31000), which has been adopted for use in a fisheries and aquaculture context (see Fletcher *et al.* 2002, Fletcher 2005; 2015). The broader risk assessment process is summarised in *Policy for the Implementation of Ecologically Sustainable Development for Fisheries and Aquaculture Within Western Australia* (Department of Fisheries 2002) and in Figure 7-1.

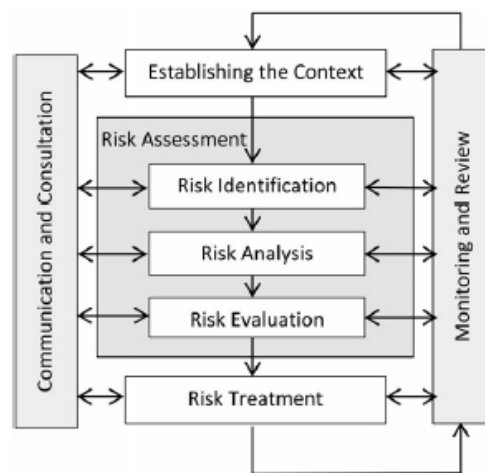

Figure 7-1 Position of risk assessment within the risk management process.

The first stage establishes the context or scope of the risk assessment, including determining which activities and geographical extent will be covered, a timeframe for the assessment and the objectives to be delivered. Secondly, risk identification involves the process of recognising and describing the relevant sources of risk. Once these components have been identified, risk scores are determined by evaluating the potential consequences (impacts) associated with each issue, and the likelihood (probability) of a particular level of consequence occurring.

Risk evaluation is completed by comparing the risk scores to established levels of acceptable and undesirable risk to help inform decisions about which risks need treatment. For issues with levels of risk that are considered undesirable, risk treatment involves identifying the likely monitoring and reporting requirements and associated management actions, which can either address and/or assist in reducing the risk to acceptable levels.

7.1 Scope

This ERA assessed the potential ecological impacts of harvesting the Resource within WA waters, as required to inform the harvest strategy for the Resource and meet MSC and EPBC Act assessment requirements.

Individual and cumulative risks of specific activities and their impact on each ecological component will be scored across all relevant fishing sectors.

In WA, most primary retained species are managed under a harvest strategy against biologically based reference levels, and the risk of all fishing on the broader stock(s) has typically already been determined as part of their stock assessments. Thus there was no need to re-evaluate these scores in the ERA workshop. Instead, the ERA workshop focused on assessing the risks of fishing impacts on bycatch and ETP species, benthic habitats and the broader ecosystem.

The calculation of risk in the context of a fishery is usually determined within a specified period, which for this assessment is the next five years (i.e., until 2027). It is envisioned that ERAs will be undertaken periodically (approximately every five years) to reassess new risks or changes to existing risks that may occur during that period. A new risk assessment may also be triggered if there are significant changes identified in fishery operations or management activities that may change current risk levels.

For the purpose of this assessment, risk is defined as *the uncertainty associated with achieving a specific management objective or outcome* (adapted from Fletcher 2015). For DPIRD, 'risk' is the chance of something affecting DPIRD's performance against the objectives laid out in their relevant legislation. In contrast, for the commercial fishing industry, the term 'risk' generally relates to the potential impacts on their long-term profitability. For the general community, 'risk' could relate to possible impact on their enjoyment of the marine environment. The aim for each of these groups is to ensure the 'risk' of an unacceptable impact is kept to an acceptable level.

7.2 Risk Identification

The first step in the DPIRD risk assessment process is to identify ecological issues relevant to the Resource and fishery being assessed. Ecological issues are examined using a component tree approach, where major components are deconstructed into smaller sub-components that are more specific to allow the development of operational objectives (Fletcher *et al.* 2002). Component trees are broadly similar for all WA Aquatic Resources assessed by DPIRD but are tailored to suit the individual circumstances of each Resource by adding and expanding some components and collapsing or removing others.

A preliminary component tree (Figure 7-2) was developed for the Offshore Crustacean Resource based on:

- analysis of current fishing activities;
- previous risk assessments for the Resource;

- previous Commonwealth assessments for the commercial fisheries under Parts 13 and 13A of the EPBC Act;
- MSC assessments of the commercial fisheries;

The preliminary component tree was modified during the ERA workshop to develop the final component tree (Figure 8-1).

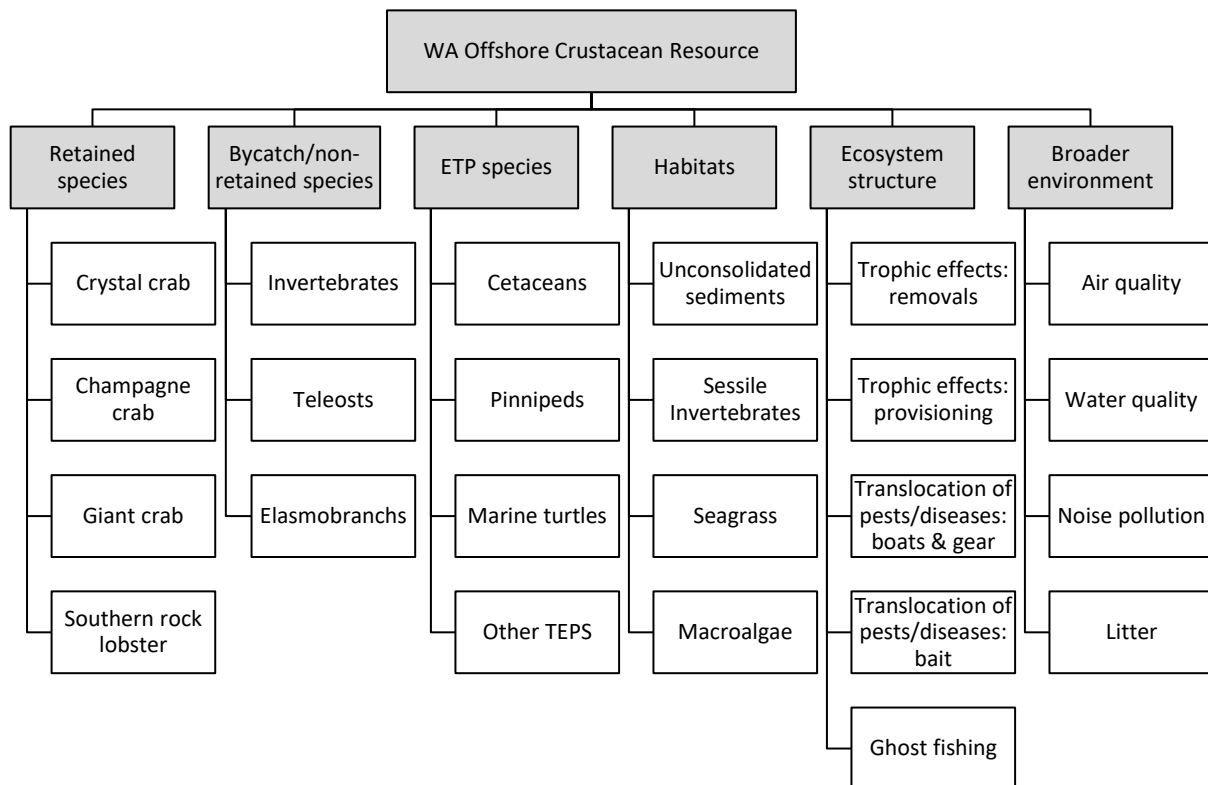

Figure 7-2 Preliminary component tree for assessing the ecological sustainability of the Offshore Crustacean Resource

7.3 Previous Risk Assessments for the Resource.

An ERA for the WRL Resource was undertaken by a workshop involving internal (departmental) and external stakeholders in 2022 (How *et al.* 2022b; Stoklosa 2022).

Internal (departmental) risk assessments were conducted for the SCCMF in 2002 and for the WCDCMF in 2014 (How *et al.* 2015).

7.4 Risk Assessment Process

An important part of the risk assessment and risk management process is communication and consultation with stakeholders. ERAs undertaken by DPIRD typically engage all relevant stakeholders through participation in the ERA workshop.

To prioritise management actions, the risk assessment process separates minor acceptable risks from major unacceptable risks. This process utilises a consequence-likelihood analysis, which examines the magnitude of potential consequences from fishing activities and the

likelihood that those consequences will occur given current management controls (Fletcher 2015).

This assessment utilised the 4x4 risk matrix in Appendix 1. The consequence levels range from 1 (minor impact) to 4 (major impact) and likelihood levels range from 1 (Remote) to 4 (Likely). For each issue, the consequence and likelihood levels are evaluated to determine the highest risk score using the risk matrix. Each issue is then assigned a risk level within one of five categories: Negligible, Low, Medium, High or Severe.

Scoring involves assessing the likelihood that a consequence level is occurring, or will occur, within a 5-year period.

The various likelihood and consequence levels are defined in tables in Appendix 2. Five consequence tables were used in this ERA to accommodate the variety of issues and potential outcomes:

- Target/retained species – measured at a stock level;
- Bycatch/non-retained species – measured at a stock level;
- ETP species – measured at a population or regional level;
- Habitats – measured at a regional level; and
- Ecosystem/Environment – measured at a regional level.

8.0 Risk Analysis

Forty three ecological components were identified as potentially impacted by WA Offshore Crustacean harvesting (Figure 8-1).

The risk ratings for each ecological component considered in the assessment are summarised in Table 8-1. The risk justifications given below include comments from stakeholders that attended the workshop. While these are a summary of individual views and may not be representative of every stakeholder at the workshop, the risk scores are reflective of the group consensus at the workshop.

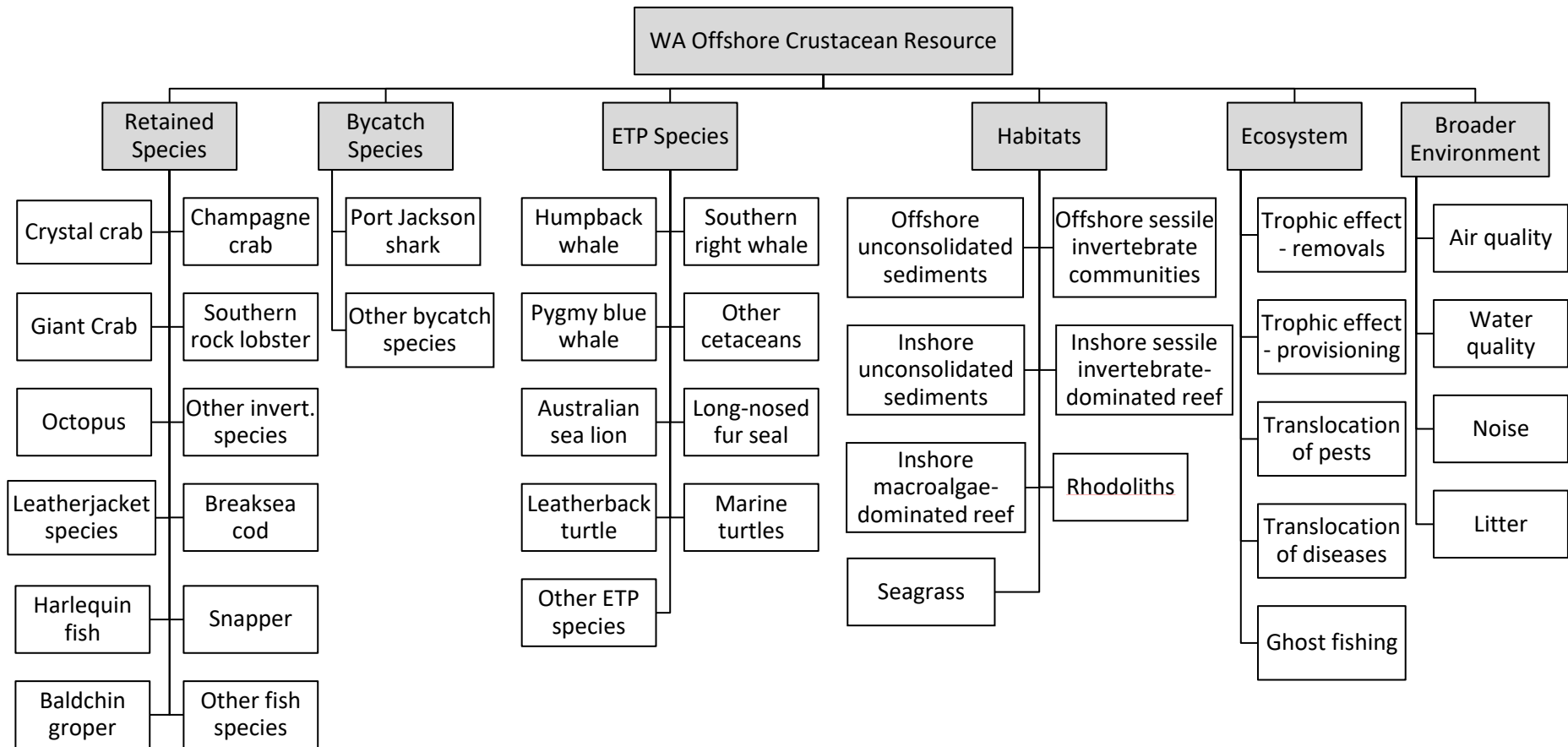

Figure 8-1 Component tree used in this ERA for assessing the ecological sustainability of the WA Offshore Crustacean Resource

Table 8-1 Overview of the objectives, components, and risk scores and ratings considered in the 2022 ecological risk assessment of the fishery for the WA Offshore Crustacean Resource. (*existing assessment, not scored in this ERA)

Aspect	Fishery Objective	Component	Fishing activities	Risk Scoring	Risk rating
Retained species (primary)	To maintain biomass of each retained species at a level where the main factor affecting recruitment is the environment	Crystal crab (west coast)	All fishing on stock	C4, L3	SEVERE*
		Crystal crab (SCCMF zone 2)	All fishing on stock	C2, L3	MEDIUM*
		Champagne crab (west coast)	All fishing on stock	C3, L2	MEDIUM*
		Champagne crab (SCCMF zone 2)	All fishing on stock	C3, L4	HIGH*
		Giant crab (SCCMF zone 2)	All fishing on stock	C3, L4	HIGH*
		Giant crab (SCCMF zone 3)	All fishing on stock	C3, L4	HIGH*
		Southern rock lobster (SCCMF zone 3)	All fishing on stock	C3, L4	HIGH*
		Southern rock lobster (SCCMF zone 4)	All fishing on stock	C2, L4	MEDIUM*
Retained species (secondary)	To maintain biomass of each retained species at a level where the main factor affecting recruitment is the environment	Octopus	Offshore Crustacean fishing	C1, L1	NEGLIGIBLE
		Other invertebrate species	Offshore Crustacean fishing	C1, L1	NEGLIGIBLE
		Leatherjacket species	Offshore Crustacean fishing	C2, L1	NEGLIGIBLE
		Breaksea cod	Offshore Crustacean fishing	C1, L1	NEGLIGIBLE
		Harlequin fish	SCCMF	C1, L1	NEGLIGIBLE
		Snapper (WCB)	WCRLMF	C4, L1	LOW
		Baldchin groper (WCB)	WCRLMF	C3, L1	LOW
		Other fish species	Offshore Crustacean fishing	C1, L1	NEGLIGIBLE
Bycatch species (non-retained)	To ensure fishing impacts do not result in serious or irreversible harm to bycatch species populations	Port Jackson shark	Offshore Crustacean fishing	C2, L1	NEGLIGIBLE
		Other bycatch species	Offshore Crustacean fishing	C1, L1	NEGLIGIBLE
ETP species	To ensure fishing impacts do not result in serious or irreversible harm to ETP species' populations	Humpback whale	Offshore Crustacean fishing	C2, L2	LOW
		Southern right whale	Offshore Crustacean fishing	C3, L1	LOW

		Pygmy blue whale	Offshore Crustacean fishing	C3, L1	LOW
		Other cetacean species	Offshore Crustacean fishing	C1, L1	NEGLIGIBLE
		Australian sea lion	Offshore Crustacean fishing	C4, L1	LOW
		Long-nosed fur seal	Offshore Crustacean fishing	C1, L1	NEGLIGIBLE
		Leatherback turtle	Offshore Crustacean fishing	C2, L1	NEGLIGIBLE
		Other marine turtle species	Offshore Crustacean fishing	C1, L1	NEGLIGIBLE
		Other ETP species	Offshore Crustacean fishing	C1, L1	NEGLIGIBLE
Habitats	To ensure the effects of fishing do not result in serious or irreversible harm to habitat structure and function	Offshore unconsolidated sediments	Offshore Crustacean fishing	C1, L1	NEGLIGIBLE
		Offshore sessile invertebrate communities	Offshore Crustacean fishing	C2, L1	NEGLIGIBLE
		Inshore unconsolidated sediments	Offshore Crustacean fishing	C1, L1	NEGLIGIBLE
		Inshore reefs – Macroalgae dominant	Offshore Crustacean fishing	C2, L1	NEGLIGIBLE
		Inshore reefs – Sessile invertebrates dominant	Offshore Crustacean fishing	C2, L2	LOW
		Rhodolith beds (inshore)	Offshore Crustacean fishing	C1, L2	NEGLIGIBLE
		Seagrass beds (inshore)	Offshore Crustacean fishing	C1, L1	NEGLIGIBLE
Ecosystem Structure	To ensure the effects of fishing do not result in serious or irreversible harm to ecological processes	Trophic interactions - removals	Offshore Crustacean fishing	C2, L1	NEGLIGIBLE
		Trophic interactions - provisioning	Offshore Crustacean fishing	C2, L1	NEGLIGIBLE
		Translocation of pests	Offshore Crustacean fishing	C1, L1	NEGLIGIBLE
		Translocation of diseases	Offshore Crustacean fishing	C3, L2	MEDIUM

Broader Environment	To ensure the effects of fishing do not result in serious or irreversible harm to the broader environment	Ghost fishing (lost gear)	Offshore Crustacean fishing	C1, L2	NEGLIGIBLE
		Air quality	Offshore Crustacean fishing	C1, L1	NEGLIGIBLE
		Water quality	Offshore Crustacean fishing	C1, L1	NEGLIGIBLE
		Noise pollution	Offshore Crustacean fishing	C1, L1	NEGLIGIBLE
		Litter	Offshore Crustacean fishing	C1, L3	LOW

8.1 Retained species

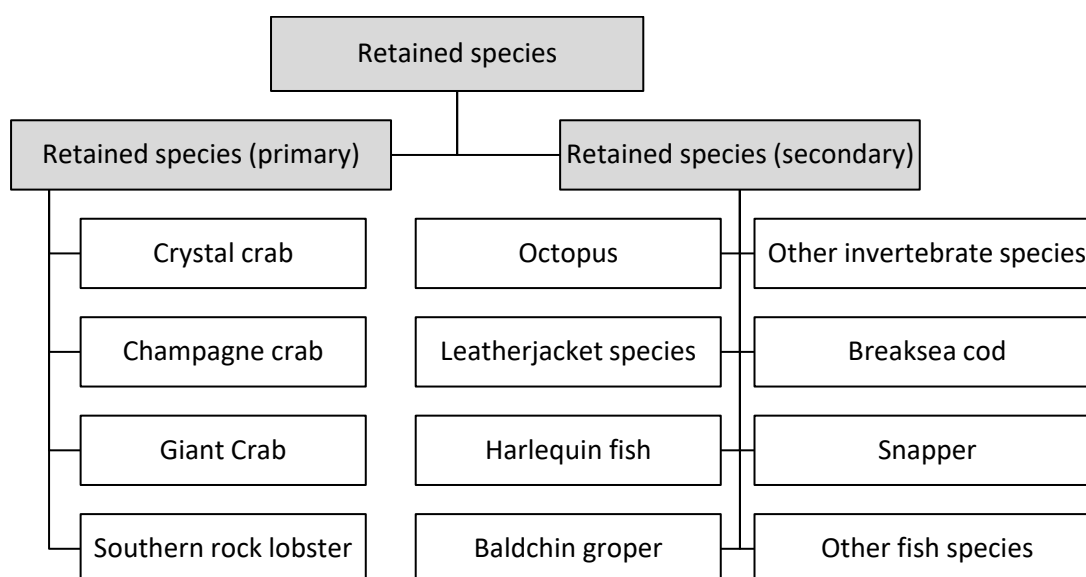

8.1.1 *Crystal crab (Chaceon albus)*

Risk Rating: Impact of all fishing on the west coast stock of crystal crab (C4×L3= SEVERE).

Risk Rating: Impact of all fishing on the SCCMF zone 2 stock of crystal crab (C2×L3= MEDIUM).

- Risk ratings are based on the most recent (2021) stock assessments undertaken by DPIRD, not re-assessed in this ERA workshop.
- In 2022, the WCDSCMF TACC was reduced by 20% to reduce the risk to the west coast crystal crab (see Sections 4.1.2 and 5.1.1).

8.1.2 *Champagne crab (Hypothalassia acerba)*

Risk Rating: Impact of all fishing on the west coast stock of champagne crab (C3×L2= MEDIUM).

Risk Rating: Impact of all fishing on the SCCMF zone 2 stock of champagne crab (C3×L4= HIGH).

- Risk ratings are based on the most recent (2021) stock assessments undertaken by DPIRD, not re-assessed in this ERA workshop.
- In 2022/23, a new ITQ system was implemented for the SCCMF, including a 5 t TACC for champagne crabs in Zone 2 which is expected to reduce the risk to this stock (see Sections 4.2.2 and 5.1.2).

8.1.3 *Giant crab (Pseudocarcinus gigas)*

Risk Rating: Impact of all fishing on the SCCMF zone 2 stock of giant crab (C3×L4= HIGH).

Risk Rating: Impact of all fishing on the SCCMF zone 3 stock of giant crab (C3×L4= HIGH).

- Risk ratings are based on the most recent (2021) stock assessments undertaken by DPIRD, not re-assessed in this ERA workshop.

- In 2022/23, a new ITQ system was implemented for the SCCMF, including TACCs for giant crab of 2 t in Zone 2 and 2.5 t in Zone 3 which are expected to reduce the risks to these stocks (see Sections 4.2.2 and 5.1.3).

8.1.4 Southern rock lobster (*Jasus edwardsii*)

Risk Rating: Impact of all fishing on the SCCMF zone 3 stock of southern rock lobster (C3×L4= HIGH).

Risk Rating: Impact of all fishing on the SCCMF zone 4 stock of southern rock lobster (C2×L4= MEDIUM).

- Risk ratings are based on the most recent (2021) stock assessments undertaken by DPIRD, not re-assessed in this ERA workshop.
- In 2022/23, a new ITQ system was implemented for the SCCMF, including a 16 t TACC for southern rock lobster in Zone 3 which is expected to reduce the risk to this stock (see Sections 4.2.2 and 5.1.4).

8.1.5 Western rock octopus (*Octopus djinda*)

Risk Rating: Impact of harvesting the Resource on the western rock octopus stock (C1×L1= NEGLIGIBLE).

- The risk to the western rock octopus stock from all fishing in WA was recently assessed by DPIRD as LOW (Hart *et al.* 2022).
- The risk to the western rock octopus stock posed by offshore crustacean fisheries was assessed as NEGLIGIBLE due to the very small quantities of octopus caught in these fisheries, relative to the total WA catch of this stock. This risk score included the cumulative impact of all retained and discarded catches of octopus by offshore crustacean fisheries.

8.1.6 Other retained invertebrate species

Risk Rating: Impact of harvesting the Resource on all other retained invertebrate species (C1×L1= NEGLIGIBLE).

- Recent records indicate very few other invertebrate species are retained by offshore crustacean fisheries, and they are taken in very low quantities.
- Over the past 3 years, a total of 20 “cape spear lobster” (*Projasus parkeri*), were reported as retained by the SCCMF. This species is widespread across the southern hemisphere but rarely caught off WA. It is saleable, but can’t be found by fishers in ‘commercial quantities’. The catch is not expected to rise over the next 5 years.
- Catches of all other retained invertebrate species by offshore crustacean fisheries were not expected to have any measurable impact on these stocks.

8.1.7 Leatherjacket species (*Monocanthidae*)

Risk Rating: Impact of harvesting the Resource on leatherjacket species (C1×L1= NEGLIGIBLE).

- Leatherjacket species often retained and used as bait by offshore crustacean fisheries. Mostly taken on south coast, rarely reported on west coast.
- These catches not always identified to species, but believed to mainly comprise ocean leatherjacket (*Nelusetta ayraudi*) and horseshoe leatherjacket (*Meuschenia*

hippocrepis). Both species regarded as relatively common/abundant across their range. Life history traits make these species moderately resilient to exploitation.

- Commercial offshore crustacean fishers regard leatherjacket species as “under exploited”.
- Total leatherjackets catch (all species combined, retained and discarded) by SCCMF in 2019/20 crustacean fisheries estimated to be ~3.5 t. Lower catches in more recent years reflect atypically low effort. Catch and effort levels could potentially return to 2019/20 levels during the next 5 years, although fishers believe that new management arrangements (e.g. shorter pot set times) make it unlikely that future catches will reach this level again.
- This quantity is a minor share of the total WA catch. In 2021, a total retained catch of ~16 t of leatherjackets (all species combined) was reported by other commercial fishers in the SCB. Minimal catches are taken by recreational fishers. Leatherjacket species are not strongly targeted by any WA fishery.
- The WA catch of ocean leatherjacket is small compared to that taken by the Commonwealth Great Australian Bight Trawl Sector Fisheries, which harvested ~150 t of the same stock in 2019/20. The Commonwealth catch has been assessed as ‘sustainable’ (Smoothey *et al.* 2021).
- Catches of leatherjackets species by the SCCMF were not expected to have any measurable impacts on these stocks.

8.1.8 *Breaksea cod (Epinephelides armatus)*

Risk Rating: Impact of harvesting the Resource on the breaksea cod stock (C1×L1= NEGLIGIBLE).

- Biological traits make this species inherently vulnerable to exploitation.
- There is no assessment of current stock status for breaksea cod.
- The total catch of breaksea cod by offshore crustacean fisheries (<100 kg per year, including retained and discarded) is very small compared to the total WA catch (~23 t in 2020/21) of this stock.
- Catches of breaksea cod by offshore crustacean fisheries were not expected to have any measurable impact on the stock.

8.1.9 *Harlequin fish (Othos dentex)*

Risk Rating: Impact of harvesting the Resource on the harlequin fish stock (C1×L1= NEGLIGIBLE).

- Biological traits make this species inherently vulnerable to exploitation.
- There is no assessment of current stock status for harlequin fish.
- Small quantities of harlequin fish are caught by the SCCMF. The total catch (<50 kg per year, including retained and discarded) is small compared to the total WA catch (~4 t in 2020/21) of this species. The species is predominantly taken by recreational and charter fishers.
- Catches of harlequin fish by the SCCMF were not expected to have any measurable impact on the stock.

8.1.10 Snapper (*Chrysophrys auratus*)

Risk Rating: Impact of harvesting the Resource on the WCB snapper stock (C4×L1= LOW).

- WCRLMF fishers retain relatively small quantities of snapper while accessing the Offshore Crustacean Resource (estimated 254 kg in 2020/21). This is very low compared to the total WCB catch of this species retained by all sectors (~180 t in 2021).
- No catches of snapper have been recorded by other offshore crustacean fisheries.
- The current risk to the WCB snapper stock from all fishing has been assessed by DPIRD as SEVERE (Fairclough *et al.* 2021).
- The workshop concluded that there was a Remote likelihood that catches of snapper by the WCRLMF taken while accessing the Resource will have a Major impact on the WCB snapper stock.

8.1.11 Baldchin groper (*Choerodon rubescens*)

Risk Rating: Impact of harvesting the Resource on the baldchin groper stock (C3×L1= LOW).

- WCRLMF fishers retain relatively small quantities of baldchin groper while accessing the Offshore Crustacean Resource (estimated 13 kg in 2020/21). This is very low compared to the total WCB catch of this species retained by all sectors (~60 t in 2021).
- No catches of baldchin groper have been recorded by other offshore crustacean fisheries.
- The current risk to the WCB baldchin groper stock from all fishing has been assessed by DPIRD as HIGH (Fisher *et al.* in prep).
- The workshop concluded that there was a Remote likelihood that catches of baldchin groper by the WCRLMF taken while accessing the Resource will have a High impact on the WCB baldchin groper stock.

8.1.12 Other retained fish species

Risk Rating: Impact of harvesting the Resource on stocks of other fish species (C1×L1= NEGLIGIBLE).

- Catches of other fish species by offshore crustacean fisheries are very low (e.g. 8 kg of dhufish in 2020/21). Such low catches were not expected to have any measurable impacts on these stocks.

8.2 Bycatch (discarded) species

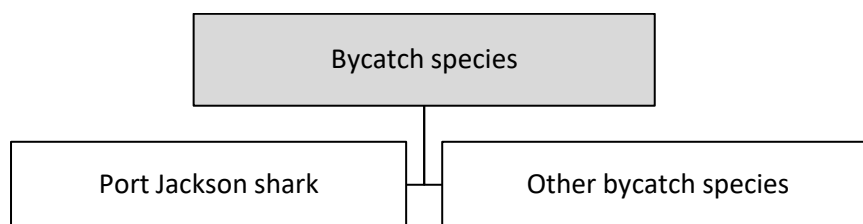

8.2.1 *Port Jackson shark (Heterodontus portusjacksoni)*

Risk Rating: Impact of harvesting the Resource on the Port Jackson shark stock (C2×L1= NEGLIGIBLE).

- Port Jackson sharks captured by offshore crustacean fisheries are not retained.
- The catch of Port Jackson sharks by offshore crustacean fisheries is relatively low compared to the total catch of the stock. This stock is caught by fisheries in WA, SA and Victoria. The total WA catch (all fisheries) is estimated to be 10-15 t per year.
- In all fisheries, Port Jackson sharks are almost always released. Studies suggest they have high post-release survival from a range of fishing gear types. The stock has been assessed as 'sustainable' (Simpfendorfer *et al.* 2019).
- The workshop concluded that there was a Remote likelihood that catches of Port Jackson sharks taken while accessing the Resource will have a Moderate impact on the Port Jackson shark stock.

8.2.2 *Other bycatch species*

Risk Rating: Impact of harvesting the Resource on stocks of other discarded species (C1×L1= NEGLIGIBLE).

- A small number of other teleost, shark and invertebrate species are taken as bycatch while accessing the Offshore Crustacean Resource. These are captured in very low quantities (<20 individuals of each species per year).
- The number of individuals taken is low compared to the likely population size of each species. This level of impact was not expected to have any measurable impact on each stock

8.3 ETP species

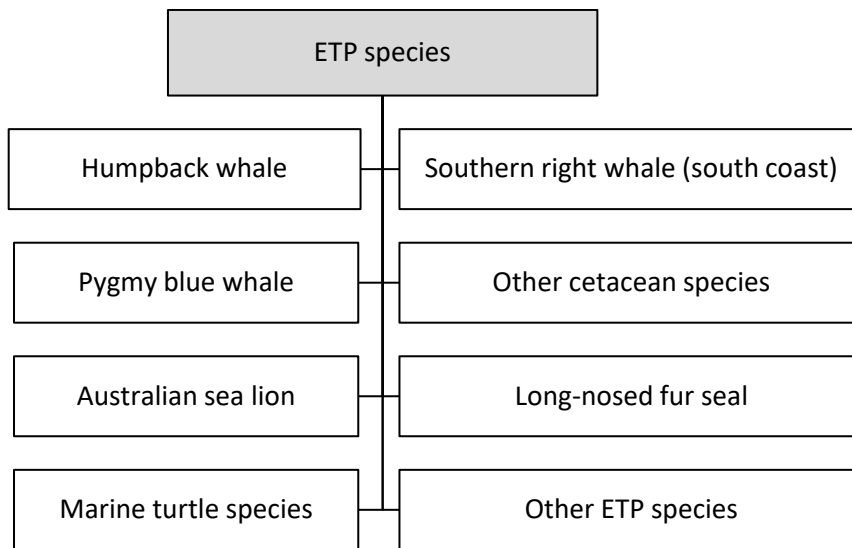

8.3.1 Humpback whale (*Megaptera novaeangliae*)

Risk Rating: Impact of harvesting the Resource on the Humpback whale population (C2xL2= LOW).

- Humpback whale population which occurs along the WA coast is estimated to be >30,000 individuals and regarded as fully recovered. The large number of individuals (compared to other whale species) increases the chance of interactions with fishing gear.
- There have been 3 entanglements with the WCDSCMF since 1990 (in 2014, 2020 and 2021). The 2021 entanglement resulted in a mortality. The WCDSCMF has <100 vertical lines in the water at any given time, which is relatively low, although the 'long-line' configuration of gear used is more likely to entangle than individually-set pots.
- There have been 2 entanglements with the SCCMF since 1990 (in 2015 and 2018).
- The WCRLMF accesses the Offshore Crustacean Resource during December-January, when humpback whales are not present along the west coast. Therefore interactions with the WCRLMF while it accesses the Resource are not expected to occur.
- A number of mitigation measures were introduced in the WCRLMF in 2014 (weighted lines (which reduce the amount of slack rope), reduced rope length and number of floats) which have been effective in reducing likelihood of entanglement. These measures have been adopted voluntarily by the WCDSCMF and recently mandated in the SCCMF as part of new management arrangements.
- The workshop concluded that it was likely that a few individuals would interact with offshore crustacean fisheries, and potentially become entangled, in the next 5 years. Assuming this level of interaction, a Minor impact to the population was considered to be Likely. A Moderate impact to the population was considered to be Unlikely.

8.3.2 Southern right whale (*Eubalaena australis*)

Risk Rating: Impact of the SCCMF on the southern right whale population (C3×L1= LOW).

Risk Rating: Impact of the WCRLMF (while accessing the Resource) and the WCDSCMF on the southern right whale population (C1×L1= NEGLIGIBLE).

- The western Australian population of southern right whale occurs in WA and SA waters.
- Population size is uncertain. Recent estimates are approximately 2,500 to 3,000 individuals, although estimates are highly variable between surveys. Similarly, the long-term population trend is uncertain but available evidence suggests around 5% growth per year.
- The southern right whale is listed as “Vulnerable” under the WA BC Act and “Endangered” under the Commonwealth EPBC Act.
- Since 1990 there has been 1 recorded entanglement of a southern right whale in WA. This occurred in the WCRLMF, but not while accessing the Resource. The low number of recorded interactions may in part reflect the low population size, compared to humpback whales. As the southern right whale population grows, the number of fishery interactions may increase in future.
- Mitigation measures introduced in offshore crustacean fisheries to reduce the likelihood of humpback whale entanglements are expected to be similarly effective for southern right whales.
- The WCRLMF accesses the Offshore Crustacean Resource during December-January, when southern right whales are not present along the west coast. Therefore interactions with the WCRLMF while it accesses the Resource are not expected to occur.
- The WCDSCMF mainly operates in offshore waters in the northern part of the West Coast Bioregion and in the southern Gascoyne Coast Bioregion, resulting in low spatial overlap with migrating southern right whales in coastal waters.
- Under new management arrangements, the SSCMF has the potential to fish all year round. However, the gear configuration is unfavourable for winter conditions, so the amount of winter fishing is expected to remain low. This means the temporal overlap with southern right whales (which are present in May-October) is expected to remain low.
- On the south coast, recreational harvesting of SRL is mainly undertaken by diving, and so there is minimal risk of entanglement with recreational fishing gear.
- The workshop concluded that there was a Remote likelihood that interactions with the SCCMF over the next 5 years would have a High impact (i.e. affect population recovery).
- The WCRLMF (while accessing the Resource) and the WCDSCMF were not expected to have any impact on the population over the next 5 years.

8.3.3 Pygmy blue whale (*Balenoptera musculus brevicauda*)

Risk Rating: Impact of harvesting the Resource on the pygmy blue whale population (C3×L1= LOW).

- The pygmy blue whale is listed as “Endangered” under the WA BC Act and the Commonwealth EPBC Act.
- Pygmy blue whales occur off WA during warmer months, in shelf and slope waters.
- Since 1990 there has been zero recorded entanglements of pygmy blue whales in WA.
- Mitigation measures introduced in offshore crustacean fisheries to reduce the likelihood of humpback whale entanglements are expected to be similarly effective for pygmy blue whales.
- Given the current population status, and uncertainties about the population, it was acknowledged that even a low level of interaction could potentially affect population recovery.
- The workshop concluded that there was a Remote likelihood that interactions with offshore crustacean fisheries over the next 5 years would have a High impact (i.e. affect population recovery).

8.3.4 Other cetacean species

Risk Rating: Impact of harvesting the Resource on the populations of other cetacean species (C1×L1= NEGLIGIBLE).

- Since 1990, there have been zero recorded entanglements of other cetacean species in WA.
- Numerous observations of dolphins have been recorded in offshore crustacean fishery logbooks, but these do not constitute negative interactions. Dolphin entanglements in pot-based fishing gear is extremely rare.
- The offshore crustacean fisheries were not expected to have any impact on populations of other cetacean species over the next 5 years.

8.3.5 Australian sea lion (*Neophoca cinerea*)

Risk Rating: Impact of harvesting the Resource on the population of Australian sea lion (ASL) (C4×L1= LOW).

- The ASL is listed as “Vulnerable” under the WA BC Act and “Endangered” under the Commonwealth EPBC Act. About 34 breeding colonies occur in WA waters; all are small, producing <100 pups per year.
- Historically, ASL pup mortalities occurred in lobster pots in inshore waters, but this risk was mitigated in the WCRLMF by the installation of Sea Lion Exclusion Devices (SLEDs) on all pots.
- No ASL interactions have been recorded in offshore crustacean fisheries.
- ASL interactions with offshore crustacean fisheries are not expected to occur because fishing occurs offshore and in deep water, beyond the foraging range of ASL pups. The exception is fishing for SRL along the south coast, which occurs in both offshore and inshore waters.

- 'SLED zones' have been implemented around all known ASL colonies that occur within the SCCMF area. The use of SLEDs is compulsory within these zones. In practise, it is inconvenient for fishers to remove the SLEDs from pots so they typically remain on pots when they are used in other areas too.
- The workshop noted that any level of additional mortality has the potential to affect the recovery of a small ASL colony. However, given the mitigation measures that are in place in the SCCMF, it was concluded that the likelihood of a Major impact on a colony was Remote.

8.3.6 Long-nosed fur seal (*Arctocephalus forsteri*)

Risk Rating: Impact of the harvesting the Resource on the populations of long-nosed fur seal (LNFS) (C1×L1= NEGLIGIBLE).

- In contrast to ASLs, there have been zero recorded interactions with the LNFS in offshore crustacean fisheries or other pot-based fisheries. This is likely due to different foraging strategies - the LNFS often feeds in the water column whereas the ASL is a benthic feeder.
- The use of SLEDs in pots would mitigate any risk of LNFS pup mortality.
- Currently, there are no conservation concerns for the LNFS in WA.
- The offshore crustacean fisheries were not expected to have any impact on breeding colonies of LNFS over the next 5 years.

8.3.7 Marine turtles

Risk Rating: Impact of harvesting the Resource on the leatherback turtle population (C2×L1= NEGLIGIBLE).

Risk Rating: Impact of harvesting the Resource on the populations of other marine turtle species (C1×L1= NEGLIGIBLE).

- Unlike other marine turtle species, which are restricted to tropical/sub-tropical waters, the leatherback turtle (*Dermochelys coriacea*) also forages in cold water areas. Hence, offshore crustacean fisheries significantly overlap with the leatherback turtle but have much lower overlap with other marine turtle species.
- The leatherback turtle is listed as "Vulnerable" under the WA BC Act and "Endangered" under the EPBC Act.
- There have been zero recorded interactions with SCCMF and WCDSCMF. There have been a small number of turtle entanglements recorded in the WCRLMF, but no mortalities.
- The WCDSCMF has <100 vertical lines in the water at any given time, which presents limited opportunity for turtle entanglements.
- The workshop concluded that there was a Remote likelihood that interactions with offshore crustacean fisheries would have a Moderate impact on the leatherback turtle population.
- The offshore crustacean fisheries were not expected to have any impact on populations of other marine turtle species.

8.3.8 Other ETP species

Risk Rating: Impact of harvesting the Resource on the populations of other cetacean species (C1xL1= NEGLIGIBLE).

- Various other ETP species (including syngnathids, sea birds, sea snakes, elasmobranchs) overlap with offshore crustacean fisheries. However, there are zero recorded interactions with these species.
- The offshore crustacean fisheries were not expected to have a measurable impact on any populations of other ETP species.

8.4 Habitats

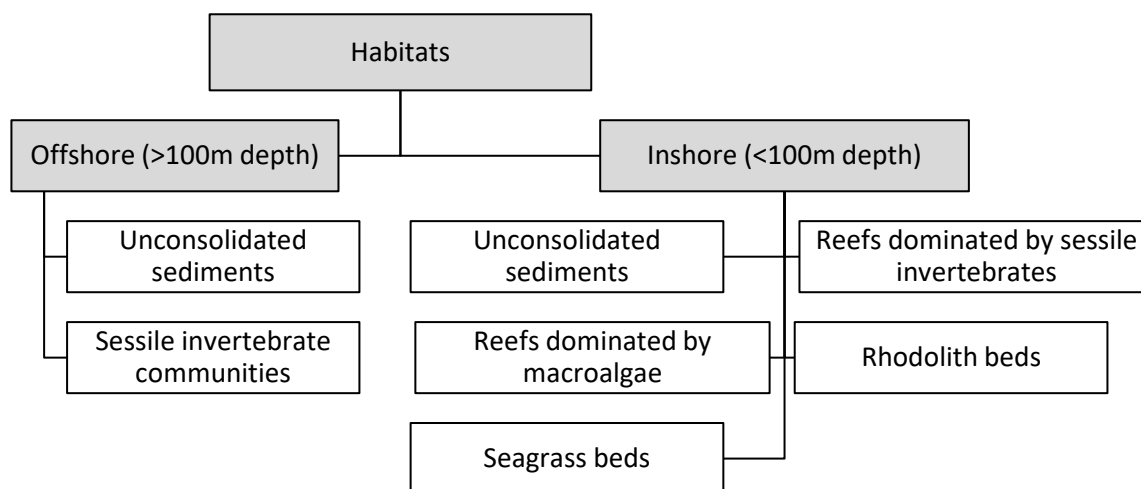

NOTES: There is limited information about the distribution and types of benthic habitats, particularly in offshore waters (i.e. outer shelf and slope). Published studies indicate offshore substrates are mostly fine-grained (i.e. predominantly mud, sometimes mixed with sand and/or gravel), and that there are two broad habitat types in offshore crustacean fishing areas: i) bare mud and ii) low-density sessile invertebrate communities.

Fishery interactions with inshore habitats are restricted to the south coast, where the SCCMF targets SRL in inshore waters.

To assist the workshop in assessing risk to habitats, the annual benthic 'footprint' of the fisheries was estimated from the number of potlifts, assuming an average pot has a benthic footprint of 1 m². For example, 100,000 pot lifts would equate to a total impacted area of 0.10 km² of benthic habitat. The WCDSCMF Harvest strategy stipulates an annual Threshold level of ≤169,000 potlifts (= 0.17 km²). In recent years the SCCMF has typically recorded a total of 200,000 to 300,000 potlifts per year (= 0.20 to 0.30 km²), spread across 4 zones (see Figure 4-18). DPIRD camera-based surveys indicate that ropes typically remain suspended above the pots, and so do not contribute to the benthic footprint because they do not make contact with the bottom.

8.4.1 Offshore unconsolidated sediments

Risk Rating: Impact of harvesting the Resource on offshore habitats comprised of unconsolidated sediments (C1×L1= NEGLIGIBLE).

- DPIRD recently commenced camera-based surveys of offshore habitats on WCDSCMF fishing grounds to improve understanding of the main habitat types. To date this work suggests 'bare mud' (without sessile invertebrates) is the most common offshore habitat type on fishing grounds. It is assumed that bare mud is also the main offshore habitat type in the SCCMF.
- Bare mud habitats may contain burrowing infauna, which are not expected to be significantly affected by a pot landing on the surface of the mud.
- The offshore crustacean fisheries were not expected to have a measurable impact on offshore habitats comprised of unconsolidated sediments.

8.4.2 Offshore sessile invertebrate communities

Risk Rating: Impact of harvesting the Resource on offshore habitats comprised of benthic sessile invertebrate communities (C2xL1= NEGLIGIBLE).

- Available evidence suggests benthic sessile invertebrate communities on the fishing grounds typically comprise low densities of sessile, filter-feeding organisms growing on the sea floor.
- The workshop noted a high level of uncertainty when scoring this issue. The species composition and spatial extent of the offshore sessile invertebrate communities that interact with these fisheries is not known. Although it was considered likely that annual effort was typically dispersed over a wide area (resulting in minimal impact), it was possible that some areas experienced more concentrated effort (resulting in a localised impact).
- Sessile invertebrate species in deep waters are likely to have slow growth and low productivity due to the cold, nutrient-poor waters in which they live, and so are likely to be slow to regrow if damaged by fish gear.
- When offshore, particularly when targeting crystal crabs, fishers actively seek out featureless bottoms and try to avoid setting pots on higher relief/complex bottoms (e.g. canyons), which contain higher densities of sessile invertebrates, due to the chance of snagging gear.
- The workshop concluded that there was a Remote likelihood that interactions with offshore crustacean fisheries would have a Moderate impact on offshore communities of sessile invertebrates.

8.4.3 Inshore unconsolidated sediments

Risk Rating: Impact of the SCCMF on inshore habitats comprised of unconsolidated sediments (C1xL1= NEGLIGIBLE).

- Unconsolidated sediments in inshore areas along the south coast are predominantly sand.
- Bare sand habitats are naturally dynamic environments, and so habitat structure and infauna are likely to be highly resilient to any short term (over-night) disturbance by a lobster pot.
- The SCCMF was not expected to have a measurable impact on bare sand habitats.

8.4.4 Inshore reefs dominated by macroalgae communities

Risk Rating: Impact of the SCCMF on inshore reefs dominated by macroalgae communities (C2xL1= NEGLIGIBLE).

- Lobster are strongly associated with reefs and so pots are likely to be set in this habitat. There is potential for a concentration of effort around certain reefs, i.e. revisiting these sites, resulting in localised impacts. However, individual fishers do not typically go over the same ground within a season and will often 'rest' an area in alternate years.
- Short term (over-night) setting of lobster pots on macroalgae would be unlikely to damage the macroalgae. Macroalgae is relatively fast-growing and likely to regrow relatively quickly if damaged by a pot.
- Recreational fishing for SRL mainly involves diving (not potting) and so is not expected to impact on reef habitats.

- Given the inherent resilience of macroalgae, the workshop concluded that the SCCMF was Unlikely to have a Moderate impact on reefs dominated by macroalgae communities.

8.4.5 *Inshore reefs dominated by sessile invertebrate communities*

Risk Rating: Impact of the SCCMF on inshore reefs dominated by sessile invertebrate communities (C2×L2= LOW).

- Lobster are strongly associated with reefs and so pots are likely to be set in this habitat. There is potential for a concentration of effort to occur around certain reefs, i.e. revisiting these sites, resulting in localised impacts. However, individual fishers do not typically go over the same ground within a season and will often 'rest' an area in alternate years.
- Compared to macroalgae, sessile invertebrates are expected to be less resilient to interactions with fishing gear – they are more likely to be damaged if a pot is set on them and be slower growing with longer recovery times if damaged.
- The workshop concluded it was Possible that the SCCMF could have measurable localised impacts (i.e., a Minor consequence) on inshore reefs dominated by sessile invertebrate communities, but that a Major impact on this habitat type was Unlikely.

8.4.6 *Rhodolith beds*

Risk Rating: Impact of the SCCMF on rhodolith beds (C1×L2= NEGLIGIBLE).

- Rhodoliths are free-living 'balls' of calcareous red algae. Rhodolith beds are biodiverse because they provide structure/substrate for many other organisms. Rhodoliths themselves are unlikely to be damaged by a lobster pot, but some organisms growing on them may be damaged.
- Lobster may occur in rhodolith beds and so pots may be set here.
- Given the footprint of the fishery, the workshop concluded that the SCCMF was Unlikely to have a measurable impact on rhodolith beds.

8.4.7 *Seagrass beds*

Risk Rating: Impact of the SCCMF on seagrass habitats (C1×L1= NEGLIGIBLE).

- Lobsters are uncommon in seagrass habitat and so pots are not typically set on seagrass.
- Research has shown that over-night setting of lobster pots on seagrass does not damage the seagrass.
- The SCCMF was not expected to have a measurable impact on seagrass habitats.

8.5 Ecosystem structure

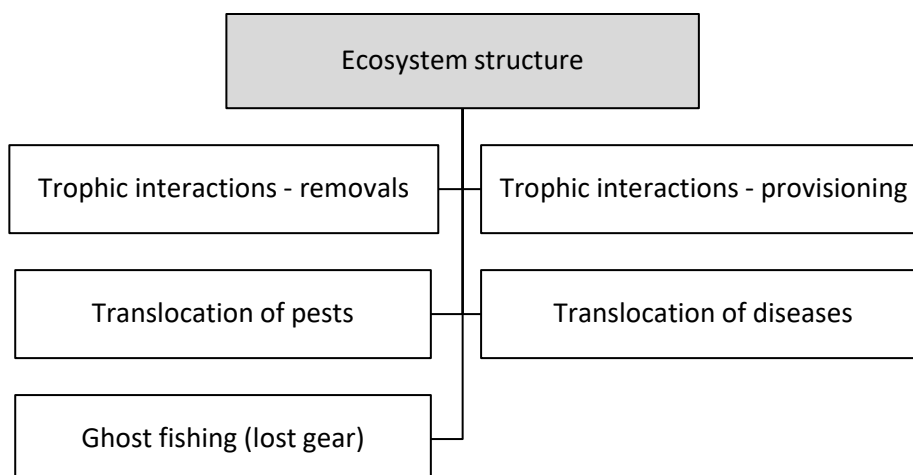

8.5.1 *Trophic interactions - removals*

Risk Rating: Trophic impact of biomass removals by offshore crustacean fisheries (C2xL1= NEGLIGIBLE).

- On the west coast, the total biomass removed (due to harvesting of the 4 target species) is currently about 155 t per year. On the south coast, the TACCs for the SCCMF allow for a total biomass of about 62 t to potentially be removed per year.
- These removals are spread over a wide area in each region.
- There is no evidence of any structural or functional change in the ecosystem after several decades of biomass removals by offshore crustacean fishing.
- Fishery management is designed to leave a substantial unfished biomass of each stock in the water, which continues to perform trophic functions.
- Offshore crustaceans are not believed to be 'keystone' species in the ecosystem. Other species in the ecosystem also perform similar trophic roles. Deep sea crabs are opportunistic predators and scavengers, while SRL is an opportunistic omnivore. There are no known predators of deep sea crabs, while SLR has multiple known predators (e.g. octopus, sharks, large fish, marine mammals) although none are dependent (obligate) on SLR.
- Fishers continually move around to maintain their catch rate of deep sea crabs at an economic level, they do not try to completely deplete an area. There will likely be a residual population left behind after fishing.
- When targeting SRL on the south coast, individual fishers do not typically go over the same ground within a season and will often 'rest' an area in alternate years.
- The workshop concluded that there was a Remote likelihood of a Moderate trophic impact due to biomass removals by offshore crustacean fisheries.

8.5.2 *Trophic interactions - provisioning*

Risk Rating: Trophic impact of the addition of bait to the ecosystem by offshore crustacean fisheries (C2xL1= NEGLIGIBLE).

- The deep sea is a low nutrient environment, so there is potential for an impact on the food web due to the addition of bait. The addition of bait is less likely to have an impact in inshore waters, which are naturally more productive.
- In 2021, an estimated total of 150 t of bait was used on the west coast and ~21 t used on the south coast by offshore crustacean fisheries. Note - south coast effort was low in 2021, and so bait use could be slightly higher in future if effort rises.
- For context, 150 t is approximately the weight of 5 adult humpback whales.
- The bait is predominantly frozen fish imported from New Zealand.
- Some of the bait does not remain in the environment because it is consumed by the target species which are then captured.
- The bait is dispersed over a large area.
- The workshop concluded that there was a Remote likelihood of a Moderate trophic impact due to the addition of bait to the ecosystem by offshore crustacean fisheries.

8.5.3 Translocation of pests

Risk Rating: Impact of translocation of pest species by offshore crustacean fisheries (C1×L1= NEGLIGIBLE).

- Dr. S. Bridgwood (DPIRD, Biosecurity) advised that several factors greatly mitigate the pest translocation risk in offshore crustacean fisheries: offshore fishing is below depth tolerance of most 'pests of concern'; absence of offshore infrastructure/surfaces that host pests; limited number of participating vessels; limited vessel movements between ports.
- Further mitigation is achieved through regular hull maintenance, including maintaining the biofouling level to a slime layer and appropriate application of anti-fouling coating. Most vessels are expected to do this type of maintenance because it reduces running costs.
- Offshore crustacean fisheries were considered to have a Remote likelihood of translocating pest species.

8.5.4 Translocation of diseases

Risk Rating: Impact of translocation of diseases by offshore crustacean fisheries (C3×L2= MEDIUM).

- Frozen, wild caught fish imported from New Zealand (NZ) represents >80% by weight of bait used by offshore crustacean fisheries.
- Imported bait species are mainly blue mackerel, hoki (= blue grenadier), and pilchards. Separate breeding stocks of the same species occur in WA waters.
- Many potential pathogens/parasites are destroyed by freezing. Fish pathogens surviving freezing are likely to be viral or bacterial.
- Viral and bacterial diseases of fish are very unlikely to switch to a new crustacean host, and so the bait poses minimal risk for local crustaceans. The main risk is to local fish populations (particularly those of same/similar species).
- There are no known diseases that are of concern to Australia in NZ baitfish species.

- Risk posed by unknown diseases are difficult to assess – biosecurity risk assessments would normally consider availability of susceptible hosts, mechanisms and rate of transmission in host populations, etc, but these factors are unknown.
- Early detection and eradication of a translocated disease would be unlikely.
- Direct ingestion of bait is the most likely transmission route. Use of pots may limit (but not prevent) direct ingestion by fish. If bait is mostly consumed by crabs and the pots are dispersed, this should dilute the dose (reducing risk of disease) for fish consuming any uneaten infected bait.
- The known ecological consequences of the mass mortality of Australian pilchards (*Sardinops sagax neopilchardus*) in 1995 and 1998–99 due to the translocation of Pilchard Herpesvirus in imported bait was considered by the workshop in scoring this issue.
- The workshop concluded that there was an Unlikely likelihood of a High ecological impact due to the translocation of disease via imported bait by offshore crustacean fisheries.

8.5.5 Ghost fishing (lost gear)

Risk Rating: Impact of ghost fishing by lost gear from offshore crustacean fisheries (C1×L2= NEGLIGIBLE).

- Numerous factors greatly mitigate the risk of ghost fishing in these fisheries:
- Mandatory escape gaps are required in all pots.
- Mandatory reporting of any lost commercial gear for SCCMF and WCDSCMF.
- Recreational fishing for SRL mainly involves diving not potting.
- Pots without bait are much less likely to attract species.
- There is a financial incentive to recover recreational and commercial gear.
- Long-lined gear is recoverable due to the two vertical lines (if one rope breaks, the other can be still used).
- Wood/metal in some pots breaks down over time. However, crystal crab pots are plastic and do not break down. The introduction of a biodegradable pin in plastic traps is currently under consideration - that would cause them to open up after a period time.
- An estimated 80-100 plastic pots are lost per year in the WCDSCMF. Assuming the plastic pots do not break down, these would accumulate over time. These are unlikely to ghost fish because of the absence of bait, but they may form artificial habitat for some organisms.
- The workshop concluded that there was an Unlikely likelihood of a Minor ecological impact due ghost fishing by lost gear from offshore crustacean fisheries.

8.6 Broader environment

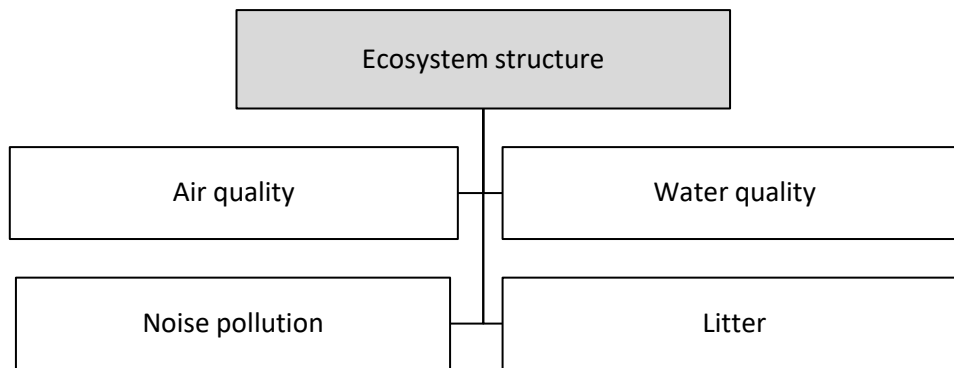

8.6.1 Air quality

Risk Rating: Impact of harvesting the Resource on air quality (C1×L1= NEGLIGIBLE).

- There was 480 fishing days by the WCDSCMF in 2021, ~215 fishing days by the SCCMF in 2021/22, and ~157 fishing days (for offshore crustaceans) by the WCRLMF in 2021.
- The impact of exhaust fumes generated by this fishing activity spread across the year and over a large area is expected to be undetectable.

8.6.2 Water quality

Risk Rating: Impact of harvesting the Resource on water quality (C1×L1= NEGLIGIBLE).

- The impact of any oil or fuel spills during this fishing activity spread across the year and over a large area is expected to be undetectable.

8.6.3 Noise pollution

Risk Rating: Impact of harvesting the Resource on environmental noise levels (C1×L1= NEGLIGIBLE).

- The impact of noise generated by this fishing activity spread across the year and over a large area is not expected to have any measurable ecological consequence.

8.6.4 Litter

Risk Rating: Impact of harvesting the Resource on environmental litter levels (C1×L3= LOW).

- There is a public perception of littering by the WCRLMF due to ropes and floats washing up on beaches (which are not necessarily from the WCRLMF). However, a recent study found the rate of commercial gear loss by this fishery was low by global standards (Bornt *et al.* in press).
- Recreational fishing for SRL mainly involves diving not potting, reducing the opportunities for lost gear.
- An estimated 80-100 plastic pots are lost per year in the WCDSCMF. Assuming the plastic pots do not break down, these would accumulate over time.
- The workshop concluded that the impact of lost plastic pots was a low risk to the environment, but noted that it was socially unacceptable.

9.0 References

- Bannister J, Kemper CM, Warneke RM. 1996. The action plan for Australian cetaceans. Australian Nature Conservation Agency. Wildlife Australia, Endangered Species Program, Project. 1996(390).
- Bornt K, How J, de Lestang S, Linge K, Hovey R, Langlois T. 2023. Plastic gear loss estimates from a major Australian pot fishery. *ICES Journal of Marine Science* 80:158-172. <https://doi.org/10.1093/icesjms/fsac222>
- Braccini M, Van Rijn J, Frick L. 2012. High Post-Capture Survival for Sharks, Rays and Chimaeras Discarded in the Main Shark Fishery of Australia. *PLoS One* 7: e32547 <https://doi.org/10.1371/journal.pone.0032547>
- Bray, D.J. 2020a. *Meuschenia hippocrepis* in Fishes of Australia, accessed 21 Nov 2022, <https://fishesofaustralia.net.au/home/species/807>
- Bray, D.J. 2020b. *Nelusetta ayraud* in Fishes of Australia, accessed 21 Nov 2022, <https://fishesofaustralia.net.au/home/species/811>
- Bray DJ. 2020c. *Epinephelides armatus* in Fishes of Australia, accessed 21 Nov 2022, <https://fishesofaustralia.net.au/home/species/4375>
- Bray DJ. 2020d. *Othos dentex* in Fishes of Australia, accessed 21 Nov 2022, <https://fishesofaustralia.net.au/home/species/4383>
- Briceno F, Linnane A, Quiroz J, Gardner C, Pecl G. 2015. Predation Risk Within Fishing Gear and Implications for South Australian Rock Lobster Fisheries. *PLOS ONE* 10(10) <https://doi.org/10.1371/journal.pone.0139816>
- Bridgwood S, McDonald J. 2014. Likelihood analysis of the introduction of marine pests to Western Australian ports via commercial vessels. Department of Fisheries, North Beach, Western Australia. http://www.fish.wa.gov.au/Documents/research_reports/frr259.pdf
- Bruce BD, Griffin DA, Bradford RW. 2007. Larval transport and recruitment processes of southern rock lobster. Hobart, CSIRO Marine and Atmospheric Research.
- Bunce A, Norman FI. 2000. Changes in the diet of the Australasian gannet (*Morus serrator*) in response to the 1998 mortality of pilchards (*Sardinops sagax*). *Marine and Freshwater Research* 51:349-353. <https://doi.org/10.1071/MF99133>
- Campbell R, Holley D, Christianopoulos D, Caputi N, Gales N. 2008. Mitigation of incidental mortality of Australian sea lions in the west coast rock lobster fishery. *Endangered Species Research*. 5:345-58. <https://doi.org/10.3354/esr00155>
- Carroll EL, Patenaude N, Childerhouse SJ, Kraus SD, Fewster RM, Baker CS. 2011. Abundance of the New Zealand subantarctic southern right whale population estimated from photo-identification and genotype mark-recapture. *Marine Biology*.158:2565-75. <https://doi.org/10.1007/s00227-011-1757-9>
- Chiaradia A, Forero MG, Hobson KA, Cullen JM. 2010. Changes in diet and trophic position of a top predator 10 years after a mass mortality of a key prey. *ICES Journal of Marine Science* 67:1710-1720. <https://doi.org/10.1093/icesjms/fsq067>
- Commonwealth of Australia (CoA). 2012. Species group report card —cetaceans. Supporting the marine bioregional plan for the South-west Marine Region. <https://www.dcceew.gov.au/environment/marine/marine-bioregional-plans/south-west>
- Commonwealth of Australia (CoA). 2015. Conservation Management Plan for the Blue Whale—A Recovery Plan under the Environment Protection and Biodiversity Conservation Act 1999, Commonwealth of Australia. <https://www.dcceew.gov.au/sites/default/files/documents/blue-whale-conservation-management-plan.pdf>

- Dann P, Norman FI, Cullen JM, Neira FJ, Chiaradia A. 2000. Mortality and breeding failure of little penguins, *Eudyptula minor*, in Victoria, 1995–96, following a widespread mortality of pilchard, *Sardinops sagax*. *Marine and Freshwater Research* 51:355-362. <https://doi.org/10.1071/MF99114>
- Davie PJF, Ng PKL, Dawson EW. 2007. A new species of deep-sea crab of the genus *Chaceon* Manning & Holthuis, 1989 (Crustacea: Decapoda: Brachyura: Geryonidae) from Western Australia. *Zootaxa* 62:51–62.
- Department of Agriculture, Water and the Environment (DAWE). 2022. Listing Advice Megaptera novaeangliae Humpback Whale. Canberra: Department of Agriculture, Water and the Environment. <http://www.environment.gov.au/biodiversity/threatened/species/pubs/38-listing-advice-26022022.pdf>
- Day J, Clark J, Williamson J, Brown C, Gillings M. 2019. Population genetic analyses reveal female reproductive philopatry in the oviparous Port Jackson shark. *Marine and Freshwater Research* 70:986-994. <https://doi.org/10.1071/MF18255>
- de Lestang S, Caputi N, How J. 2016. Resource Assessment Report: Western Rock Lobster Resource of Western Australia. Page Western Australian Marine Stewardship Council Report Series No. 9. http://www.fish.wa.gov.au/Documents/wamsc_reports/wamsc_report_no_9.pdf
- de Lestang S, Caputi N, How JR, Melville-Smith R, Thomson A, Stephenson P. 2012. Stock assessment for the west coast rock lobster fishery. Page Fisheries Research Report. http://www.fish.wa.gov.au/Documents/research_reports/frr217.pdf.
- de Lestang S, Rossbach M, Orne L, Baudains G. 2021. West coast rock lobster resource status report 2021. In: Status Reports of the Fisheries and Aquatic Resources of Western Australia 2020/21: The State of the Fisheries. Newman SJ, Wise BS, Santoro KG, Gaughan DJ (eds). p 28–34.
- Department of Fisheries. 2002. Policy for the Implementation of Ecologically Sustainable Development for Fisheries and Aquaculture Within Western Australia. Fisheries Management Paper 157.
- Department of Primary Industries and Regional Development (DPIRD). 2020. West Coast Deep Sea Crustacean Resource Harvest Strategy. Department of Primary Industries and Regional Development, Perth. http://www.fish.wa.gov.au/Documents/management_papers/fmp302.pdf.
- Di Franco E., Pierson P., Di Iorio L., Calò A., Cottalorda J.M., Derijard B., Di Franco, A., Galvé A., Guibolini M., Lebrun J. and Micheli F. 2020. Effects of marine noise pollution on Mediterranean fishes and invertebrates: A review. *Marine Pollution Bulletin* 159:111450. <https://doi.org/10.1016/j.marpolbul.2020.111450>
- Diggles BK. 2011. Risk Analysis: Aquatic Animal Diseases Associated with Domestic Bait Translocation. FRDC Project No. 2009/072, Final Report July 2011. DigsFish Services.
- Domingos S, Athie A, Rossi-Wongtschowski C. 2007. Diet of *Chaceon notialis* (Decapoda, Brachyura) Off the Coast of Rio Grande, RS, Brazil. *Brazilian Journal of Oceanography* 55:327-329.
- Department of Sustainability, Environment, Water, Population and Communities (DSEWPAC). 2012. Conservation Management Plan for the Southern Right Whale A Recovery Plan under the Environment Protection and Biodiversity Conservation Act 1999 2011–2021. <https://www.dcceew.gov.au/sites/default/files/documents/e-australis-2011-2021.pdf>
- Department of Sustainability, Environment, Water, Population and Communities (DSEWPAC). 2013a. Recovery Plan for the Australian Sea-lion (*Neophoca cinerea*). Commonwealth of Australia. <https://www.environment.gov.au/biodiversity/threatened/recoveryplans/recovery-plan-australian-sea-lion-neophoca-cinerea-2013>
- Duarte CM, Chapuis L, Collin SP, Costa DP, Devassy RP, Eguiluz VM, Erbe C, Gordon TA, Halpern BS, Harding HR, Havlik MN. 2021. The soundscape of the Anthropocene ocean. *Science* 371(6529):eaba4658. <https://doi.org/10.1126/science.aba4658>
- Erbe C, Verma A, McCauley R, Gavrillov A, Parnum I. 2015 The marine soundscape of the Perth Canyon. *Progress in Oceanography* 137:38–51. <https://doi.org/10.1016/j.pocean.2015.05.015>

- Erbe C, Dunlop R, Dolman S. 2018. Effects of noise on marine mammals. In: Effects of anthropogenic noise on animals. pp. 277-309. Springer, New York, NY. https://doi.org/10.1007/978-1-4939-8574-6_10
- Evans K, Bax N, Smith D. 2016. Marine environment: Anthropogenic noise. In: Australia state of the environment 2016. Australian Government Department of the Environment and Energy, Canberra.
- Fairclough DV, Hesp SA, Denham A, Fisher EA, Marks R, Ryan KL, Lek E, Allen R, Crisafulli BM. 2021. 2021 assessment of the status of the West Coast Demersal Scalefish Resource. Fisheries Research Report No. 316. Department of Primary Industries and Regional Development, Western Australia. 158 pp. https://library.dpird.wa.gov.au/cgi/viewcontent.cgi?article=1108&context=fr_rr
- Farrelly C, Ahyong S. 2019. Deepwater Decapod, Stomatopod and Lophogastrid Crustacea from Eastern Australia and the Great Australian Bight Collected in 2015-2017: Preliminary Identifications of 191 Species. Museum Victoria Science Reports 21:1-97. <https://doi.org/10.24199/j.mvsr.2019.21>
- Fisher ED, Fairclough D, Walters S. (in prep.) West Coast Demersal Scalefish Resource Status Report 2022. (in) Status Reports of the Fisheries and Aquatic Resources of Western Australia 2021/22: The State of the Fisheries (eds. Newman SJ, Wise BS, Santoro KG, Gaughan DJ). Department of Primary Industries and Regional Development, Western Australia.
- Fletcher W. 2005. Application of qualitative risk assessment methodology to prioritise issues for fisheries management. ICES Journal of Marine Research 62:1576-1587. <https://doi.org/10.1016/j.icesjms.2005.06.005>
- Fletcher WJ. 2015. Review and refinement of an existing qualitative risk assessment method for application within an ecosystem-based fisheries management framework. ICES Journal of Marine Science 72:1043-1056. <https://doi.org/10.1093/icesjms/fsu142>
- Fletcher W, Chesson J, Sainsbury K, Fisher M, Hundloe T, Whitworth B. 2002. Reporting on Ecologically Sustainable Development: A "how to guide" for fisheries in Australia. Canberra, Australia. 120 pp.
- Fletcher, W.J., Gaughan, D.J., Metcalf, S.J., Shaw, J. (2012). Using a regional level, risk based framework to cost effectively implement Ecosystem Based Fisheries Management (EBFM). In: Global progress on Ecosystem-Based Fisheries Management (G.H. Kruse, H.I. Browman, K.L. Cochrane, D. Evans, G.S. Jamieson, P.A. Livingston, D. Woodby, C. Ik Zhang eds.). Fairbanks: Alaska Sea Grant College Programme pp. 129-146.
- Fletcher WJ, Shaw J, Metcalf SJ, Gaughan DJ. 2010. An ecosystem-based fisheries management framework: the efficient, regional-level planning tool for management agencies. Marine Policy 34, 1226-1238. <https://doi.org/10.1016/j.marpol.2010.04.007>
- Fletcher WJ, Wise BS, Joll LM, Hall NG, Fisher EA, Harry AV, Fairclough DV, Gaughan DJ, Travaille K, Molony BW, Kangas M. 2016. Refinements to harvest strategies to enable effective implementation of Ecosystem Based Fisheries Management for the multi-sector, multi-species fisheries of Western Australia. Fisheries Research 183:594-608. <https://doi.org/10.1016/j.fishres.2016.04.014>
- French B, Potter IC, Hesp SA, Coulson PG, Hall NG. 2014. Biology of the harlequin fish *Othos dentex* (Serranidae), with particular emphasis on sexual pattern and other reproductive characteristics. Journal of Fish Biology 84:106-132. <https://doi.org/10.1111/jfb.12258>
- Frick L, Reina R, Walker T. 2009. The physiological response of Port Jackson sharks and Australian swellsharks to sedation, gillnet capture, and repeated sampling in captivity. North American Journal of Fisheries Management 29:127-139. <https://doi.org/10.1577/M08-031.1>
- Frick L, Reina R, Walker T. 2010a. Stress related changes and post-release survival of Port Jackson sharks (*Heterodontus portusjacksoni*) and gummy sharks (*Mustelus antarcticus*) following gillnet and longline capture in captivity. Journal of Experimental Marine Biology and Ecology. 385:29-37. <https://doi.org/10.1016/j.jembe.2010.01.013>
- Frick L, Walker T, Reina R. 2010b. Trawl capture of Port Jackson sharks, *Heterodontus portusjacksoni*, and gummy sharks, *Mustelus antarcticus*, in a controlled setting: Effects of tow duration, air exposure and crowding. Fisheries Research 6:344-350. <https://doi.org/10.1016/j.fishres.2010.08.016>

- Gales NJ, Cheal AJ, Pobar GJ, Williamson P. 1992. Breeding biology and movements of Australian sea-lions, *Neophoca cinerea*, off the west coast of Western Australia. *Wildlife Research*. 19:405-15.
- Gales NJ, Shaughnessy PD, Dennis TE. 1994. Distribution, abundance and breeding cycle of the Australian sea lion *Neophoca cinerea* (Mammalia: Pinnipedia). *Journal of Zoology*. 234:353-70. <https://doi.org/10.1111/j.1469-7998.1994.tb04853.x>
- Gales NJ, Costa DP. 1997. The Australian sea lion: a review of an unusual life history. *Marine mammal research in the Southern Hemisphere*. 1:78-87.
- Gardner C. 1998. The first record of larvae of the giant crab *Pseudocarcinus gigas* in the plankton. *Papers and Proceedings of the Royal Society of Tasmania* 132:47–48. https://www.fish.gov.au/Archived-Reports/2012/reports/Documents/Gardner_1998.pdf
- Gardner C, Quintana R. 1998. Larval development of the Australian giant crab *Pseudocarcinus gigas* (Lamarck, 1818) (Decapoda: Oziidae) reared in the laboratory. *Journal of Plankton Research* 20:1169–1188. <https://doi.org/10.1093/plankt/20.6.1169>
- Gardner C, Williams H. 2002. Maturation of the male giant crab, *Pseudocarcinus gigas*, and the potential for sperm limitation in the Tasmanian fishery. *Marine and Freshwater Research*. 53:661-7. <https://doi.org/10.1071/MF01097>
- Gaughan DJ. 2002. Disease-translocation across geographic boundaries must be recognized as a risk even in the absence of disease identification: the case with Australian *Sardinops*. *Reviews in Fish Biology and Fisheries* 11:113-123. <https://doi.org/10.1023/A:1015255900836>
- Goldsworthy SD. 2015. Australian sea lion. *Neophoca cinerea*. The IUCN Red List of Threatened Species. Version 2015.2. e.T14549A45228341
- Goldsworthy SD, Shaughnessy PD, Mackay AI, Bailleul F, Holman D, Lowther AD, Page B, Waples K, Raudino H, Bryars S, Anderson T. 2021. Assessment of the status and trends in abundance of a coastal pinniped, the Australian sea lion *Neophoca cinerea*. *Endangered Species Research* 44:421-37. <https://doi.org/10.3354/esr01118>
- Hartmann K, Reilly D, How J, McLeay L. 2021. Giant Crab (2020) *Pseudocarcinus gigas*. In: T Piddocke, C Ashby, K Hartmann, A Hesp, P Hone, J Klemke, S Mayfield, A Roelofs, T Saunders, J Stewart, B Wise, J Woodhams (eds). 2021. Status of Australian Fish Stocks 2020. Fisheries Research and Development Corporation, Canberra. <https://fish.gov.au/report/300-Giant-Crab-2020>
- Hawkins AD, Popper AN. 2017. A sound approach to assessing the impact of underwater noise on marine fishes and invertebrates. *ICES Journal of Marine Science*, 74:635-651. <https://academic.oup.com/icesjms/article/74/3/635/2739034>
- Heeren T, Mitchell B. 1997. Morphology of the mouthparts, gastric mill and digestive tract of the giant crab, *Pseudocarcinus gigas* (Milne Edwards) (Decapoda: Oziidae). *Marine and Freshwater Research* 48:7-18. <https://doi.org/10.1071/MF96026>
- Hobday DK, Ryan TJ. 1997. Contrasting sizes at sexual maturity of southern rock lobsters (*Jasus edwardsii*) in the two Victorian fishing zones: implications for total egg production and management. *Marine and Freshwater Research*. 48:1009-14. <https://doi.org/10.1071/MF97143>
- Holthuis LB. 1991. Marine lobsters of the world. FAO fisheries synopsis Number 125 Volume 13. Rome, FAO. 292 p.
- How J, Coughran D, Double M, Rushworth K, Hebiton B, Smith J, Harrison J, Taylor M, Paton D, McPherson G, McPherson C, Salas AR, Salgado-Kent C, de Lestang S. 2020. Mitigation measures to reduce entanglements of migrating whales with commercial fishing gear. Fisheries Research Report No. 304. Department of Primary Industries and Regional Development, Western Australia https://library.dpird.wa.gov.au/fr_rr/118/
- How J, de Lestang S, Hebiton B, Denham A. 2022a. Development of an industry-funded fishery-independent survey and associated indices for managing a deep sea crab resource in Western Australia. *Fisheries Research* 251:106296. <https://doi.org/10.1016/j.fishres.2022.106296>

- How JR, de la Mare WK, Coughran DK, Double MC, de Lestang S. 2021. Gear modifications reduced humpback whale entanglements in a commercial rock lobster fishery. *Marine Mammal Science* 37:782–806. <https://doi.org/10.1111/mms.12774>
- How J, Tuffley, E, Oliver R, Evans S, Hourston M, de Lestang S. 2022b. Ecological risk assessment for the western rock lobster resource: Background information. Fisheries Research Report 328. Department of Primary Industries and Regional Development, Western Australia. https://www.fish.wa.gov.au/Documents/research_reports/fr328.pdf
- How J, Webster F, Travaille K, Nardi K, Harry A. 2015. West Coast Deep Sea Crustacean Managed Fishery. Western Australian Marine Stewardship Council Report Series No. 4. Department of Fisheries, Western Australia. 172pp. https://www.fish.wa.gov.au/Documents/wamsc_reports/wamsc_report_no_4.pdf
- Jones JB, Gibson AP. 1997 Risk analysis for the practice of importing frozen fish as bait. Western Australian Fishing Industry Council (Inc.), Perth, Australia.
- Kahn SA, Beers PT, Findlay VL, Peebles IR, Durham PJ, Wilson DW, Gerrity SE. 1999. Import Risk Analysis on Non-viable Salmonids and Non-salmonid Marine Finfish. Canberra, Australian Quarantine Inspection Service, Commonwealth of Australia. <https://www.agriculture.gov.au/sites/default/files/sitecollectiondocuments/ba/animal/horsesubmissions/finalfinfish.pdf>
- Kendrick G, Harvey E, McDonald J, Pattiaratchi C, Cappo M, Fromont J, Shortis M, Grove S, Bickers A, Baxter K, Goldberg N, Kletczkowski M, Butler J. 2005. Characterising the fish habitats of the Recherche Archipelago. FRDC Report 2001/060. <https://www.frdc.com.au/sites/default/files/products/2001-060-DLD.pdf>
- Kliska K, McIntosh RR, Jonsen I, Hume F, Dann P, Kirkwood R, Harcourt R. 2022. Environmental correlates of temporal variation in the prey species of Australian fur seals inferred from scat analysis. *Royal Society Open Science* 9:211723. <https://doi.org/10.1098/rsos.211723>
- Langlois T, Anderson M, Babcock R, Kato S. 2006. Marine reserves demonstrate trophic interactions across habitats. *Oecologia* 147:134-140. <https://link.springer.com/article/10.1007/s00442-005-0148-7>
- Levings A, Mitchell BD, McGarvey R, Mathews J, Laurenson L, Austin C, Heeron T, Murphy N, Miller A, Rowsell M. 2001. Fisheries biology of the giant crab *Pseudocarcinus gigas*. Project 93:220. Final report to the Fisheries Research and Development Corporation, Australia. <https://www.frdc.com.au/sites/default/files/products/1997-132-DLD.pdf>
- Lindholm R., 1984. Observations on the chinaman leatherjacket *Nelusetta ayraudi* (Quoy & Gaimard) in the Great Australian Bight. *Marine and Freshwater Research* 35:597-599. <https://doi.org/10.1071/MF9840597>
- Linnane A, Hobday D, Frusher S, Gardner C. 2011a. Growth rates of juvenile southern rock lobster (*Jasus edwardsii*) estimated through a diver-based tag–recapture program. *Marine and Freshwater Research* 63:110-118. <https://doi.org/10.1071/MF11121>
- Linnane A, McGarvey R, Feenstra J, Hoare M. 2011b. Northern Zone Rock Lobster (*Jasus edwardsii*) Fishery 2009/10. Fishery Assessment Report to PIRSA Fisheries and Aquaculture. South Australian Research and Development Institute (Aquatic Sciences), Adelaide. SARDI Publication No. F2007/000320-4. SARDI Research Report Series No. 561. 82pp. [https://www.fish.gov.au/Archived-Reports/2012/reports/Documents/Linnane et al 2011 b Northern Zone Rock Lobster Jasus edwardsii Fishery 2009 10.pdf](https://www.fish.gov.au/Archived-Reports/2012/reports/Documents/Linnane_et_al_2011_b_Northern_Zone_Rock_Lobster_Jasus_edwardsii_Fishery_2009_10.pdf)
- Linnane A, McGarvey R, Gardner C, Hartmann K, de Lestang S. 2021. Southern Rock Lobster 2020. In: T Piddocke, C Ashby, K Hartmann, A Hesp, P Hone, J Klemke, S Mayfield, A Roelofs, T Saunders, J Stewart, B Wise, J Woodhams (eds). 2021. Status of Australian Fish Stocks 2020. Fisheries Research and Development Corporation, Canberra. <https://fish.gov.au/report/294-Southern-Rock-Lobster-2020>
- MacDiarmid A, Cockcroft A, Butler M. 2011. *Projasus parkeri*. The IUCN Red List of Threatened Species 2011: e.T170042A6718864. <https://dx.doi.org/10.2305/IUCN.UK.2011-1.RLTS.T170042A6718864.en> Accessed on 18 November 2022.

- MacDiarmid A, Freeman D, Kelly S. 2013. Rock lobster biology and ecology: contributions to understanding through the leigh marine laboratory 1962-2012. *New Zealand Journal of Marine and Freshwater Research* 47:313-333. <https://doi.org/10.1080/00288330.2013.810651>
- McEnnulty FR, Gowlett-Holmes KL, Williams A, Althaus F, Fromont J, Poore GCB, O'Hara TD, Marsh L, Kott P, Slack-Smith S, Alderslade P, Kitahara MV. 2011. The deepwater megabenthic invertebrates on the western continental margin of Australia (100-1100 m depths) composition, distribution and novelty. https://museum.wa.gov.au/sites/default/files/SuppWAMuseum_2011_80_1to191_McENNULTYetal.pdf
- McGarvey R, Ferguson GJ, Prescott JH. 1999. Spatial variation in mean growth rates at size of southern rock lobster, *Jasus edwardsii*, in South Australian waters. *Marine and Freshwater Research*. 50:333-42. <https://doi.org/10.1071/MF97172>
- McGarvey R, Levings AH, Matthews JM. 2002. Moulting growth of the Australian giant crab, *Pseudocarcinus gigas*. *Marine and Freshwater Research*. 53:869-81. <https://doi.org/10.1071/MF00074>
- McIntosh R. 2007. The life history and population demographics of the Australian sea lion, *Neophoca cinerea*. PhD thesis, La Trobe University, Bundoora, Victoria. 367 pp.
- Mackay AI, Goldsworthy SD. 2017. Experimental field trials to test if alternative sea lion excluder devices (SLEDs) adequately prevent Australian sea lions from entering rock lobster pots. Fisheries Research and Development Corporation and South Australian Research and Development Institute. <https://www.frdc.com.au/sites/default/files/products/2016-055-DLD.pdf>
- Melville-Smith R, Norton SMG, Thomson AW. 2007. Biological and fisheries data for managing deep sea crabs in Western Australia. Final FRDC report -project 2001/055. Fisheries Research Report 165. Department of Fisheries, Western Australia.
- Miller ME, Stewart J. 2009. The commercial fishery for ocean leatherjackets (*Nelusetta ayraudi*, Monacanthidae) in New South Wales, Australia. *Asian Fisheries Science* 22:257-264. <https://core.ac.uk/download/pdf/33015852.pdf>
- Miller ME, Stewart J. 2013. Reproductive characteristics of the ocean leatherjacket, *Nelusetta ayraudi*. *Reviews in Fish Biology and Fisheries* 23:87-101. <https://doi.org/10.1007/s11160-012-9277-3>
- Moore SE, Hesp SA, Hall NG, Potter IC. 2007. Age and size compositions, growth and reproductive biology of the breaksea cod *Epinephelides armatus*, a gonochoristic serranid. *Journal of Fish Biology* 71:1407-1429. <https://doi.org/10.1111/j.1095-8649.2007.01614.x>
- Newman SJ, Wise BS, Santoro KG, Gaughan DJ (eds). (in prep.) Status Reports of the Fisheries and Aquatic Resources of Western Australia 2021/22: The State of the Fisheries. Department of Primary Industries and Regional Development, Western Australia.
- Norriss J, Watt M. 2021 South Coast Demersal Scalefish Resource Status Report 2021 (in) Status Reports of the Fisheries and Aquatic Resources of Western Australia 2020/21: The State of the Fisheries (eds. Newman SJ, Wise BS, Santoro KG, Gaughan DJ). Department of Primary Industries and Regional Development, Western Australia. pp 224-228. https://www.fish.wa.gov.au/Documents/sofar/status_reports_of_the_fisheries_and_aquatic_resources_2020-21.pdf
- Ovenden JR, Brasher DJ, White RW. 1992. Mitochondrial DNA analyses of the red rock lobster *Jasus edwardsii* supports an apparent absence of population subdivision throughout Australasia. *Marine Biology* 112:319-26. <https://doi.org/10.1007/BF00702478>
- Page B, McKenzie J, Sumner MD, Coyne M, Goldsworthy SD. 2006. Spatial separation of foraging habitats among New Zealand fur seals. *Marine Ecology Progress Series* 323:263-79. <https://www.int-res.com/articles/meps2006/323/m323p263.pdf>
- Perkins HC. 1973. The larval stages of the deep sea red crab, *Geryon quinquegens* Smith, reared under laboratory conditions (Decapoda: Brachyrhyncha). *Fisheries Bulletin* 71:69-82. <https://spo.nmfs.noaa.gov/sites/default/files/pdf-content/1973/711/perkins.pdf>
- Pitcher B. 2018 Australian Sea Lion Monitoring Framework: background document. Prepared for the Department of Fisheries and Aquatic Resources of Western Australia.

<https://www.dcceew.gov.au/environment/marine/publications/australian-sea-lion-monitoring-framework-background-document-2018>

Potter, A, Southby C, Heap AD. 2006. Geomorphology and Sedimentology of the South West Planning Region of Australia. Geoscience Australia, Record 2006/XX. Geoscience Australia, Canberra. 130pp. <https://parksaustralia.gov.au/marine/pub/scientific-publications/archive/sw-geomorphology-spatial.pdf>

Punt AE, Hobday D, Gerhard J, Troynikov VS. 2006. Modelling growth of rock lobsters, *Jasus edwardsii*, off Victoria, Australia using models that allow for individual variation in growth parameters. Fisheries Research 82:119-30. <https://doi.org/10.1016/j.fishres.2006.08.003>

Richardson W, Greene C, Malme C, Thomson D. 1995. Marine mammals and noise. Academic Press, San Diego, CA.

Ryan KL, Wise BS, Hall NG, Pollock KH, Sulin EH, Gaughan DJ. 2013. An integrated system to survey boat-based recreational fishing in Western Australia 2011/12. Fisheries Research Report No. 249. https://www.fish.wa.gov.au/Documents/research_reports/frr249.pdf

Ryan KL, Hall NG, Lai EK, Smallwood CB, Taylor SM, Wise BS. 2015. State-wide survey of boat-based recreational fishing in Western Australia 2013/14. Fisheries Research Report No. 268. https://www.fish.wa.gov.au/Documents/research_reports/frr268.pdf

Ryan KL, Hall NG, Lai EK, Smallwood CB, Taylor SM, Wise BS. 2017. Statewide survey of boat-based recreational fishing in Western Australia 2015/16. Fisheries Research Report No. 287. https://www.fish.wa.gov.au/Documents/research_reports/frr287.pdf

Ryan KL, Hall NG, Lai EK, Smallwood CB, Taylor SM, Wise BS. 2019. Statewide survey of boat-based recreational fishing in Western Australia 2017/18. Fisheries Research Report No. 297. https://www.fish.wa.gov.au/Documents/research_reports/frr297.pdf

Ryan KL, Lai EK, Smallwood CB. 2022. Statewide survey of boat-based recreational fishing in Western Australian 2020/21. Fisheries Research Report No. 327. https://www.fish.wa.gov.au/Documents/research_reports/frr327.pdf

Simpfendorfer C, Chin A, Rigby C, Sherman S, White W. 2019. Shark futures: a report card for Australia's sharks and rays. Centre for Sustainable Tropical Fisheries and Aquaculture, James Cook University. <https://www.frdc.com.au/sites/default/files/products/2013-009-DLD.pdf>

Shaughnessy PD, Goldsworthy SD, Hamer DJ, Page B, McIntosh RR. 2011. Australian sea lions *Neophoca cinerea* at colonies in South Australia: distribution and abundance, 2004 to 2008. Endangered Species Research 13:87-98. <https://doi.org/10.3354/esr00317>

Smallwood CB, Ryan KL, Tate AC, Desfosses CJ. 2021. Recreational fishing for Western Rock Lobster: estimates of participation, effort and catch from 2018/19 - 2020/21. Fisheries Research Report No. 313. https://www.fish.wa.gov.au/Documents/research_reports/frr313.pdf

Smallwood CB, Ryan KL, Tate AC, Rudd LJ. 2022. Recreational fishing for Western Rock Lobster: estimates of participation, effort and catch in 2021/22. Fisheries Research Report No. 325. https://www.fish.wa.gov.au/Documents/research_reports/frr325.pdf

Smith KD, Hall NG, Potter IC. 2004a. Relative abundances and size compositions of champagne crabs, *Hypothalassia acerba*, on two coasts and in different water depths and seasons. Marine and Freshwater Research 55:653–661. <https://doi.org/10.1071/MF04063>

Smith KD, Potter IC, Hesp A. 2004b. Comparisons between the reproductive biology of females of two species of deep sea crabs that live in different water depths. Journal of Shellfish Research 23:887–896. https://archive.org/details/cbarchive_40273_comparisonsbetweenthereproduct1981

Smith JN, Jones D, Travouillon K, Kelly N, Double M, Bannister JL. 2021. Monitoring Population Dynamics of 'Western' Right Whales off Southern Australia 2018-2021 - Final Report on activities for 2020. Report to the National Environmental Science Program, Marine Biodiversity Hub. Western Australian Museum. https://www.nespmarine.edu.au/system/files/Smith%20et%20al_A7_M17_%20Final%20report%20on%20activities%20for%202020.pdf

- Smoothey A, Krueck N, Fowler A, Emery T. 2021. Ocean Jacket 2020 *Nelusetta ayraudi*. In: Pidcocke T, Ashby C, Hartmann K, Hesp A, Hone P, Klemke J, Mayfield S, Roelofs A, Saunders T, Stewart S, Wise B and Woodhams J (eds). 2021. Status of Australian fish stocks reports 2020. Fisheries Research and Development Corporation, Canberra. <https://www.fish.gov.au/report/401-Ocean-Jacket-2020>
- Stamation K, Watson M, Moloney P, Charlton C, Bannister J. 2020. Population estimate and rate of increase of southern right whales *Eubalaena australis* in southeastern Australia. Endangered Species Research. 41:373-83. <https://www.int-res.com/articles/esr2020/41/n041p373.pdf>
- Stoklosa R. 2013 West Coast Rock Lobster Fishery Ecological Risk Assessment 20 February 2013. Government of Western Australia Department of Fisheries.
- Stoklosa R. 2022. Ecological Risk Assessment for the Western Rock Lobster Resource; Workshop Procedure and Outcomes. Fisheries Occasional Paper No. 142. Department of Primary Industries and Regional Development, Western Australia.
- Taylor IR, Roe EL. 2004. Feeding ecology of little terns *Sterna albifrons* sinensis in south-eastern Australia and the effects of pilchard mass mortality on breeding success and population size. Marine and Freshwater Research 55:799-808. <https://doi.org/10.1071/MF03203>
- Ward TM, Hoedt F, McLeay L, Dimmlich WF, Jackson G, Rogers PJ, Jones K. 2001. Have recent mass mortalities of the sardine *Sardinops sagax* facilitated an expansion in the distribution and abundance of the anchovy *Engraulis australis* in South Australia? Marine Ecology Progress Series 220:241-251. <https://www.int-res.com/articles/meps/220/m220p241.pdf>
- Watt M, Braccini M, Smith KA, Hourston M. 2021. Ecological Risk Assessment for the Temperate Demersal Elasmobranch Resource. Fisheries Research Report No. 318. Department of Primary Industries and Regional Development, Western Australia. 110 pp. https://www.fish.wa.gov.au/Documents/research_reports/fr318.pdf
- Whittington RJ, Crockford M, Jordan D, Jones B. 2008. Herpesvirus that caused epizootic mortality in 1995 and 1998 in pilchard, *Sardinops sagax neopilchardus* (Steindachner), in Australia is now endemic. Journal of Fish Diseases 31:97-105. <https://doi.org/10.1111/j.1365-2761.2007.00869.x>
- Williams A, Gardner C, Althaus F, Barker B, Mills D. 2009. Understanding the shelf-break habitat for sustainable management of fisheries with spatial overlap. Page Final report to the Fisheries Research and Development Corporation: project no. 2004/066. http://frdc.com.au/research/Documents/Final_reports/2004-066-DLD.pdf.
- Visconti V, Trip ED, Griffiths MH, Clements KD. 2018a. Life-history traits of the leatherjacket *Meuschenia scaber*, a long-lived monacanthid. Journal of Fish Biology 92:470-486. <https://doi.org/10.1111/jfb.13529>
- Visconti V, Trip ED, Griffiths MH, Clements KD. 2018b. Reproductive biology of the leatherjacket, *Meuschenia scaber* (Monacanthidae) (Forster 1801) in the Hauraki Gulf, New Zealand. New Zealand Journal of Marine and Freshwater Research 52:82-99. <https://doi.org/10.1080/00288330.2017.1331919>

Appendix 1: Consequence – Likelihood Risk Matrix and Description of Risk Levels

Consequence – Likelihood Risk Matrix (based on AS 4360 / ISO 31000; adapted from Department of Fisheries 2015).

		Likelihood			
		Remote (1)	Unlikely (2)	Possible (3)	Likely (4)
Consequence	Minor (1)	Negligible	Negligible	Low	Low
	Moderate (2)	Negligible	Low	Medium	Medium
	High (3)	Low	Medium	High	High
	Major (4)	Low	Medium	Severe	Severe

Description of risk levels applied to evaluate individual risk issues (modified from Fletcher 2005).

Risk Levels	Description	Likely Reporting and Monitoring Requirements	Likely Management Action
Negligible	Acceptable; Not an issue	Brief Notes – no monitoring	Nil
Low	Acceptable; No specific control measures needed	Full Notes needed – periodic monitoring	None specific
Medium	Acceptable; With current risk control measures in place (no new management required)	Full Performance Report – regular monitoring	Specific management and/or monitoring required
High	Not desirable; Continue strong management actions OR new / further risk control measures to be introduced in the near future	Full Performance Report – regular monitoring	Increased management activities needed
Severe	Unacceptable; Major changes required to management in immediate future	Recovery strategy and detailed monitoring	Increased management activities needed urgently

Appendix 2: Definitions of Consequence and Likelihood Levels

LIKELIHOOD LEVELS:

1	Remote	The consequence has never been heard of in these circumstances, but it is not impossible within the timeframe (Probability <5%).
2	Unlikely	The consequence is not expected to occur in the timeframe but it has been known to occur elsewhere under special circumstances (Probability 5 - <20%).
3	Possible	Evidence to suggest this consequence level is possible and may occur in some circumstances within the timeframe (Probability 20 - <50%).
4	Likely	A particular consequence level is expected to occur in the timeframe (Probability ≥50%).

CONSEQUENCE LEVELS:

1. Target/Primary Retained Species		
1	Minor	Fishing impacts either not detectable against background variability for this population; or if detectable, minimal impact on population size and none on dynamics. Spawning biomass > Target level
2	Moderate	Fishery operating at maximum acceptable level of depletion. Spawning biomass < Target level but > Threshold level (B_{MSY})
3	High	Level of depletion unacceptable but still not affecting recruitment levels of stock. Spawning biomass < Threshold level (B_{MSY}) but > Limit level (B_{REC})
4	Major	Level of depletion is already affecting (or will definitely affect) future recruitment potential of the stock. Spawning biomass < Limit level (B_{REC})

2. Bycatch/Non-Target Species		
1	Minor	Measurable but minor levels of depletion of fish stock.
2	Moderate	Maximum acceptable level of depletion of stock.
3	High	Level of depletion of stock unacceptable but still not affecting recruitment level of the stock.
4	Major	Level of depletion of stock are already affecting (or will definitely affect) future recruitment potential of the stock.

3. Endangered, Threatened and Protected Species (TEPs)		
1	Minor	Few individuals directly impacted in most years.
2	Moderate	Level of capture is the maximum that will not impact on recovery.
3	High	Recovery may be affected.
4	Major	Recovery times are clearly being impacted.

4. Habitat		
1	Minor	Measurable impacts but very localised. Area directly affected well below maximum accepted.
2	Moderate	Maximum acceptable level of impact to habitat with no long-term impacts on region-wide habitat dynamics.
3	High	Above acceptable level of loss/impact with region-wide dynamics or related systems may begin to be impacted.
4	Major	Level of habitat loss clearly generating region-wide effects on dynamics and related systems.

5. Ecosystem/Environment		
1	Minor	Measurable but minor changes to the environment or ecosystem structure but no measurable change to function.
2	Moderate	Maximum acceptable level of change to the environment or ecosystem structure with no material change in function.
3	High	Ecosystem function altered to an unacceptable level with some function or major components now missing and/or new species are prevalent.
4	Major	Long-term, significant impact with an extreme change to both ecosystem structure and function; different dynamics now occur with different species/groups now the major targets of capture or surveys.

Appendix 3: ERA workshop stakeholders

List of invited ERA workshop stakeholders.

Name	Organisation
Doug Hall	Aquaculture Council of Western Australia
Leo Guida	Australian Marine Conservation Society
Morgan Hand	Commercial representative
Manue Daniels	Commercial representative
Graeme Pateman	Commercial representative
Manue Daniels	Commercial representative
Adam Towers-Hammond	Commercial representative
Nick Soulos	Commercial representative
Neville Mansted	Commercial representative
Matt Howard	Commercial representative
Mt Sopris Pty Ltd	Commercial representative
Malcolm Phillips	Commercial representative
Estate of the late Hugh Colin Gilbert	Commercial representative
Vincent and Marlene Mueller	Commercial representative
Latitude Fisheries PTY Ltd	Commercial representative
Wanteen Fishing Company	Commercial representative
Helen Martin	Commercial representative
Fiskehand Pty Ltd	Commercial representative
Kybret Pty Ltd	Commercial representative
Tonkin Fisheries Pty Ltd	Commercial representative
Leighton Matthews	Commercial representative
Dulzurah Pty Ltd	Commercial representative
Jortee Pty Ltd	Commercial representative
Mojo Fishing Company Pty Ltd	Commercial representative
Miles/Marnup Park	Commercial representative
Eureka Fisheries Pty Ltd	Commercial representative
Steven Davies	Commercial representative
Jo Elphinstone	Commonwealth Dept. of Agriculture, Fisheries & Forestry
Maggie Wood	Conservation Council WA
UNESCO World Heritage sites	Department of Foreign Affairs and Trade
Matt Flood	Dept. of Climate Change, Energy, the Environment & Water
Rebecca Oliver	DPIRD (Aquatic Resource Management)
Linda Wiberg	DPIRD (Aquatic Resource Management)
Dr Jason How	DPIRD (Aquatic Science and Assessment)
Dr Scott Evans	DPIRD (Aquatic Science and Assessment)
Dr Kim Smith	DPIRD (Aquatic Science and Assessment)
Dr Steve Taylor	DPIRD (Aquatic Science and Assessment)
Dr Simon de Lestang	DPIRD (Aquatic Science and Assessment)
Hannah Donnelly	DPIRD (Aquatic Science and Assessment)
Dr Nick Caputi	DPIRD (Aquatic Science and Assessment)
Dr Lynda Belchambers	DPIRD (Aquatic Science and Assessment)
Dr Katie Webb	DPIRD (Biosecurity)
Rob Gurney	DPIRD (Biosecurity)
Dr Sam Bridgwood	DPIRD (Biosecurity)
Noel Chambers	DPIRD (Compliance)
Mick Kelly	DPIRD (Compliance)
Dan Oswald	DPIRD (Compliance)
Bob Bogumil	DPIRD (Compliance)
Ben Doncon	DPIRD (Compliance)

Chandra Salgado-Kent
Peter Bednall
Caleb Gardner
Matt Watson
Leyland Campbell
Jeff Hansen
na
Tim Langlois
Dr Holly Raudino
Dr Kelly Waples
Graeme Baudains
Tessa Ramshaw
Terry Lissiman
Matt Taylor
na

Edith Cowan University
Esperance Tjaltjraak Native Title Aboriginal Corporation
Institute of Marine and Antarctic Science, Tasmania
Marine Stewardship Council
Recfishwest
Sea Shepherd
South West Aboriginal Land and Sea Council
UWA
WA Department of Biodiversity, Conservation and Attractions
WA Department of Biodiversity, Conservation and Attractions
Western Australian Fishing Industry Council
Western Australian Fishing Industry Council
Western Rock Lobster Board
Western Rock Lobster Council
WWF

List of ERA workshop apologies.

Name	Organisation
Graeme Pateman	Commercial representative
Adam Towers-Hammond	Commercial representative
Nick Soulos	Commercial representative
Neville Mansted	Commercial representative
Dr Kelly Waples	WA Department of Biodiversity, Conservation and Attractions
Jo Elphinstone	Commonwealth Department of Agriculture, Fisheries & Forestry
Caleb Gardner	Institute of Marine and Antarctic Science, Tasmania
Leo Guida	Australian Marine Conservation Society
Leyland Campbell	Recfishwest
Mick Kelly	DPIRD (Compliance)
Dan Oswald	DPIRD (Compliance)
Bob Bogumil	DPIRD (Compliance)
Ben Doncon	DPIRD (Compliance)
Dr Katie Webb	DPIRD (Biosecurity)
Rob Gurney	DPIRD (Biosecurity)
Dr Nick Caputi	DPIRD (Aquatic Science and Assessment)
Dr Sam Bridgwood	DPIRD (Biosecurity)
Linda Wiberg	DPIRD (Aquatic Resource Management)

List of ERA workshop attendees.

Name	Organisation
Graeme Baudains	Western Australian Fishing Industry Council
Tessa Ramshaw	Western Australian Fishing Industry Council
Morgan Hand	Commercial representative
Manue Daniels	Commercial representative
Matt Watson	Marine Stewardship Council
Dr Holly Raudino	WA Department of Biodiversity, Conservation and Attractions
Rebecca Oliver	DPIRD (Aquatic Resource Management)
Dr Jason How	DPIRD (Aquatic Science and Assessment)
Dr Scott Evans	DPIRD (Aquatic Science and Assessment)
Dr Kim Smith	DPIRD (Aquatic Science and Assessment)
Dr Steve Taylor	DPIRD (Aquatic Science and Assessment)
Dr Simon de Lestang	DPIRD (Aquatic Science and Assessment)
Hannah Donnelly	DPIRD (Aquatic Science and Assessment)
Noel Chambers	DPIRD (Compliance)