



Department of
**Primary Industries and
Regional Development**

Fisheries Research Report No. 329

Developing novel remote camera approaches to assess and monitor the population status of Australian sea lions

FRDC Project No. 2017/119

Mat Hourston, Daniela Waltrick, Stuart Blight, Ainslie Denham,
Alex Hesp, Stephen Taylor

December 2022



Correct citation:

Hourston, M., Waltrick, D., Blight, S., Denham, A., Hesp, A., Taylor, S. 2022. Developing novel remote camera approaches to assess and monitor the population status of Australian sea lions. Fisheries Research Report No. 329 Department of Primary Industries and Regional Development, Western Australia. 78pp.

Enquiries:

WA Fisheries and Marine Research Laboratories,
PO Box 20,
North Beach, WA 6920

Tel: +61 8 9203 0111

Email: library@fish.wa.gov.au

Website: fish.wa.gov.au

A complete list of Fisheries Research Reports is available online at **fish.wa.gov.au**

Important disclaimer

The Chief Executive Officer of the Department of Primary Industries and Regional Development and the State of Western Australia accept no liability whatsoever by reason of negligence or otherwise arising from the use or release of this information or any part of it.

Department of Primary Industries and Regional Development
Gordon Stephenson House
140 William Street
PERTH WA 6000
Telephone: (08) 6551 4444
Website: dpiird.wa.gov.au
ABN: 18 951 343 745

ISSN: 2202-5758 (Online) ISBN: 978-1-921845-32-1 (Online)

Copyright © State of Western Australia (Department of Primary Industries and Regional Development) 2022

Table of Contents

Acknowledgements	viii
Abbreviations	viii
Executive Summary	1
1.0 Introduction	5
1.1 Background	5
1.2 Legislated protection of Australian sea lions	6
1.3 Developing novel monitoring tools	6
2.0 Objectives	9
3.0 Method	10
3.1 Site descriptions	10
3.1.1 Buller Island	10
3.1.2 Haul Off Rock.....	11
3.1.3 Wickham Island.....	13
3.2 Camera system	15
3.2.1 Hardware	15
3.2.2 Camera maintenance and data retrieval schedule	21
3.2.3 Software and camera configuration.....	22
3.3 Video sampling design and animal classification	23
3.3.1 Video processing.....	23
3.4 Animal classification	26
3.4.1 Pups	27
3.4.2 Juveniles	28
3.4.3 Cows	29
3.4.4 Subadult males (SAMs)	29
3.4.5 Bulls	30
3.4.6 Unknown	31
3.4.7 Long nose fur seals.....	31
3.5 Mortalities and entanglements	32
3.6 Other biological observations	32
3.7 Analysis and modelling	32
3.7.1 Preliminary analysis of “video” read data	32
3.7.2 Analysis and modelling of “still” read data	32
3.7.3 Comparison between camera and BoG data sets.....	34
4.0 Results	35
4.1 Developing an appropriate read technique	35

4.1.1 Protocol 1: Video read.....	35
4.1.2 Protocol 2: Still read	37
4.1.3 Preferred reading approach	37
4.2 Objective 1: Evaluate the feasibility of using remote cameras as a method for monitoring the status of Australian sea lion colonies.	38
4.2.1 Provide continuous footage.....	38
4.2.2 Perform under different environmental conditions.....	43
4.2.3 Enable identification of pinnipeds from the camera footage.....	43
4.2.4 Distinguish ASLs from other pinnipeds from the camera footage.....	44
4.2.5 Identify different population demographics or age classes from the camera footage	44
4.2.6 Identify individual animals	44
4.2.7 Determine whether sub-lethal entanglements or mortalities had occurred	44
4.2.8 Record behavioural observations for other animals	46
4.3 Objective 2: Collect sea lion abundance estimates from study colonies over an 18-month period (full breeding cycle) to update understanding of their conservation status.	48
4.3.1 Variations in MaxN	48
4.3.2 Time series analysis for Buller Island data	55
4.3.3 Comparison between camera and BoG data sets.....	56
4.4 Objective 3: Provide continuous time-series vision and ancillary in-situ data for other ecological or behavioural research in dynamics of WA sea lion colonies.	58
5.0 Discussion.....	59
5.1 Objective 1. Evaluate the feasibility of using remote cameras as a method for monitoring the status of Australian sea lion colonies.	59
5.2 Objective 2. Collect sea lion abundance estimates from study colonies over an 18-month period (full breeding cycle) to update understanding of their conservation status.	63
5.3 Objective 3. Provide continuous time-series vision and ancillary in-situ data for other ecological or behavioural research in dynamics of WA sea lion colonies.	64
5.4 Conclusion	65
6.0 Implications and Recommendations.....	67
6.1 Monitoring the abundance of ASLs and the potential impacts of commercial fishing	67
6.2 More cost-effective BoG surveys	67
6.3 General Behavioural/Ecological Research	68

6.4 Validating deep learning models that can automate the detection of ASLs from camera footage	68
7.0 Extension and Adoption	69
8.0 Project materials developed	70
9.0 References	71
Appendix A: Project staff	75
Appendix B: Buller Island schedule of camera uptime	76
Appendix C: Haul Off Rock schedule of camera uptime	77
Appendix D: Wickham Island schedule of camera uptime	78

List of Figures

Figure 1. Map of Western Australia indicating the three ASL colonies chosen for remote camera monitoring.	10
Figure 2. Buller Island foreshore showing camera array (refer to yellow box).	11
Figure 3. Northern face of Haul Off Rock from the water.	12
Figure 4. View to the west from half-way up the island dome at Haul Off Rock.	12
Figure 5. Long-nosed fur seal cow and pup observed near the water's edge at Haul Off Rock.	13
Figure 6. View from the northern point of Wickham Island looking southwest towards Gulch, Owen and Middle Islands.	14
Figure 7. Long nosed fur seal at Wickham Island.	14
Figure 8. Schematic of camera components.	17
Figure 9. The camera system component arrangement within the secure enclosure.	18
Figure 10. Camera array on Buller Island.	18
Figure 11. Camera array on Haul Off Rock.	19
Figure 12. Camera array on Wickham Island.	19
Figure 13. Mainland base station for Wickham Island at Cape Arid.	20
Figure 14. Extend range transmission unit.	21
Figure 15. Still image from the Buller Island camera showing the boundaries of the field of view, including the sections of the boundary used in the "video read" analysis.	23
Figure 16. Still image from the Haul Off Rock camera showing the boundaries of the field of view used in the "video read" analysis.	24
Figure 17. Buller Island showing a very short beach profile.	24
Figure 18. Buller Island showing a very long beach profile.	25
Figure 19. Still frame from Buller Island footage showing ASLs classified into demographic classes. Yellow = pups, pink=cow, blue = bull, green= sub adult male, red = unknown.	26
Figure 20. Images from Buller Island showing (a) ASL pup and (b) ASL cow nursing a pup.	28
Figure 21. Image from Buller Island; three cows are visible on the beach in the middle of the picture, one bull is visible on the beach on the right-hand side of the image.	29
Figure 22. Image from Wickham Island showing a subadult male.	30

Figure 23. Still frame from the Haul Off Rock footage showing a bull (blue circle) and a sub-adult male (green circle).	30
Figure 24. Footage of ASL bulls taken at (a) Wickham Island and (b) Buller Island.	31
Figure 25. Representation of the "video read" data from one single day (15/08/2018) at Buller Island, aggregated into 5-minute time intervals: a) number of transits across the beach/inland FoV boundary; b) number of transits across the beach/ocean FoV boundary; c) stacked histogram showing the total number and class composition of the animals within the FoV. For panels a and b, positive values indicate animals moving into the FoV while negative values indicate animals leaving the FoV, and narrow black bars indicate net movement during that time interval.	36
Figure 26. Representation of the "still read" data from the full time series of readable days over the study period at Buller Island. Coloured, filled circles represent the greatest number of each demographic class on each day (MaxN). Open circles represent counts of each demographic class at 15-minute intervals that were less than the MaxN.	37
Figure 27. Counts of the demographic classes of ASL at Buller Island in each 15-minute interval recorded over a 14-day period using the still read protocol. Fitted line visualises the window of time in which the MaxN consistently occurred. Grey shaded box (13:00-17:00) refers to the 'restricted' period used for subsequent analysis.	38
Figure 28. Camera uptime at Buller Island between August 2018 and March 2020 read at 15-minute intervals between 13:00 and 17:00. Observation times with valid counts are depicted by solid circles.	40
Figure 29. Camera uptime at Wickham Island between November 2018 and October 2019 read at 15-minute intervals between 13:00 and 17:00. Observation times with valid counts are depicted by solid circles.	41
Figure 30. Image resolution comparison at Wickham Island demonstrating images acquired with (a) a fully functioning system and full-size images (3072x2048) and (b) a compromised system remotely reconfigured to acquire images at an increased period and reduced resolution (1536x1024) to reduce the loss of data.	42
Figure 31. Still frame taken at Buller Island showing two pup mortalities marked with red asterisk.	45
Figure 32. Image of (a) skull of an ASL adult and (b) body of a dead ASL pup taken at Wickham Island.	46
Figure 33. Sequence of three frames showing a raptor attempting to attack a young ASL at Wickham Island.	47
Figure 34. Maximum daily counts for all categories of ASL at Buller Island. Red line represents camera downtime.	50
Figure 35. Average daily maximum count by week for all categories of ASL at Buller Island.	51
Figure 36. Box and whisker plots showing daily maximum count data at Buller Island grouped by month for pups (red) and cows (blue). Solid horizontal black line within each box represents the median value, lower and upper edges of each box represent the 25 th and 75 th percentiles Lower and upper extremities of the vertical line for each month indicate the most extreme data point which is no more than 1.5 times the interquartile range, with outliers indicated by solid circles.	52
Figure 37. Maximum daily counts for each category of ASL at Wickham Island. Red line represents camera downtime.	53
Figure 38. Maximum daily counts for each category of ASL at Haul Off Rock.	54
Figure 39. Sinusoidal models fitted to maximum daily count of pups and cows at Buller Island assuming a negative binomial error distribution. Dark shaded regions	

indicate estimated 95% confidence regions, and light shaded regions indicate 95% prediction regions. Shaded grey vertical lines indicate peaks and troughs in estimated counts. Horizontal pink and blue lines indicate mean pup and cow count levels, respectively, with associated dotted pink and blue lines indicating the lower and upper 95% confidence limits. 56

Figure 40. Comparison between pup counts obtained from the camera data (MaxN, indicated by black circles) and from boots on the ground surveys (BoG, indicated by blue circles) at Buller Island while the camera was operational. Differences in data comparability are discussed in the Methods section. 57

Figure 41. Comparison of pup counts between the camera time series analysis and from boots on the ground surveys (BoG) at Buller Island. Values for BoG surveys were provided by the DBCA and also reported in Goldsworthy et al., 2021 (Supplementary Material). Dotted line for the camera data represents the fitted sinusoidal model, solid black circle represents the upper prediction limit (refer to Figure 35). Differences in data comparability are discussed in the Methods section. 58

Figure 42. Remote Piloted Aircraft images taken in the Recherche Archipelago in January 2022 where ASLs and LNFS are both visible: (a) on the rock taken off Daw Island and (b) on New Year Island, adjacent to Daw Island. Vessel visible in the background is used as a platform for RPA operations. 62

List of Tables

Table 1. Specifications and model numbers of the electronic components used in the camera system arrays. 16

Table 2. Estimates, standard errors and 95% confidence intervals of derived variables for the Buller Island timer series data. C = mean, A = amplitude, ω = period, φ = phase, θ = dispersion parameter, AIC = Akaike’s Information Criterion..... 55

Acknowledgements

We acknowledge that this project was supported by funding from the FRDC on behalf of the Australian Government. We thank Adrienne Laird (FRDC) and Selina Cranley (DPIRD) for administrative support. We thank Rory McAuley (former-DPIRD) for preparing the original project application. We are grateful for feedback on the project provided by industry members of the Temperate Demersal Gillnet and Demersal Longline Fisheries and the South Coast Crustacean Managed Fishery during industry meetings. We thank the Esperance Professional Fishermen's Association and the Western Australian Fishing Industry Council for providing initial letters of support for the project application. We are grateful for the field assistance provided by Department of Biodiversity, Conservation and Attraction staff (DBCA), particularly Jon Pridham, Emma Rowe and Lisa West (now DPIRD). We thank Kelly Waples (DBCA) and Holly Raudino (DBCA) for access to DBCA ASL data and for scientific input into the report. We thank the following DPIRD staff for field support: Robert Bogumil, Ally Jennings, Jack Dawson and Russell Adams. We thank Matias Braccini, Maddison Watt, Stephanie Nicoloff, and Lynda Bellchambers for reviewing an earlier draft of this report as per the DPIRD internal review process.

Abbreviations

ASL	Australian sea lion
BoG	Boots-on-Ground
DPIRD	Department of Primary Industries and Regional Development
FoV	Field of view
LNFS	Long-nosed fur seals
RPA	Remotely Piloted Aircraft
SA	South Australia
SAM	Sub-adult male
TDGDLF	Temperate Demersal Gillnet Demersal Longline Fisheries
WA	Western Australia

ASL metapopulations:

NUYT	Nuytsland ASL metapopulation
WASC1	Eastern Recherche ASL metapopulation
WASC2	Esperance ASL metapopulation
WASC3	Albany ASL metapopulation
WAWC1	Jurien ASL metapopulation
WAWCS	Abrolhos ASL metapopulation

Executive Summary

Overview

This project trialled the use of remote cameras to monitor the relative abundance of Australian sea lions (ASLs, *Neophoca cinerea*) at three Western Australian (WA) breeding colonies. The research was undertaken by the Department of Primary Industries and Regional Development (DPIRD) to assess whether the analysis of camera footage could be used to estimate ASL relative abundance, providing an alternative to the traditional “boots on the ground” approach (hereon in “BoG”) of visiting colonies to count animals. This report outlines the strengths and limitations of this novel approach rather than providing an update on the population status of ASLs.

Remote cameras and associated infrastructure were installed at Buller Island, Haul Off Rock and Wickham Island in the second half of 2018, after which camera images were manually interpreted with the intention of capturing data over an 18-month period (i.e., approximately one reproductive cycle). Overall, counts of ASLs were obtained from the analysis of 563 days (~6,700 hours) of camera footage. These data comprised the number of ASLs identified within the field of view (FoV) of each camera which represented relative abundance estimates for each colony. Day to day variations in the relative abundance of ASLs were estimated for Buller Island and Wickham Island, with limited data on ASL abundance collected for Haul Off Rock due to camera outages. The time series analysis applied to the Buller Island data provides the most detailed information within a single reproductive cycle at a WA colony. To ‘value-add’ from the original aims of the study, remote piloted aircraft (RPA) operations were also conducted within the Recherche Archipelago to provide a greater understanding of the potential application of both methods for on-going monitoring.

In summary, the diversity and remoteness of ASL colonies in WA means that no single survey method is likely to be appropriate for the monitoring of all colonies. Installing and maintaining remote cameras at 32 known ASL breeding colonies would be cost-prohibitive and logistically impractical. Instead, camera monitoring at strategic ASL colonies would provide a realistic prospect of collecting long-term abundance data for hard-to-reach Western Australian colonies which remains a challenging prospect using BoG surveys. The ability to view live camera footage could assist with the scheduling of BoG surveys so that on-site surveys can be conducted regularly and safely. Such an approach would require more formal research arrangements to be established between the various state agencies responsible for managing wildlife and fisheries. This project has provided an extensive permanent digital library of camera images that can be made available for use in subsequent ecological and fisheries-related studies.

Background

The ASL was listed as Vulnerable under the Commonwealth Environment Protection and Biodiversity Conservation (EPBC) Act 1999 in 2005. This listing was recently upgraded to Endangered under advice from the Commonwealth Threatened Species Scientific Committee (TSSC, 2020). The rationale for formally listing the ASL as an Endangered species is in recognition of its reduced population size from historical levels, projected future decline and small sub-population sizes. The recent change in status was prompted by re-evaluation of the existing body of knowledge for the species and a more rigorous synthesis of new information, rather than a genuine deterioration in the species’ status.

Traditional approaches to monitoring the status of ASL colonies in Australia have involved BoG sampling, where field staff visit the colony and perform a visual census of newborn pups. Newborn pup numbers, used as an index of abundance, are the most reliable basis for estimating ASL population size as this age group is easily recognisable and most likely to be on shore as they have not developed at sea foraging skills. Multiple site visits within a breeding season are often required to ensure that the peak in pup number is captured; however, this is usually impractical and costly for remote and difficult to access colonies. As a result, reliable information on the population size and trend of ASL abundance in most WA colonies is lacking.

To assess whether these issues can be addressed, remote cameras were installed at three separate WA colonies. The suitability of this innovative technique was assessed in terms of whether the camera footage could be used to obtain useful metrics to assist in on-going ASL monitoring.

Aims/objectives

The project aimed to provide a thorough understanding of the application of remote cameras for monitoring ASLs at WA colonies. The specific objectives were to:

- Evaluate the feasibility of using remote cameras as a method for monitoring the status of ASL colonies (Objective 1).
- Collect ASL counts (relative abundance) from study colonies over an 18-month period (full breeding cycle) to update understanding of their conservation status (Objective 2).
- Provide continuous time-series vision and ancillary *in-situ* data for other ecological or behavioural research in dynamics of WA ASL colonies (Objective 3).

Methodology

Daily counts of ASLs were recorded based on the analysis of remote camera data at three colonies. Video reading protocols were established for each site to fit the specific FOV constraints (*i.e.*, what the camera sees) of each location. Two different sampling approaches were initially applied to the data: (i) a “video” read technique and (ii) a “still” read technique. The “still read” technique proved to be more time- and cost-effective and was applied to all subsequent analysis. Single frame instantaneous counts of ASLs were performed every 15 minutes on the quarter hour throughout the day, in addition to the first daylight frame of the day and the last readable daylight frame of the day. Counts were undertaken for the following ontogenetic classes: pup, juvenile, cow, sub-adult male, bull and unknown. The daily maximum instantaneous count (MaxN) was used to examine changes in relative abundance of the various age classes within the reproductive cycle.

A sinusoidal curve was fitted to the time series of pups and cows at Buller Island to provide a better understanding of the variability in abundance within a breeding cycle. The count data for pups and cows consisted of daily MaxN values and were considered to potentially conform to one of two alternative distributions (Poisson and negative binomial). Confidence intervals and prediction intervals for the fitted sinusoidal curve were calculated using a parametric bootstrapping analysis.

Results/key findings

Eight camera performance metrics were developed to evaluate the feasibility of using remote cameras as a method for monitoring the status of ASL colonies (Objective 1). This included the ability of these cameras to collect long-term data. The overall percentage of camera uptime at Buller Island, Wickham Island and Haul Off Rock was 62.2%, 57.1% and 2.1%, respectively. Attempts were made to sustain functionality at Haul Off Rock; however, the lack of field staff due to emerging priorities meant that the technical issues encountered on the island could not be rectified in a timely manner. The camera at Haul Off Rock was reconfigured to record still images at 20-minute intervals for an additional 105 days, or 25.4% of the period; however, these images were not analysed as part of this report. The importance of maintaining and servicing equipment is considered a key part of minimising outages and the ultimate use of the data. For very remote offshore locations, such as Haul Off Rock, it can be logistically impractical to conduct maintenance trips when weather conditions prevent safe access to these locations for large parts of the year. Gear modifications have since been made that may reduce the likelihood of data loss occurring at Haul Off Rock. This includes modifying the primary computer in each camera system to run directly on 12v power rather than on a 240v power inverter which had previously failed on multiple occasions.

Another key consideration is how the FoV provided by a camera relates to the areas used by ASLs at colonies. At Buller Island, one relatively small beach provided the only access on and off the island enabling the FoV to provide complete coverage of all animals entering/leaving. This was desirable in terms of representative estimates of abundance. However, even if the camera can be positioned to provide footage for the entire area occupied by ASLs, consideration also needs to be given to bias that can arise due to vegetation or 'grouped animals' which may obscure and make it difficult to count individual animals. The ability to identify the various ontogenetic classes of ASLs is also influenced by local topographic conditions. It was easier to identify animals on the beach in contrast to those animals that occupied dark boulders.

As with most trials involving innovative methods, aspects of this project went well while challenges were also encountered, particularly for the remote camera location at Haul Off Rock. The rather ambitious objective of providing near-real time footage and relative 18-month abundance estimates for all study locations was not met. At Buller Island, daily MaxN values peaked at 55 pups and 50 cows respectively, and the analysis provided an in-depth understanding of monthly variations in the abundance of pups and cows at this colony. The modelled peak in pup abundance obtained from the time series model at this location would assist in the scheduling of targeted BoG surveys. At Wickham Island, daily MaxN values for pups and cows were only 7 individuals each, while at Haul Off Rock the highest MaxN value was 3 individuals for pups and 8 for cows. Due to FoV constraints, the values for these latter two sites are likely to under-represent the number of ASL in each colony. Any continued camera monitoring, particularly for these South Coast locations, would benefit from an adjustment factor being applied to scale up the camera values to the total number of pups in the colony.

All time-series vision collected as part of this project is available for subsequent viewing (Objective 3). Therefore, the third objective of this study has been met to the largest extent possible. Examination of the footage revealed many incidental observations for ASLs including cow/pup associations, mating and breeding behaviours, and attempted predation. Several deceased ASLs were observed from the cameras during the study but no entanglements or injury attributable to fishing gear were observed in the footage, or

from site visits. Footage collected at Buller Island was available for staff to view live via a website. Within the context of monitoring ASLs and other wildlife, this extends the use of monitoring from “data capture” to “data capture and initiate targeted on-site surveys” for those select locations where BoG surveys are feasible. The technological steps required to achieve this are outlined in this report.

Implications for key stakeholders

The camera data collected throughout this project have provided contemporary information on ASL relative abundance for three colonies. Camera analysis could improve the cost-effectiveness of current BoG sampling, by tracking the stage in the reproductive cycle and informing the timing of BoG counts. This is particularly relevant for State and Commonwealth research and management agencies involved in the provision of scientific advice and research to support the ASL Recovery Plan.

The data generated from this study are also relevant to on-going attempts to better understand the fisheries-related risk to ASLs in WA. A recent ecological risk assessment for the Western Australian Temperate Demersal Elasmobranch Resource identified ASLs as being high risk (Watt et al., 2021). This was attributed to the potential for interaction with commercial gillnets, a lack of population modelling and fishery-independent data validation. The camera approach outlined in this study could be adapted to focus on those colonies that fall within the geographical range of current gillnet fishing activities. This would assist in interpreting the potential impacts of ASL catches assessed through the independent data collection program on the specific colonies. Other implications of this project are summarised in the report.

Recommendations

It is recommended that any future monitoring of ASL colonies in WA make full use of the outcomes of this study, and the digital library of camera images generated, to develop a sampling program capable of detecting changes in abundance.

Keywords

Digital cameras, novel monitoring tools, Australian sea lion, breeding colony

1.0 Introduction

1.1 Background

The Australian sea lion (ASL, *Neophoca cinerea*) is the only Australian endemic pinniped species and one of only three pinniped species that breeds on Western Australian (WA) beaches. They currently occur in colonies scattered around southwestern Australia and South Australian (SA) coasts, but records suggest that historically their range extended further eastward into Bass Strait (Ling, 1999). During the late 1800s ASLs, along with long-nosed fur seals (LNFS, *Arctocephalus forsteri*) with which they co-occur, were hunted for fur and oil (Ling, 1999). While the LNFS were the primary target of the sealing activity, comprising >95% of the trade, at least 4,000 ASLs were also harvested between 1790 and 1950. Commercial hunting for pinnipeds largely ceased in the 1920s when they became protected under legislation, but catches were recorded as late as 1950 (Ling, 1999). While populations of LNFS have recovered (Shaughnessy *et al.*, 2015), the overall number of ASLs has not, despite the far greater historical pressure on the former species. Estimates of the trajectory for ASL subpopulations have considerable uncertainty. Goldsworthy *et al.* (2021) concluded it is likely that ASL numbers will exhibit ongoing declines despite protection and conservation activities.

Primary extrinsic factors that are known threats to the population recovery include, disease, climate change and fishery bycatch (Goldsworthy *et al.*, 2021). Historically in WA, ASL incidental mortality by the rock lobster fishery was greatly mitigated by the introduction of sea lion exclusion devices in the early 2000s, after bycatch was identified as a key threat to the population (Campbell *et al.*, 2008). More recently, the majority of ASL bycatch has been attributed to gillnet fisheries that target sharks, noting that fishing effort in these fisheries has declined considerably from peaks in the 1990s (Braccini and Watt, 2021). A network of 33 gillnet exclusion zones came into effect in June 2018 to protect ASL breeding colonies. These zones were informed by a previous FRDC project that estimated interaction rates between ASLs and WA's temperate demersal gillnet fisheries (Hesp *et al.*, 2012). The zones range from six to 33 kilometres in radius, covering an area of 17,300 square kilometres (https://www.fish.wa.gov.au/PublishingImages/Maps%20and%20graphs/australian_sea_lion_gillnet_exclusion_zones_wa.pdf). No interactions between ASLs and the gillnet fisheries have been reported in Statutory Fishing Returns since the introduction of the exclusion zones (Watt *et al.*, 2021).

There are several aspects to ASL biology and ecology that may prevent its recovery. Firstly, the species displays an extreme level of female natal site fidelity (Ahonen *et al.*, 2016), whereby female pups return and reproduce at their colony of birth. Males are reported to disperse further, but have a range limited to approximately 200 km (Pitcher, 2018). This means that if ASLs are extirpated from a breeding site it is unlikely for that site to be recolonised from neighbouring colonies in the short term. Also, such high levels of fidelity fragment the broader population and reduce the level of genetic mixing between colonies along the maternal line. Secondly, ASLs are the only pinniped known to breed on a non-annual cycle that is estimated to be approximately 17.5 month in duration (Gales and Costa, 1997). This unusual periodicity means breeding alternates between opposite seasons in consecutive years and drifts over time between summer/winter cycles to autumn/spring cycles and back. This compounds with the reported female natal philopatry described above to produce neighbouring colonies with asynchronous breeding cycles, which could in turn reinforce the species' genetic fragmentation. The reported population

sub-division of ASLs that occurs over short distances (~60 km) has not been observed for other social marine mammals (Campbell *et al.*, 2008; Pitcher, 2018).

Breeding colonies primarily occur on islands but also on some remote sections of mainland coast. The current known breeding range extends from the Houtman Abrolhos Islands, WA, to the Pages Island, SA (Campbell *et al.*, 2008), spreading 80 known extant breeding colonies (Goldsworthy *et al.*, 2021). These colonies have been aggregated into 13 spatially segregated groups, which are used as a proxy for “metapopulations” (Pitcher, 2018). Within WA, 32 actively breeding colonies are known, grouped into six metapopulations. These colonies support just 18% of the total estimated ASL pup production with the remainder occurring in SA’s seven metapopulations (Shaughnessy *et al.*, 2011). Most of the WA colonies are considered very small producing <10 pups, however there are several medium size colonies in Jurien. From east to west the groups are Nuytsland (NUYT), Eastern Recherche (WASC1), Esperance (WASC2), Albany (WASC3), Jurien (WAWC1) and Abrolhos (WAWC2).

1.2 Legislated protection of Australian sea lions

The ASL was listed as Vulnerable under the Commonwealth Environment Protection and Biodiversity Act 1999 (EPBC Act) in 2005 (Department of Sustainability, Environment, Water, Population and Communities 2013). This listing was recently upgraded to Endangered under advice from the Commonwealth Threatened Species Scientific Committee (TSSC, 2020). The rationale for formally listing the ASL as an Endangered Species is in recognition of its reduced population size from historical levels, projected future decline and small sub-population sizes. The recent change in status was prompted by re-evaluation of the existing body of knowledge for the species and a more rigorous synthesis of new information, rather than a genuine deterioration in the species’ status.

Under state legislation, ASLs are protected species and are currently listed as Vulnerable in the Wildlife Conservation (Specially Protected Fauna) Notice 2018, Schedule 3.

1.3 Developing novel monitoring tools

The Recovery Plan for the Australian sea lion (ASL Recovery Plan) is a primary support document to the Commonwealth endorsed Listing Advice (former Department of Sustainability, Environment, Water, 2013). The Recovery Plan’s primary aim is to identify and direct the activities required to halt population decline and promote the species’ recovery. This is achieved through a series of direct mitigation and conservation actions specifically aimed at the major threatening factors as they are currently known. It is recognised in the document that for many colonies in remote areas there is insufficient knowledge to accurately estimate population sizes and trends. Recognising the lack of information, particularly for the small and remote ASL colonies in WA, the ASL Recovery Plan issues a clear mandate to “*Utilise emerging technologies such as aerial surveys, drones and remote cameras to provide a more comprehensive and complete assessment of population size and trends across the species range.*” More specifically, the plan goes on to recommend “*evaluat[ing] the feasibility and cost-effectiveness of remote camera methods for long-term monitoring of populations, particularly in remote locations*”.

The traditional method of monitoring the status of ASL colonies has involved a “boots on ground” approach (hereon “BoG”), whereby people physically visit the colonies, move among the animals, and take a visual census of the number of animals on shore (Goldsworthy *et al.*, 2008; Pitcher, 2018). This method is the most direct but does have some limitations, a major one being that ASLs spend a large proportion of their time at

sea. This means that colony counts only represent the portion of animals that are ashore at the time of counting. To address this, a “pup count” method is usually used due to that age class being land bound for the few weeks after birth. The number of pups is then extrapolated to give an estimate of the total size of that colony, using a conversion estimate based on estimates of age-specific survival rates from a well-studied SA colony (Goldsworthy and Page, 2007). This method relies on the census occurring within a very specific time, *i.e.*, after the pups are born but before they first go to sea which is believed to occur at around 5 months of age, and ideally should involve more than one count during this period. Due to their asynchronous and drifting breeding cycles, predicting those periods accurately can be challenging and mis-timing the visits may seriously bias the colony size estimates. Further limitations of the BoG approach include the physical logistics of multiple visits to remote and difficult to access islands, health and safety aspects of working in close proximity to large and defensive cows with pups, and potential disturbance effects on the animals. For readily accessible colonies, multiple visits within a breeding season can be made to provide a more accurate pup count estimate but this is usually impractical for remote and difficult to access colonies.

Several recent studies have employed Remotely Piloted Aircraft (RPAs / drones) to evaluate pinniped colonies (Adame *et al.*, 2017; McIntosh *et al.*, 2018). These innovative tools have resulted in successful surveys with accurate total counts of animals visible on land. An advantage of this method includes the repeatability of these surveys and the collection of a permanent record (digital images). Some have also integrated citizen science programs to deal with the associated data processing workload (McIntosh *et al.*, 2018). RPA surveys have also been used to assess ASL body condition, using morphometric measurements to non-invasively estimate fitness and health (Hodgson *et al.*, 2020). Nevertheless, these RPA solutions are largely limited to colonies that are nearshore and already relatively accessible. Limitations with current, readily available RPA technology and the Australian RPA regulatory environment make the use of long range and Beyond Visual Line of Sight (BVLOS) operations for routine monitoring challenging and potentially prohibitively expensive (Desfosses *et al.*, 2019). In addition, the typically cryptic behaviour of pups to sleep under rocks or vegetation (Shaughnessy *et al.*, 2011) means that RPA surveys are limited in the capacity to sight animals depending on the topography of the breeding site.

Fixed, land-based remote camera arrays provide a complimentary option to the traditional BoG method and the emerging RPA approaches to monitoring. Land-based systems have the potential to provide different types of data and address some of the limitations inherent in the previous two approaches. Such remote camera arrays have been used to monitor seabird nesting behaviour in Tasmania (Lynch *et al.*, 2015), and to estimate fishing effort in shore-based (Taylor *et al.*, 2018) and boat-based recreational fisheries across Australia (Hamer *et al.*, 2019; Hartill *et al.*, 2019; Lynch *et al.*, 2020). Analysis of footage obtained from a wireless camera has also been used to test the effectiveness of an established sanctuary zone for reducing human disturbance to ASLs at Carnac Island, WA (Kent and Crabtree, 2008). The advantages of remote cameras as a monitoring tool include the ability to collect continuous data to assist in interpreting daily, seasonal and annual trends (Afrifa-Yamoah *et al.*, 2021) and, potentially, to directly observe wildlife in adverse weather conditions, including the capture of footage at night (Taylor *et al.*, 2018). Remote cameras can also be used to observe animals in their natural state, without potential disturbance from human presence or overhead RPA flights (McIntosh *et al.*, 2018). With the correct system construction and connectivity, the ability to view real-time video footage collected

at remote locations can also inform other complimentary monitoring programs. However, as with any other newer monitoring tool, there is a need to better understand the potential advantages and limitations of camera monitoring for assessing the abundance of ASLs at remote offshore locations in WA.

One of the primary obstacles identified by Pitcher (2018) to the effective management of ASLs in WA is that the “estimation of WA populations has been hampered by difficulty of access and the need to determine accurately the timing of the breeding/pupping period, and requirement to conduct multiple counts during the breeding season”. Remote camera arrays could offer a viable solution to this problem in that; a) direct observations can be made and recorded continuously and b) they can allow researchers to fine tune their understanding of the periodicity of the breeding cycle to better time in-person observations. This is particularly valuable for remote colonies of ASLs because the asynchronous breeding times of colonies and narrow window of time when pups are land-bound makes it difficult for researchers to accurately determine the best time to conduct traditional pup counts. Furthermore, in theory, the successful determination of counts of ASLs from cameras could replace the need for in-person observations at remote colonies.

2.0 Objectives

The three objectives of this study were to:

- Evaluate the feasibility of using remote cameras as a method for monitoring the status of ASL colonies (Objective 1).
- Collect ASL counts (relative abundance) from study colonies over an 18-month period (full breeding cycle) to update understanding of their conservation status (Objective 2).
- Provide continuous time-series vision and ancillary *in-situ* data for other ecological or behavioural research in dynamics of WA ASL colonies (Objective 3).

Testing of the remote camera technique within the WA colonies will assist in determining the suitability of this method for on-going monitoring, in addition to more established techniques that are currently being used. Finally, the footage gathered will be made available for further use in research projects specifically identified in, or aligned with, the goals of the ASL Recovery Plan.

3.0 Method

3.1 Site descriptions

Three ASL breeding colonies were selected as study sites for this project. Each site was chosen to represent a diversity of colony size, island type and geographic location within WA to test the suitability and performance of the camera systems' robustness to the different environments.

The colony assessments contained in Pitcher (2018, Appendix 2) were also used in the selection of colonies to monitor. This included consideration of size and density of the colony, the "metapopulation" and island accessibility, as well as whether LNFS also occurred in the same area. All three colonies chosen were considered good candidates for monitoring efforts under the recommended monitoring framework for ASLs (Pitcher, 2018).

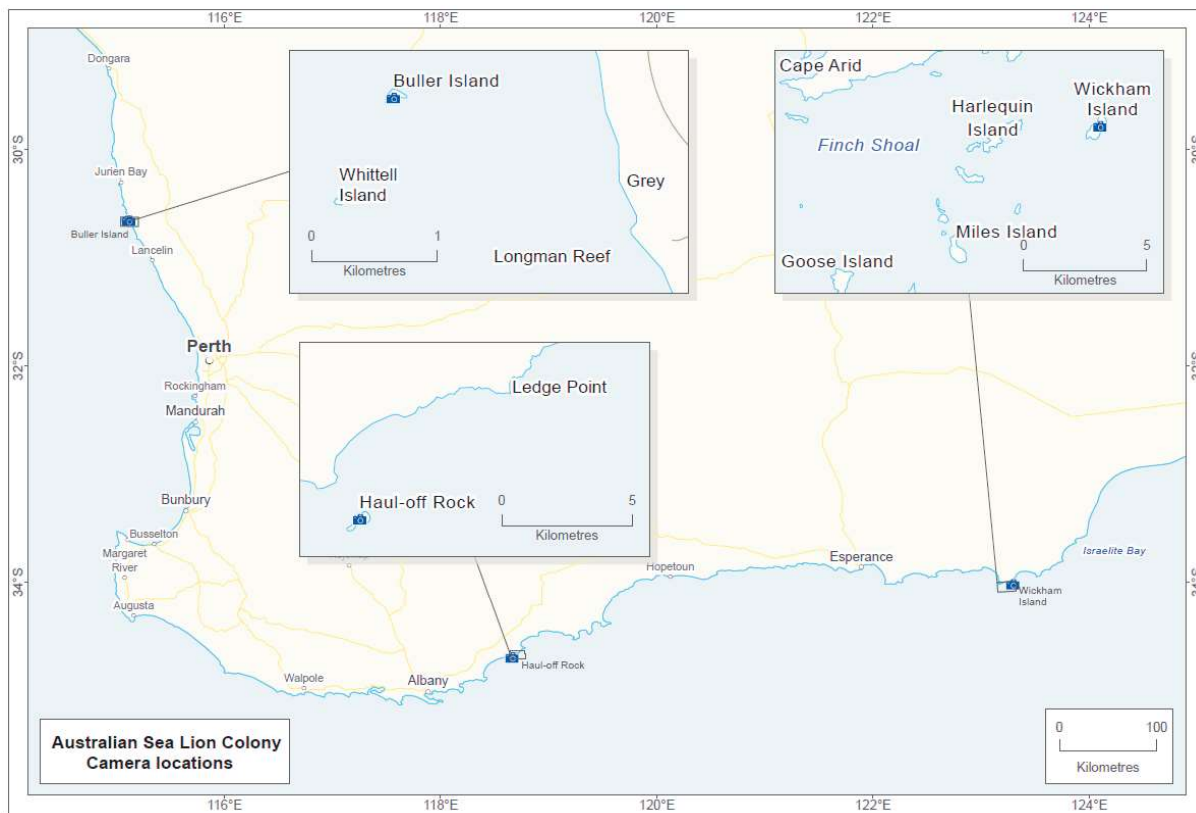

Figure 1. Map of Western Australia indicating the three ASL colonies chosen for remote camera monitoring.

3.1.1 Buller Island

The first camera site was Buller Island, located off the west coast near the settlement of Grey, WA (Figure 1). This location was chosen to represent a west coast colony and is considered by Pitcher (2018) to be part of the WAWC1 metapopulation. The ASL population size at this colony is considered to be fairly large for a WA colony. A 17 km gillnet exclusion zone surrounds the colony. Twelve surveys have been completed at this location over the past 30 years (Goldsworthy *et al.*, 2021), a greater number of surveys than for many other WA colonies. These surveys have provided a metric of population size and reproductive capacity. Australian sea lions are the only pinniped known to regularly use this island. The coastline is comprised of a predominantly limestone cliff with one

relatively small beach providing the only access on and off the island (Figure 2). This topography acts as a natural bottleneck for the animals as they move from the ocean to the vegetated centre of the island and consequently the colony is very compact. The beach itself is also used as a protected haul out area by the animals. This relatively small stretch of beach was able to be covered effectively by a single camera installation site (with two cameras) at a suitable elevated location (Figure 2).



Figure 2. Buller Island foreshore showing camera array (refer to yellow box).

3.1.2 Haul Off Rock

The second camera site was Haul Off Rock, a moderately large colony by WA standards (Pitcher, 2018) that has only been surveyed four times over the past 30 years. The remote island is located 80 kms north-east of the regional centre of Albany on the south coast of WA. A 13 km gillnet exclusion zone surrounds the colony. Australian sea lions on the island are considered to be part of the WASC3 metapopulation (refer to Figure 12 in Pitcher, 2018). The island itself is a large, weathered granite dome with variable levels of access for around half of the coastline. The coastline is either smooth granite slope which grades into steep cliff on the seaward side, or structurally complex granite boulder field (Figure 3; Figure 4). The ASL colony at this site is spread across most of the island, including the higher areas of the dome, smooth slopes, and the coastal boulder fields. The region is also inhabited by the LNFS, forming a mixed-species pinniped assemblage. However, LNFS were only observed very close to the water's edge during this study (Figure 5). The large size of the island and the long stretches of traversable coastline meant that that the single camera array (with two cameras) did not cover all access points on and off the island.



Figure 3. Northern face of Haul Off Rock from the water.



Figure 4. View to the west from half-way up the island dome at Haul Off Rock.



Figure 5. Long-nosed fur seal cow and pup observed near the water's edge at Haul Off Rock.

3.1.3 Wickham Island

Wickham Island is located 130 km east of Esperance in the remote Recherche archipelago. A 14 km gillnet exclusion zone surrounds the colony. The ASL colony on this island is part of the WASC2 metapopulation (Figure 12 in Pitcher, 2018). It is considered small, with low pup production (Pitcher, 2018), based on two admissible surveys conducted between 1989 and 2014 (Goldsworthy *et al.*, 2021). The island is completely inaccessible from the seaward side; however, long stretches of the lee side can be accessed by pinnipeds (Figure 6). Human access to the island is challenging due to its remote location and the small landing area is navigable only in favourable weather conditions. The lee side of the island is made up of patches of beach and limestone rock while the centre of the island is densely vegetated. The ASLs occupy all parts of the island, using the beach areas as haul out areas as well as to traverse to the interior. This colony was expected to be comprised of only ASLs however LNFS were observed here during this project (Figure 7). As for Haul Off Rock, the configuration of the island meant that that a single camera installation site (with two cameras) could not cover all access points on and off the island or haul out beaches.



Figure 6. View from the northern point of Wickham Island looking southwest towards Gulch, Owen and Middle Islands.



Figure 7. Long nosed fur seal at Wickham Island.

3.2 Camera system

A camera system is made up of a series of components that are designed to capture and store imagery. In some instances, this imagery can also be transmitted from remote locations, such as an ASL colony, to a regional office. Numerous hardware (camera, computer, power supply, modem, antennae, external hard drives), software (capturing video frames and pushing to a centralised server) and data storage options exist for any camera system. A more technical account specific for this project is outlined below. Where specific hardware products are mentioned, these were selected as the most cost-effective from several products examined at the commencement of the project. However, other alternatives should be examined for technological advancements.

The Department has almost 20-years' experience in remote camera monitoring for recreational fisheries (Blight and Smallwood, 2015; Hartill *et al.*, 2019). This expertise was applied in the design of camera systems in the current study to provide the best opportunity of monitoring ASLs at the three challenging locations.

3.2.1 Hardware

The specifications and model numbers for the camera system's components are provided in Table 1, a schematic of the configuration is provided in Figure 8, and an image of the internal components are provided in Figure 9. This technical information is provided as a guide for other researchers, rather than being an endorsement of a specific brand.

Table 1. Specifications and model numbers of the electronic components used in the camera system arrays.

	Component	Specifications
Primary installation		
	Primary battery	2x Pure Energy 12V 130Ah AGM Deep Cycle Battery
	Solar Panels	2x LG NeON2 330W
	Charge controller	SCC020050200 : Victron BlueSolar MPPT 100/50 50Amp Regulator
	240v power inverter	Powerhouse 600W 12VDC - 240VAC Power inverter
	Computer	Apple Mac Mini: 2.6GHZ/8GB/1TB-AUS - MGEN2X/A
	4G modem and router	Netgear AC2300 nighthawk
	External 4G antenna	NetComm ANT-0026 4G LYTE MiMo antenna
	PoE injectors	PoE injector 24v output / 48v output
	Primary camera	Mobotix M16A Allround camera, H264
	Primary camera sensors	Mobotix MX-SM -XXX-PW6MP series: D43/N43/D65/N65/D135/N135
	Secondary camera	Hikvision DS-2CD2H85FWD-IZS
	Wireless bridge	Ubiquiti Nanostation 5AC
	Storage	WD elements USB3 PHDD 4TB
Secondary installation		
	Battery	Drypower 12v 80Ah SLA battery
	Solar panel	generic 150w panel
	Modem	TP-LINK Archer MR200 AC750 Dualband 4G router
	Long-range wireless bridge	Ubiquiti PowerBeam-5AC-ISO-Gen2
	Wireless bridge	Ubiquiti Nanostation 5AC
Extra components		
	Network switch	Netgear GS105 Prosafe Unmanaged Gigabit switch

Power was generated by a pair of 350W solar panels, which charged a pair of 130Ah deep cycle batteries via a 50A solar charge regulator. This provided sufficient power for all the system components and enough reserve battery capacity for several days of low solar collection in the event of poor weather. Power was distributed from the batteries either directly in the case of 12v components, through a 600W power inverter for the single 240v component, or through PoE (Power over Ethernet) injectors of the relevant voltage to other components.

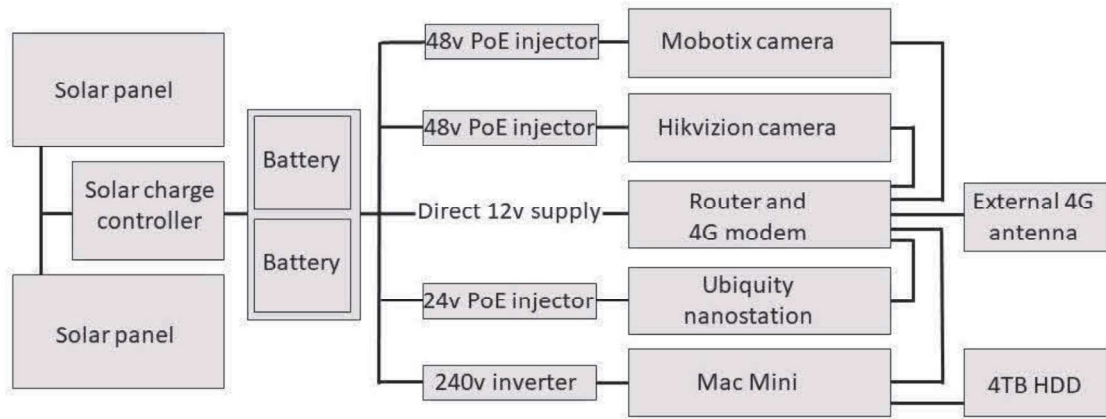

Figure 8. Schematic of camera components.

Data connectivity within the system was maintained by a 4G router (Netgear AC2300 nighthawk). This unit required 12v and was powered directly off the battery. The router also maintained remote connectivity via the 4G cellular network when sufficient signal strength was present at the site. To maximise signal strength to the 4G network, a MiMo antenna was connected directly to the antenna ports of the modem.

The primary camera used in the installations was a Mobotix (Mobotix M16A, 6MP) with one daytime lens and one low light lens, which the camera automatically switched between according to ambient light levels. Lenses were interchangeable on this model and lens pairs were chosen based on focal length to match the field of view required at each site. A secondary camera (Hikvision DS-2CD2H85FWD-IZS) was also installed as an alternative to the primary camera on all three camera systems. This camera had a variable zoom lens enabling it to zoom in on the area of interest but did not have pan or tilt capability and provided a fixed wide field of view. Both cameras were powered by 48v PoE injectors and connected directly to the 4G router.

An Apple Mac Mini was used as the primary computer in each system. It was powered by a 240v/600W power inverter and networked to the rest of the components through the router. In addition to the computer's 1TB internal hard drive, an external 4TB hard drive was attached as backup and extra storage.

The final component was a wireless network bridge station (Ubiquity nanostation) which was installed for short-range remote communications. This unit allowed high-bandwidth communication to the remote stations from the shore. This was used for data redundancy backup to a base station, or for remote access when 4G communication was slow or unreliable.

The solar controller, batteries, PoE injectors, router, computer, and hard drive were housed in a locked, weather-sealed galvanised steel enclosure (Figure 9). The cameras, solar panels, 4G antenna and network bridge were attached to a purpose-built metal frame and the central system enclosure was stored underneath (Figure 10, Figure 11, Figure 12).

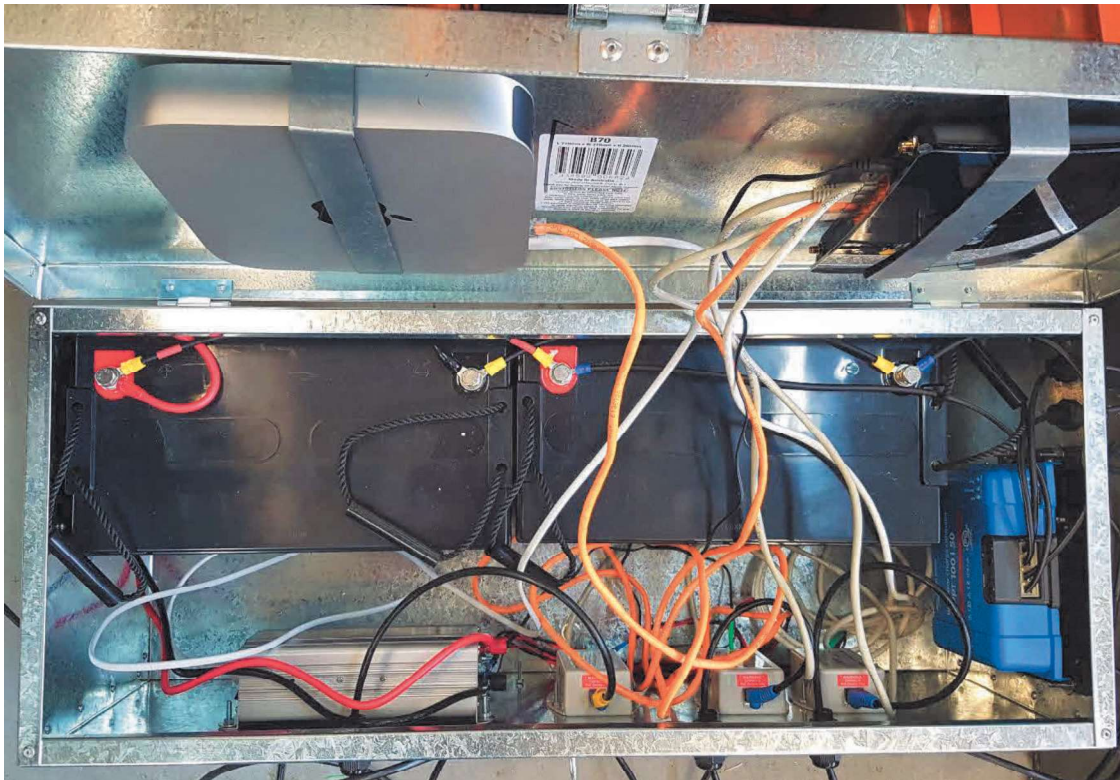

Figure 9. The camera system component arrangement within the secure enclosure.



Figure 10. Camera array on Buller Island.



Figure 11. Camera array on Haul Off Rock.



Figure 12. Camera array on Wickham Island.

The systems were designed with an independent “base station” which was situated on the mainland close to the island colony and was connected via a wireless link (Figure 13). The computer system was designed to automatically back up the timelapse files to a hard drive at the base station and to continue to overwrite the oldest backup files on the hard drive at

the main system array. This provided three redundant locations for data (Mac Mini hard drive and 2x external hard drives) at two separate geographical locations. The intention was to retrieve the data at the mainland locations if data collection was required and weather was unsuitable for visiting the island. This process worked efficiently at Buller Island where the data link was the most stable; however, system maintenance visits were still required at the other two islands, so the base stations were used for data redundancy rather than as a data retrieval point.

As none of the three systems could be linked directly to a hardwired network either directly or via the base stations, all remote communications were conducted over 4G signal. Due to the size of the data files generated these could not be effectively transferred over the 4G connection. Therefore, the most efficient means of data transfer was to manually retrieve the backup disk from the main array or base station during a maintenance visit. Hard drives were swapped for a blank drive on location and upon return to the office, the full drive was emptied into a central data storage RAID, formatted, and put back into a rotation as a replacement blank drive.



Figure 13. Mainland base station for Wickham Island at Cape Arid.

In addition to general repairs and replacement of components, the following modifications were made to the systems throughout the project to increase the stability and reliability of the installations:

1. Secondary installations were created on the mainland close to the colony islands and connected via the wireless bridge units. These secondary installations comprised a router, back up hard drive and paired wireless bridge unit. Where 240v power was available the installations were run directly, while at Wickham Island a small solar panel/charge controller and battery were used. These systems were

intended to provide an easy means to contact the island in times of inclement weather as well as a continuous data redundancy in the event of complete system failure on the island. The wireless bridge units proved to be adequate for the Buller Island communication; however, the signal strength was insufficient at Haul Off Rock and Wickham Island. The units were upgraded to stronger signal models (Ubiquity Powerbeam) and the placement at Haul Off Rock was changed to one higher up the slope away from the main installation (Figure 14).

2. One of the least reliable components in the system proved to be the 240v power inverter that ran the computer. This is despite the same model inverters running reliably in the Department's similar boat ramp camera systems. This issue was solved through modifying the Apple Mac Mini computers to run directly on 12v power rather than on 240v. This eliminated the need for the inverter component but resulted in the loss of data.



Figure 14. Extend range transmission unit.

3.2.2 Camera maintenance and data retrieval schedule

The project was designed to record the colonies for 18 months to encompass one full breeding cycle for this species. Recording began in each colony at different times due to the varying times for suitable weather windows to transport and construct the camera arrays on location.

Maintenance visits to the camera arrays were scheduled approximately every three months for routine maintenance such as data download, lens cleaning and inspections for water ingress and corrosion. Maintenance visits were also performed when malfunctions were detected or suspected to have occurred (e.g., camera movement or loss of communication).

Although a regular schedule for maintenance was planned, access was heavily weather dependant since landing on the islands was safe only under certain conditions. This was particularly the case for the Haul Off Rock and Wickham Island locations. Maintenance

visits were also impacted by emerging research priorities during the research project which limited field capacity at certain times.

3.2.3 Software and camera configuration

To generate time lapse footage, both cameras on each system were programmed to take a time-stamped still image (of 3840 x 2160 pixels) every two or three seconds and record directly to the computers 1TB internal hard drive. Every hour, the computer compiled the last hour's collected images for each camera into video files using third party software (Ben Software, 2016).

Approximately 1200-1800 images that represented 1 hour of real time were compiled to create a 4K video file slightly less than 2 minutes long. Once compiled, the computer backed up the video files to the internal and external hard drive. Software configuration was similar to that described in Blight and Smallwood (2015).

The initial project proposal specified that data recording would include continuous video, timelapse and single frame images to determine the most appropriate approach for data collection. Early in the trial process all three types of data recording were undertaken. It was determined that the most efficient and best quality data could be collected using time-lapse compiled from still images taken at intervals of between 2 and 3 seconds (See Results). Therefore, this protocol was followed throughout the remainder of the project. Although time lapse footage was collected continuously, i.e., for 24 hours each day, the usability of the night-time footage varied among sites and times. As a result, only daytime footage was able to be consistently processed.

Motion sensor triggering is within the existing capability of the camera system and the option to enable this function was evaluated at the start of the study. Examination of the triggered images revealed that the motion sensor was an unreliable trigger due to the high amount of movement in the ambient environment. Additionally, the study area at Buller Island was very often occupied by ASLs so the motion sensor would have been triggered almost constantly. Therefore, it was considered an appropriate compromise to take continuous timelapse footage to gain consistency of timing and data continuity at the potential expense of slightly more data storage and processing.

Subsequent analysis was based on the images obtained from the Mobotix camera (primary camera) as the image resolution proved to be superior. In particular, the secondary camera at Haul Off Rock was affected by salt buildup on the lens (refer to Results, Performance under different environmental conditions). During one period of system malfunction at Haul Off Rock, the computer became unresponsive and the camera system was remotely reconfigured to store images directly on the Mobotix camera's internal data storage. Under these circumstances, the image interval was increased to 10 seconds and the resolution remained unaltered to make the best use of the limited in-camera storage space. However, due to ongoing storage space limitations, the SD card was then reconfigured to record one still image every 20 minutes at lower image resolution (1536 x 1024 instead of 3072 x 2048).

3.3 Video sampling design and animal classification

3.3.1 Video processing

Two video processing protocols were developed and trialled for reading data from the footage. These were termed “video” and “still” read techniques. Each technique was found to have strengths and drawbacks, and their appropriateness for future projects would depend on the context to which they may be applied.

Reading protocols were developed to fit the specific FoV constraints of each location. To facilitate consistent reads throughout data processing, boundaries were drawn on the FoV to indicate whether animals were to be counted or not (Figure 15 and Figure 16). Within the boundary lines, it was possible to identify, sex and classify animals, excluding any blind spots or water. Note that due to changing water levels related to tide, cross-shore accretion or erosion, the FoV was not a constant area, but was a consistent measure of occupiable area for the ASLs at Buller and Wickham Islands. As the camera at Haul Off Rock was focussed on sloping granite, the FoV was constant. The variability in the boundary lines, particularly the water line, is demonstrated at Buller Island. Figure 17 depicts a situation where the beach profile was very short, and Figure 18 where the beach profile was very long.



Figure 15. Still image from the Buller Island camera showing the boundaries of the field of view, including the sections of the boundary used in the "video read" analysis.



Figure 16. Still image from the Haul Off Rock camera showing the boundaries of the field of view used in the "video read" analysis.

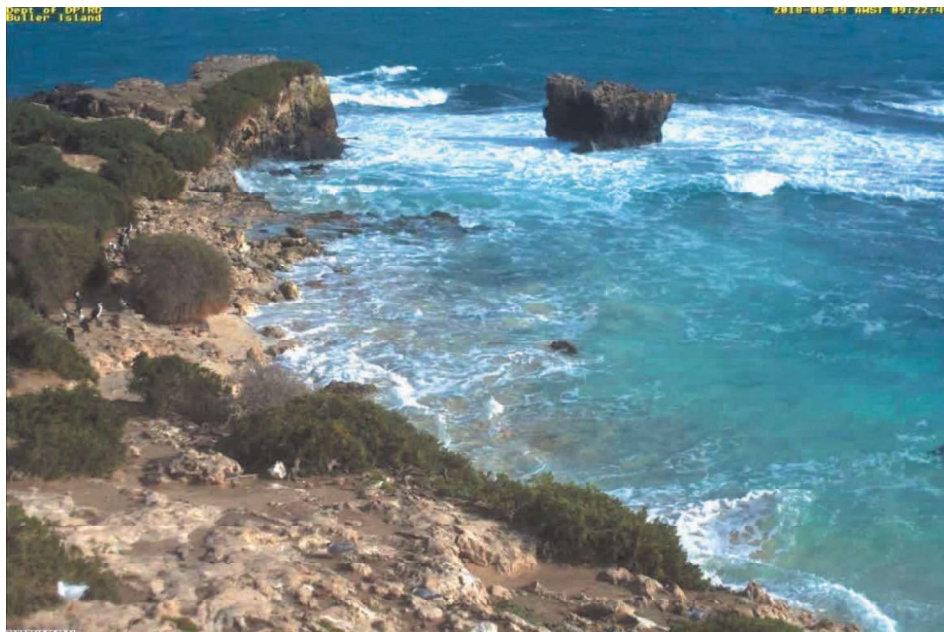

Figure 17. Buller Island showing a very short beach profile.



Figure 18. Buller Island showing a very long beach profile.

3.3.1.1 Video read technique

Time lapse videos were organised into one-hour blocks. At the beginning of each hour of video, an instantaneous count was performed on the initial frame of the file. The total number of ASLs in that frame was recorded for each sex and class (refer to Animal Classification). Subsequently, every animal entering or leaving the field of view was assigned: time (to the nearest second), sex, class and direction of movement (e.g., “+1” equals one animal entering or “-1” equals one animal leaving the field of view, adapted from Taylor *et al.*, 2018). For each record, the “location” where the movement occurred (i.e., where an animal came in or out of view) was also noted. This resulted in detailed data where every animal movement across a boundary line was recorded. Hourly counts were also used to “truth” the detailed individual in-and-out data to avoid propagating single errors through the entire day’s dataset.

3.3.1.2 Still read technique

The still video read technique used the same footage and boundaries as the video read including:

- time lapse files
- spatial boundaries of the FoV
- animal classifications

The time lapse footage was initially analysed during “readable daylight hours”. This was defined as from the moment the camera switched from the night time lens to the day lens until it switched back. As such, the duration of readable daylight hours changed throughout the study period as the day length became shorter or longer with the seasons or weather conditions. For example, day length at Buller Island was approximately 10.75 hrs near the winter solstice and 14.75 hrs near the summer solstice. This protocol was maintained at Wickham Island and Haul Off Rock footage; however, the large numbers of animals within the FoV in the Buller Island footage made full processing time prohibitive. Analysis on a

limited data set at Buller Island was conducted to determine the period of peak usage during a daily cycle. This was determined to be between 13:00 and 17:00 daily (see Figure 27). Processing of footage at Buller Island was then restricted to this peak period for the remainder of the footage collected. A standard operating procedure was developed for reading the data. This ensured consistency in counts between readers and detailed the protocols for dealing with unreadable footage due to poor weather, glare, or camera condition.

Single frame instantaneous counts of sea lions were performed every 15 minutes on the quarter hour throughout the day (:00, :15, :30, :45) at Wickham Island and Haul Off Rock, and from 13:00 to 17:00 at Buller Island. Although the data generated using this technique are not as dense as from the video read technique, it is considerably faster and easier to extract than from the footage, particularly when many animals are within the FoV. While counts were only made at the specified frames, timelapse video of the surrounding frames could be played to glean behavioural cues and correctly classify classes of the animals.

3.4 Animal classification

For both video and still read techniques every effort was made to accurately identify ASLs into the following demographic classes: pup, juvenile, cow, sub-adult male (SAM) and bull (Figure 19). This was to test the camera systems' suitability to create subsets of data that could potentially inform multiple research objectives.

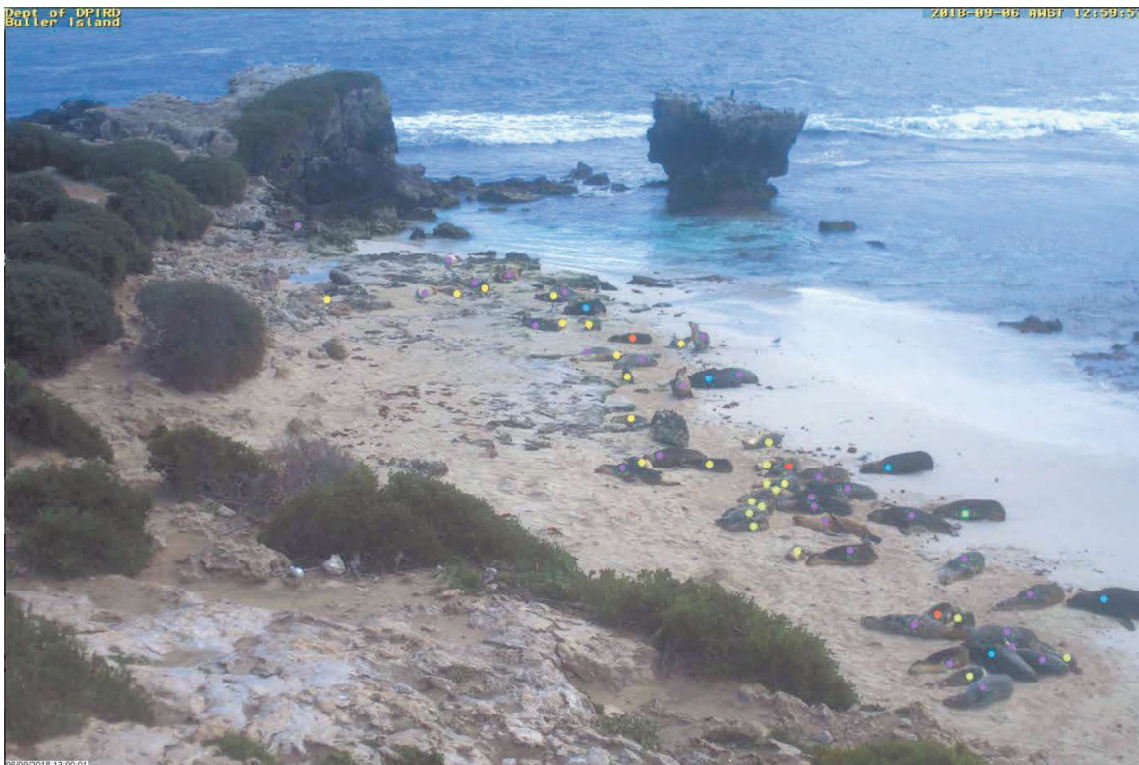

Figure 19. Still frame from Buller Island footage showing ASLs classified into demographic classes. Yellow = pups, pink=cow, blue = bull, green= sub adult male, red = unknown.

3.4.1 Pups

Pups were classified primarily based on size (visual estimate), but behavioural cues such as nursing activity were also used to determine this class (Figure 19, Figure 20).

The performance of the camera systems to count pups was particularly important because that demographic class has been used for BoG counts and is what is needed for a population abundance estimate. In a BoG survey, coat colour is a metric typically recorded as a measure of the approximate age of the pups (e.g., black, brown, moulted, lanugo). This coat state could not be consistently interpreted from the footage and was not recorded as a metric in this reading protocol. As such, the classes of newborn pup (*sensu* Shaughnessy *et al.*, 1994; Campbell, 2003) and larger more mobile pups were combined into a single class. This contrasting definition of what was included in the pup class means that the BoG and camera counts are not directly comparable, the implications of which are outlined in the Discussion. Nevertheless, comparable information can be drawn from both data sets, including the date at which the first black pup was positively identified.

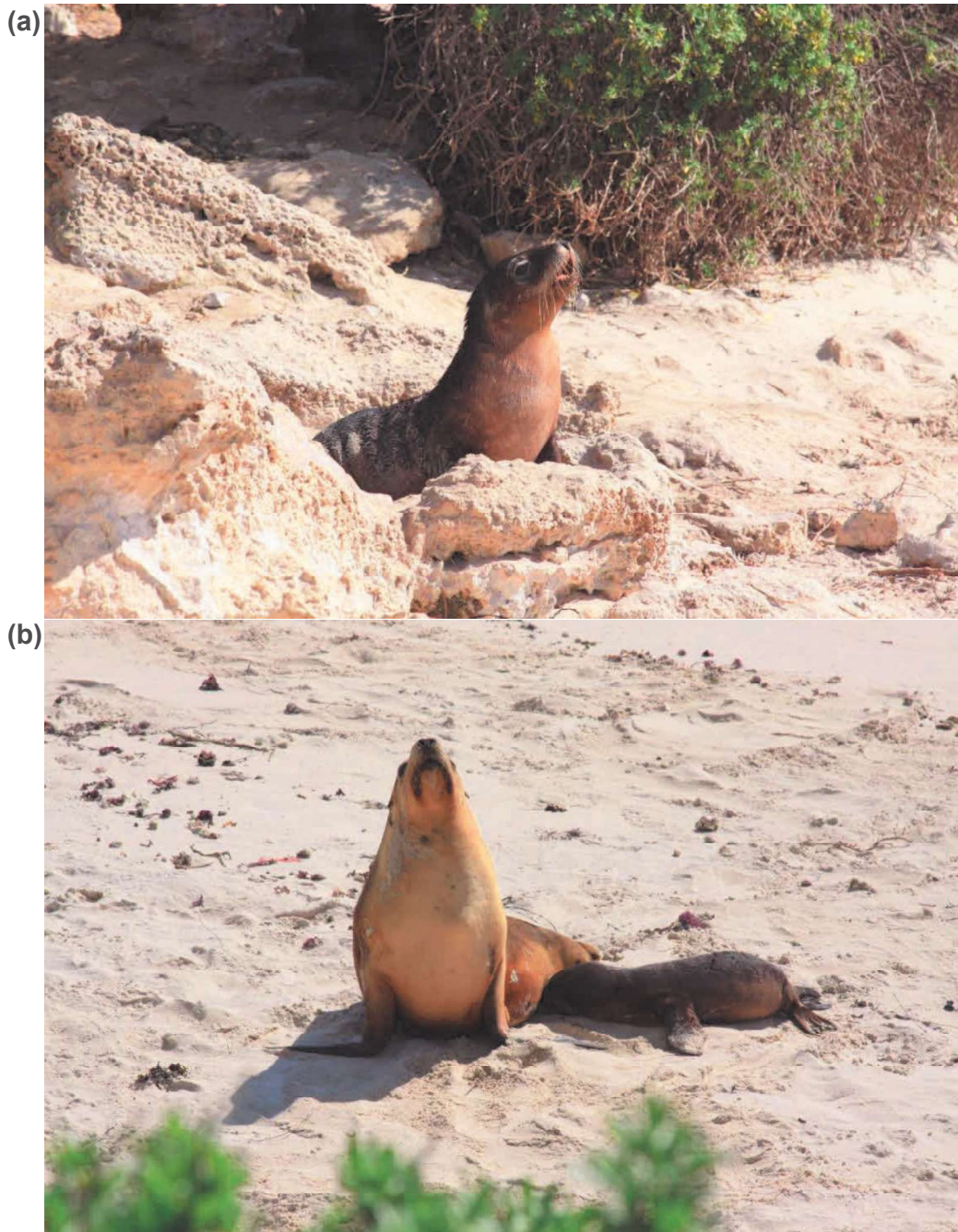

Figure 20. Images from Buller Island showing (a) ASL pup and (b) ASL cow nursing a pup.

3.4.2 Juveniles

This demographic class includes both males and females which have the same colouration as cows but are smaller in size (Gales *et al.*, 1994; Campbell, 2003). On the footage, the males and females are indistinguishable. The males have not yet developed any of the discernable sexual characters used to discriminate them, including the larger body size, white crown, or darker coat. Juveniles are not sexually mature, so females would not be nursing pups.

3.4.3 Cows

Cows are mature females and are of a similar size to large juveniles but are recognizable by the presence of a pup that is still nursing (Gales *et al.*, 1994; Campbell, 2003). The female coats are typically fawn coloured with a lighter ventral surface but may be darker depending on molt state. This class and late-stage juveniles are often the most difficult to discriminate.



Figure 21. Image from Buller Island; three cows are visible on the beach in the middle of the picture, one bull is visible on the beach on the right-hand side of the image.

3.4.4 Subadult males (SAMs)

Subadult males are immature males. They have begun to develop the characteristics of bulls such as larger size, however they are smaller than mature bulls and are yet to develop a white crown (Figure 22 and Figure 23). When observed in the footage, SAMs do not typically display guarding behaviours and are often chased away by mature bulls.



Figure 22. Image from Wickham Island showing a subadult male.

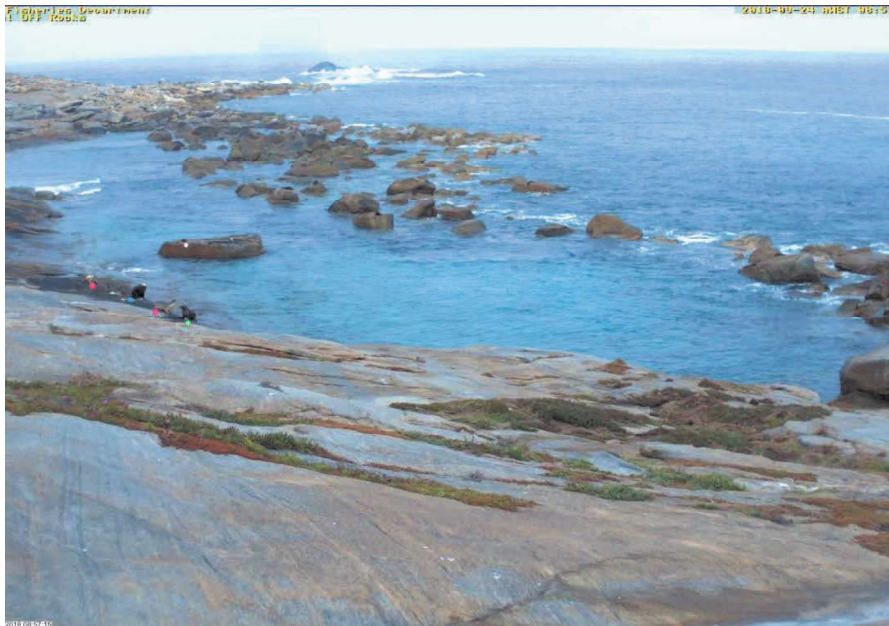

Figure 23. Still frame from the Haul Off Rock footage showing a bull (blue circle) and a sub-adult male (green circle).

3.4.5 Bulls

Bulls are often easily distinguishable from the other demographic classes as they are much larger than cows (Figure 24). They also have a very dark coat and a white crown, both of which are usually visible on the footage (Gales *et al.*, 1994; Osterrieder *et al.*, 2017). Behavioural cues can also be discerned during breeding periods where bulls will actively fight with other bulls and display guarding behaviour towards receptive females.



Figure 24. Footage of ASL bulls taken at (a) Wickham Island and (b) Buller Island.

3.4.6 Unknown

Where an individual could not be confidently assigned to a demographic class it was recorded in the “Unknown” class. This was to preserve confidence in the integrity of the other classes whilst also ensuring the total number of individuals was accurately recorded. Additionally, this facilitated evaluation of the camera system in terms of how often and under what conditions ASLs were able to be accurately classified from the footage. If an animal initially recorded as unknown could later be confidently classed, the reader propagated the record of that individual as far back as it could be reliably tracked (Osterrieder *et al.*, 2015).

3.4.7 Long nose fur seals

As the focus of this study was on ASLs, data on LNFS were not recorded for all locations. However, data pertaining to any LNFS identified from the footage at Haul Off Rock were recorded due to the smaller number of images obtained for this location.

3.5 Mortalities and entanglements

One of the primary concerns for the conservation and recovery of ASLs is their mortality due to entanglements or injury due to interactions with fishing gear. The standard operating procedure developed specified that any observed mortalities and any discernible entanglements should be noted for all camera locations. This included any fishing gear such as ropes or nets as well as any artificial marine debris. None were observed during the project, including on those site visits made for camera maintenance purposes (see also Results).

3.6 Other biological observations

Qualitative observations were made of one-off or potentially informative events during processing. These included date of the first black pup appearing, mating behaviour, predation, other social behaviours and other observations of other species (LNFS, birds etc).

3.7 Analysis and modelling

3.7.1 Preliminary analysis of “video” read data

The video read protocol was trialled as an adaptation from a similar camera project (Taylor *et al.*, 2018). The movements of ASLs in and out of the field of view at Buller Island over a 14-day period were recorded from timelapse footage. This resulted in extremely “high-density” data. Due to the finite resources and timeframe, further processing of footage using this method was determined to be impractical, and unnecessary for the specified aims of the project. The decision was therefore made to use the “still read” method for the remainder of the footage (see below). Preliminary visualisations of the video read data set are presented in the results (Figure 25) to demonstrate the scope of this type of data for future research that could include more quantitative analysis.

3.7.2 Analysis and modelling of “still” read data

The data obtained using the still read protocol was considered the most appropriate for the second objective of this study (i.e., collect ASL counts over an 18-month period) and formed the basis of subsequent statistical modelling. This modelling was based on maximum daily counts (MaxN) by demographic class at each camera location. The use of MaxN has been widely applied as an indirect measure of abundance in other ecological studies and avoids ‘double counting’ the same animal on a given day (e.g. Langlois *et al.*, 2020).

Initial data exploration was conducted to determine whether the data displayed trends consistent with the non-annual breeding cycle known for ASLs. The non-annual breeding cycle is a primary characteristic of this species and detection of this periodicity should be possible from the data collected. Trends were examined for both pup and cow classes.

The choice of an appropriate model was based on knowledge of seasonal trends of pup cycles, the time series of daily maximum counts, and the lack of multiple cycles in the data. A sinusoidal model was fitted to the time series of pups and cows. This was used to estimate trends and the following associated parameters: period, amplitude, phase and y-

offset of cycle for investigation of intra-annual trends of pups and cows. For modelling, the count data for pups and cows were considered to potentially conform to one of two alternative distributions (Poisson and negative binomial).

The sinusoidal model fitted was given by

$$\hat{Y}_{d,i} = C_d + A_d \sin\left(\frac{2\pi}{\omega_d}(i + \varphi_d)\right)$$

where $\hat{Y}_{d,i}$ is the estimated maximum daily count of the d th demographic category (i.e. pups or cows) for the i th day since the commencement of recording, C is a constant defining a mean level, A is an amplitude for the sine wave, ω is the period and φ is the phase. ε_i is the observation error (assuming either a Poisson or negative binomial distribution) for the observed counts $Y_{d,i}$ of each demographic category on each day. The sinusoidal model was fitted by minimising the negative log-likelihood associated with the count data. When assuming a Poisson distribution, the negative log-likelihood, λ , was calculated as

$$\lambda = -\sum_{i=1}^n \log_e \left(\frac{\hat{Y}_{d,i}^{Y_{d,i}} \exp(-\hat{Y}_{d,i})}{Y_{d,i}!} \right)$$

Alternatively, when assuming a negative binomial distribution, the negative log-likelihood, λ , was calculated as

$$\lambda = -\sum_{i=1}^n \log_e \left(\frac{\Gamma(r + Y_{d,i})}{Y_{d,i}! \Gamma(r)} \left(\frac{r}{r + \hat{Y}_{d,i}} \right)^r \left(\frac{\hat{Y}_{d,i}}{r + \hat{Y}_{d,i}} \right)^{Y_{d,i}} \right)$$

implemented via the *dnbinom* function in R, where Γ is the Gamma function and r is the inverse of the dispersion parameter θ of the negative binomial distribution.

The parameters were fitted in log space to ensure that the back-transformed variables remained positive. The sinusoidal model was fitted using the *nlminb* function in the R software package (R Core Team, 2018). Estimates of the derived variables C , A , ω and φ for each demographic category were calculated by back-transforming (exponentiating) the fitted parameters. Standard errors for the (back-transformed) derived variables, were assumed to be normally distributed and calculated based on the estimated covariance matrix using the delta method based on a first-order Taylor series approximation (Seber, 1982). These standard errors were used to derive approximate 95% confidence intervals for the back-transformed variables.

Models employing the Poisson and negative binomial distributions were compared using the second-order Akaike's Information Criterion (*AICc*) (Burnham and Anderson, 2002). The *AICc*, which accounts for the number of parameters relative to the number of data points, is calculated as

$$AICc = -2\lambda + 2k + \frac{2k(k + 1)}{N - k - 1}$$

where k is the number of parameters and N is the number of data observations. The model with the lowest *AICc* was taken as the most parsimonious model best supported by the data. In addition to comparing models with different error distributions, preliminary analyses based on *AICc* were undertaken to compare models with one or more common parameters for the two demographic categories. These results indicated that the fully saturated model (i.e., with no parameters shared between demographic categories) was

the most parsimonious model given the data. In this report, results are only presented for the fully saturated models.

Confidence intervals and prediction intervals for the fitted sinusoidal curve were calculated using a parametric bootstrapping analysis. The estimated parameters of the sinusoidal model and estimated variance were employed to produce 1000 random samples of pup and cow count data on the days where observations occurred. The sinusoidal model was fitted to each of the 1000 random samples and the resultant parameter estimates used to produce 1000 estimates of the mean counts of pups or cows on each of the days with observations. The 95% confidence intervals of the mean counts of each demographic category for each day were taken as the lower 2.5th percentiles and upper 97.5th percentiles of the estimated mean counts for that day. To produce approximate 95% prediction intervals, each of the 1000 estimates of the mean count (of each demographic group) for each day, along with the estimated variance, were used to generate a single random count. The 95% prediction intervals were taken as the lower 2.5th percentiles and upper 97.5th percentiles of the random count data.

3.7.3 Comparison between camera and BoG data sets

Maximum daily counts of pups from the Buller Island camera data were compared with counts obtained from the BoG dataset, the latter of which contained both historical and contemporaneous counts of pups. It is acknowledged that the two data sets are not directly comparable due to the following:

- The definition of the pup class is different between the two methods. The BoG approach counts newborn and moulted pups because they are understood to be primarily land-bound. The camera data included larger, later-stage pups within the scope of “pup” as they were often difficult to distinguish on the footage.
- Both methods have different sightability biases. For some colonies, the BoG approach is unable to accurately count the larger pups because the process of counting makes them flee into the water, while the cameras do not have a disturbance factor.
- The camera data is unable to account for small pups that are hidden on the interior of the island. During BoG surveys, staff can search among the high-complexity vegetation to count small pups.
- It is only feasible to conduct BoG counts on a limited number of days per breeding cycle, whereas the remote camera method enables counts to be taken on a vastly higher number of days.

The comparison between the two datasets is provided to assist in comparing the types of information the two methods provide, how these can be used, and possibly integrated in future studies. The comparison was restricted to Buller Island for the following reasons:

- Buller Island is the only site with sufficient data available to make a comparison between the camera and BoG data (i.e., lack of BoG data for Wickham Island and Haul Off Rock).
- The FoV at this location covered almost the entire beach, providing the best opportunity to obtain as complete a count as possible.

Historical data from pup counts at Buller were also sourced from the published literature (supplementary data for Goldsworthy *et al.*, 2021), comprising 12 counts between 1989 and 2019.

4.0 Results

4.1 Developing an appropriate read technique

It was necessary to develop a “fit for purpose” method for manually reading the camera images and extracting the required data on ASLs to address the first objective of this study. Unlike BoG surveys, where the capture of data is limited to the number of on-site surveys, remote cameras can provide on-going, long-term data. In this instance, the researcher can control how and when imagery is read, depending on the objectives of the study and fiscal constraints. The suitability of various approaches of reading and analysing remote camera data were considered, based on reviewing recent global reviews (e.g. Hartill et al., 2019) and location-specific remote camera studies. Two sampling methods were selected for pilot testing on initial camera data collected at Buller Island. This site was chosen for the comparison because it contains the highest number of animals of the 3 study sites, and best image quality.

4.1.1 Protocol 1: Video read

The video read protocol, which recorded transits across the site boundaries, was examined first. This protocol produced a continuous count for each of the demographic classes of ASL within the site boundaries for daylight readable hours. Due to the high number of individual ASLs within the boundaries there were a very large number of transits across the boundaries. This resulted in 12,829 individual movement records being generated over a 14-day period. Processing at this level of detail took approximately 7.5 hours to read a single day of footage. As it was not possible to consistently identify individual animals, it is unknown how many different ASLs were observed from the footage as the same individuals may have been observed on multiple occasions entering and leaving the FoV.

Preliminary data visualisations have been developed from this data to assist other researchers in ascertaining the type and density of the data that can be obtained using this read technique (Figure 25). Results from a single day (15/8/2018) are displayed, noting that the diurnal activity patterns may not be representative of those from all days at this location. Collectively, 1,539 transits in and out of the FoV at Buller Island were reported on this single day. Note that the boundary designations can be interpreted from Figure 15 and for the purposes of Figure 25, transits across the inland boundary are the sum of the “inland” and “ledge” boundaries shown in the photograph. The results for this single day revealed that ASL movements within the FoV occurred throughout the daylight readable hours, with animals moving in both seaward and landward direction. Panels A and B in Figure 25 take each movement (positive or negative) into account while panel C displays the cumulative count for each class in every 5-minute interval. In this latter instance, a positive and a negative movement between beach and ocean by the same class animal within a 5 minute-period would cancel each other out.

Footage collected as part of this study is available to interested parties, which would enable the video read to be used to obtain detailed information for other days of interest to researchers. Using this method, it would be possible to examine trends at the scale of minutes in:

- beach occupancy by demographic group,
- patterns of activity and mobility either overall or broken down by demographic class, and

- correlative trends such as positive or negative association between cow, bull and pup occupancy.

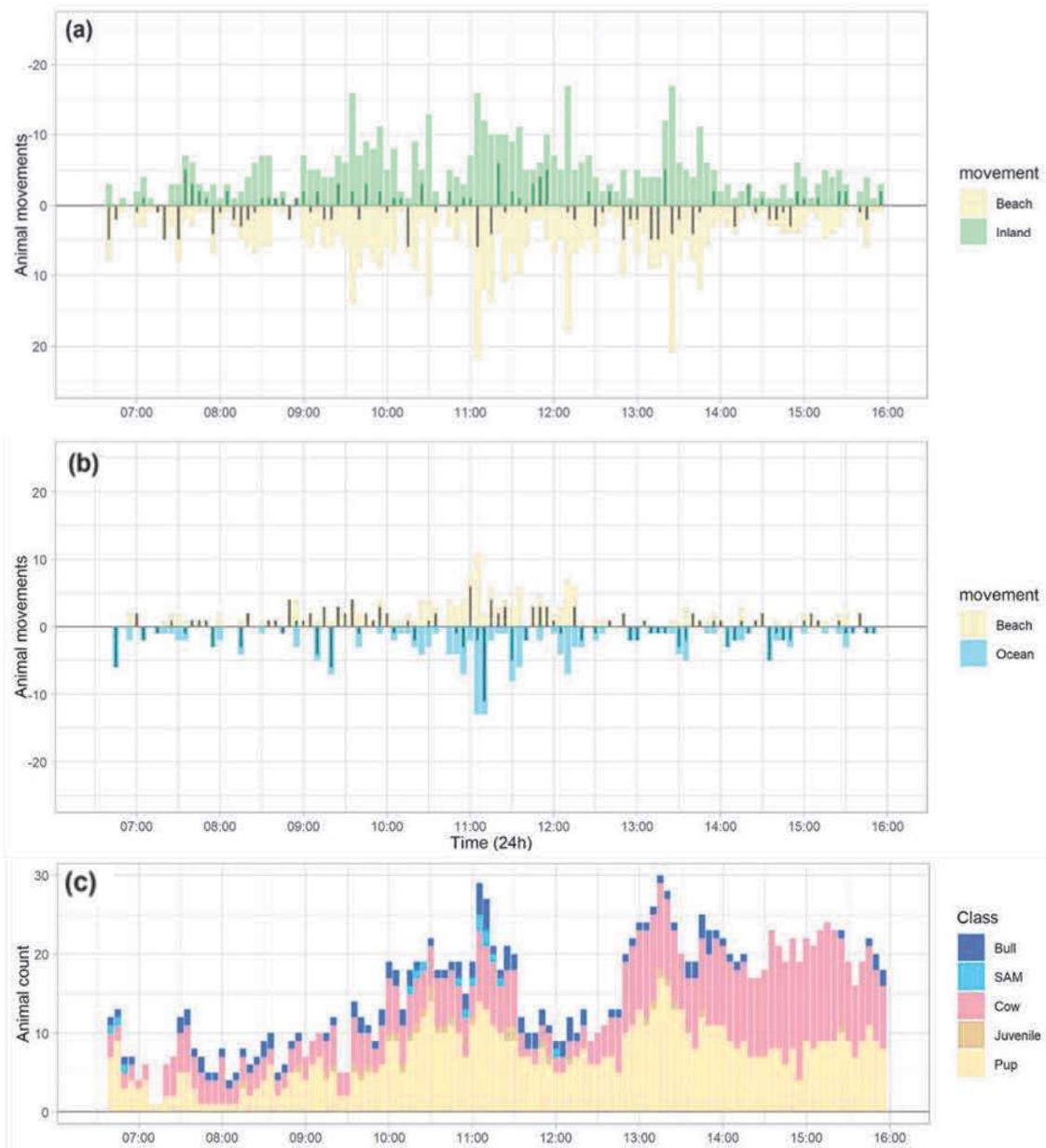

Figure 25. Representation of the "video read" data from one single day (15/08/2018) at Buller Island, aggregated into 5-minute time intervals: a) number of transits across the beach/inland FoV boundary; b) number of transits across the beach/ocean FoV boundary; c) stacked histogram showing the total number and class composition of the animals within the FoV. For panels a and b, positive values indicate animals moving into the FoV while negative values indicate animals leaving the FoV, and narrow black bars indicate net movement during that time interval.

4.1.2 Protocol 2: Still read

The still read protocol, which counted the numbers of ASLs in each of the demographic classes at 15-minute intervals throughout the day, was trialled on the same footage from Buller Island (i.e., 14-day period, daylight readable hours). Processing at this level of detail took approximately 2 hours to read a day of footage which was more than three times quicker than the video read approach. Therefore, the still read approach was considered to represent a more efficient and cost-effective way of processing the large number of video files collected during the project.

Within a given day, the number of animals within the FoV can vary substantially as indicated in Figure 26. For example, at Buller Island, variability in the number of pups (0–35) and cows (0–35) visible from the footage at any one time, on a given day, was substantial (Figure 26). As subsequent analysis was based on the daily MaxN value, in the interests of trying to improve the cost-efficiency in manually reading the data, the time of day when the MaxN value occurred was investigated (Figure 27). At Buller Island, the location where the highest ASL counts were recorded, the daily peak in counts of pups and cows was consistently recorded between 13:00 and 17:00.

4.1.3 Preferred reading approach

Based on the pilot testing, the best method of manually reading the remote camera data was determined to involve:

- the still read method for all three locations;
- restricting the still read method to period between 13:00 and 17:00 at Buller Island, capturing MaxN for the day.

This was applied to all camera data collected as part of the study, and specifically for addressing Objective 2.

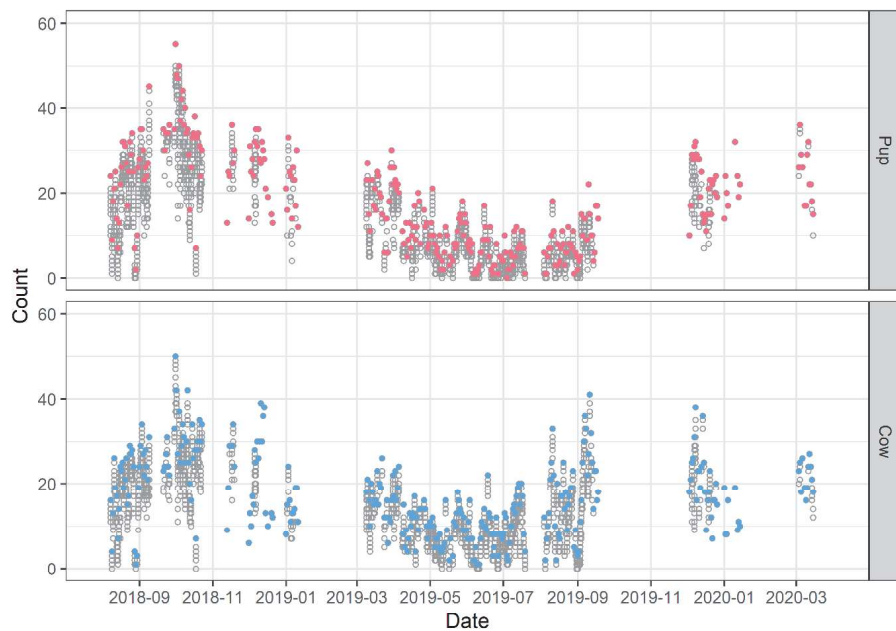

Figure 26. Representation of the "still read" data from the full time series of readable days over the study period at Buller Island. Coloured, filled circles represent the greatest number of each demographic class on each day (MaxN). Open circles

represent counts of each demographic class at 15-minute intervals that were less than the MaxN.

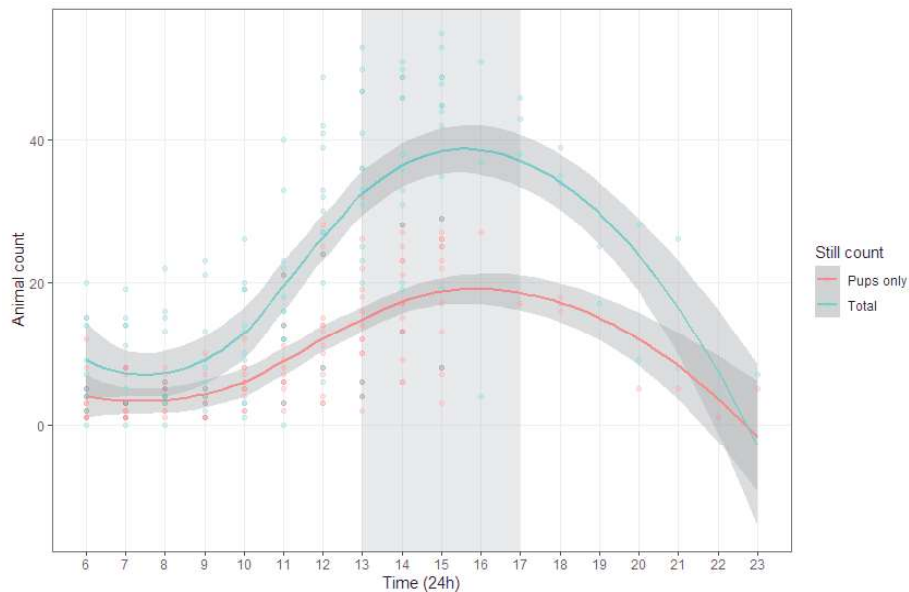

Figure 27. Counts of the demographic classes of ASL at Buller Island in each 15-minute interval recorded over a 14-day period using the still read protocol. Fitted line visualises the window of time in which the MaxN consistently occurred. Grey shaded box (13:00-17:00) refers to the ‘restricted’ period used for subsequent analysis.

4.2 Objective 1: Evaluate the feasibility of using remote cameras as a method for monitoring the status of Australian sea lion colonies.

Camera performance metrics were developed to evaluate the feasibility of using remote cameras for monitoring ASLs. These metrics are directly relevant to the current study, and other studies where there is a need to monitor ASLs at remote locations.

4.2.1 Provide continuous footage

The first, most fundamental performance metric for testing the feasibility of any remote video monitoring tool is to determine whether the system can collect long-term footage. Camera uptime and data retrieval statistics are useful to assess this performance metric. Overall camera uptime was defined as the percentage of time that the cameras produced footage. This incorporated downtime from any source that impacted on the creation of the final footage such as camera/component malfunction or data retrieval issues. It is a measure of the number of hours of footage that appear in the final data set vs the total number of possible hours between commission and decommission of each camera. i.e., how much footage was successfully recorded and transferred back to the central data storage. Since the cameras were designed to record continuously, this percentage is a measure of the camera systems’ stability and reliability. A full calendar of camera uptime for all three camera systems is presented in Appendix 1.

The Buller Island camera system was the first installed. Data collection began on the 07/08/2018 and ceased on 16/03/2020 (588-day period), which is greater than the 18-

month breeding cycle period of ASLs. Of the total installation period, the system recorded data on 366 of those days. The overall percentage of uptime on this system was 62.2%. Several contiguous data gaps exist in this data set due to various system outages, data failures, as well as decreased image quality due to environmental conditions. This reduced the number of valid counts of ASLs that could be made (Figure 28).

The Wickham Island camera system was installed on the 14/11/2018 and data collection ceased on the 08/10/2019 (329-day period). The system recorded data on 188 of these days, resulting in an overall percentage of uptime on this system of 57.1%. As for Buller Island, there were some component failures on this system resulting in gaps in the data set (Figure 29). Access to this island was severely limited due to weather conditions and the general remoteness of this location. Collectively, this meant it was not feasible to capture data over an 18-month period.

The Haul Off Rock camera system was installed on the 23/09/2018. This site proved to be the least reliable installation with repeated and multiple component failures and technical faults. These issues are outlined in the Discussion within the context of improvements for future camera monitoring. This island is logistically difficult to access under most weather conditions, which limited the opportunities to repair the system. Repeated attempts were made to sustain functionality until 9/11/2019, leading to a total installation period of 413 days. Footage was recorded on 11 days and manually read for 9 days, resulting in an overall percentage of uptime of 2.1%. In addition, still images at 20-minute intervals were also captured for 105 days, or 25.4% of the period. These images were not analysed as part of this report due to concerns about the image resolution and the ability to categorise ASLs (Figure 30).

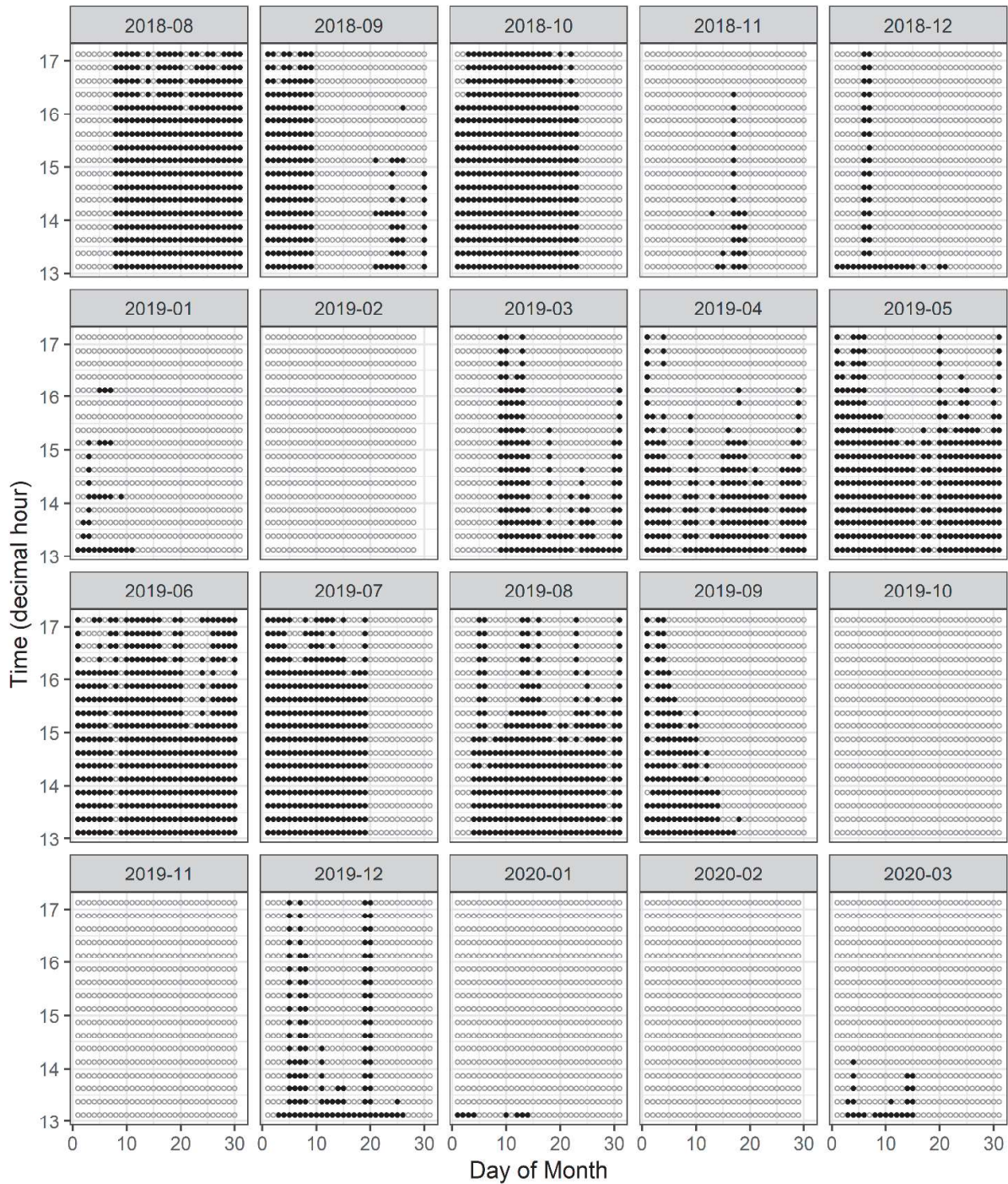

Figure 28. Camera uptime at Buller Island between August 2018 and March 2020 read at 15-minute intervals between 13:00 and 17:00. Observation times with valid counts are depicted by solid circles.

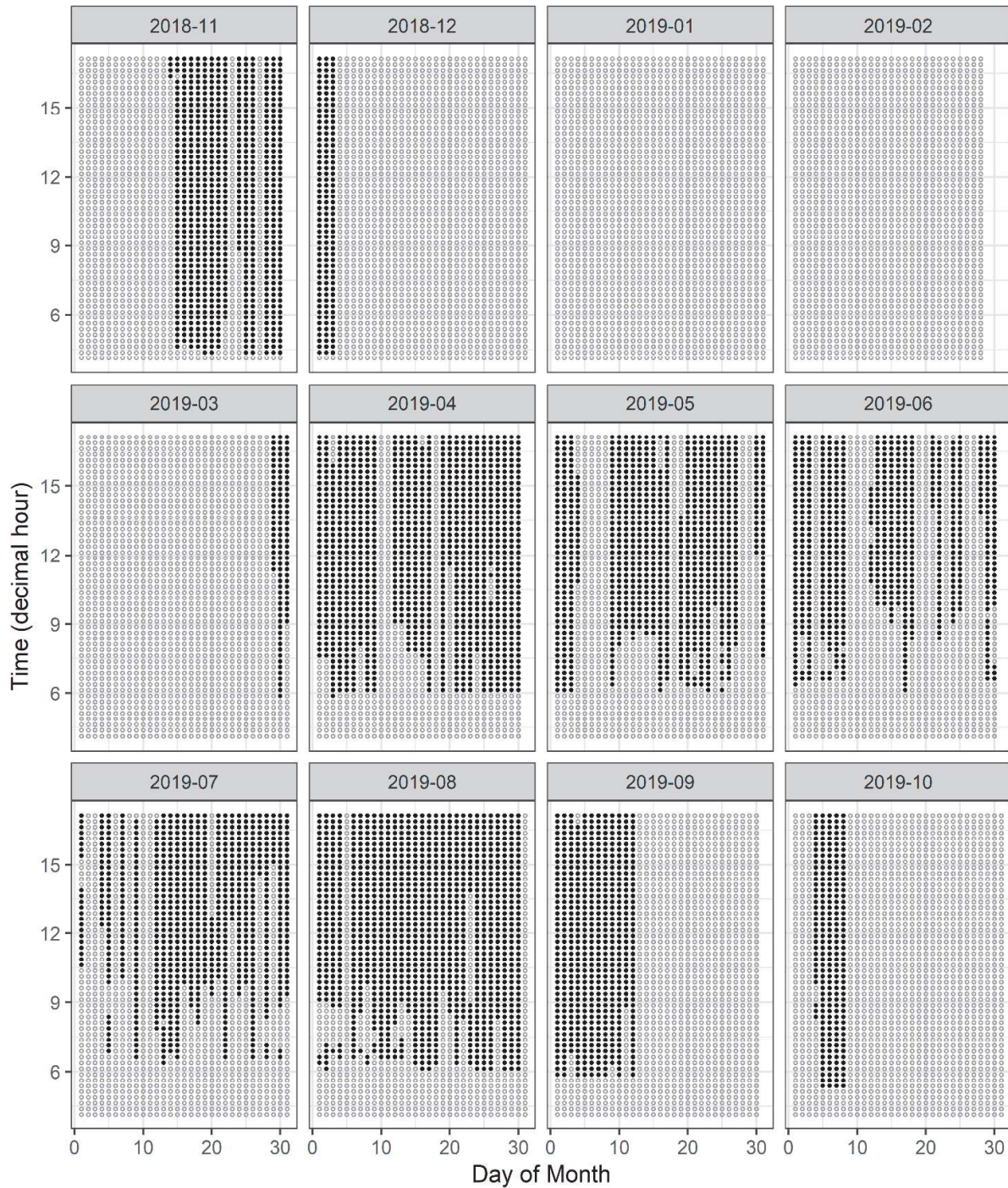

Figure 29. Camera uptime at Wickham Island between November 2018 and October 2019 read at 15-minute intervals between 13:00 and 17:00. Observation times with valid counts are depicted by solid circles.

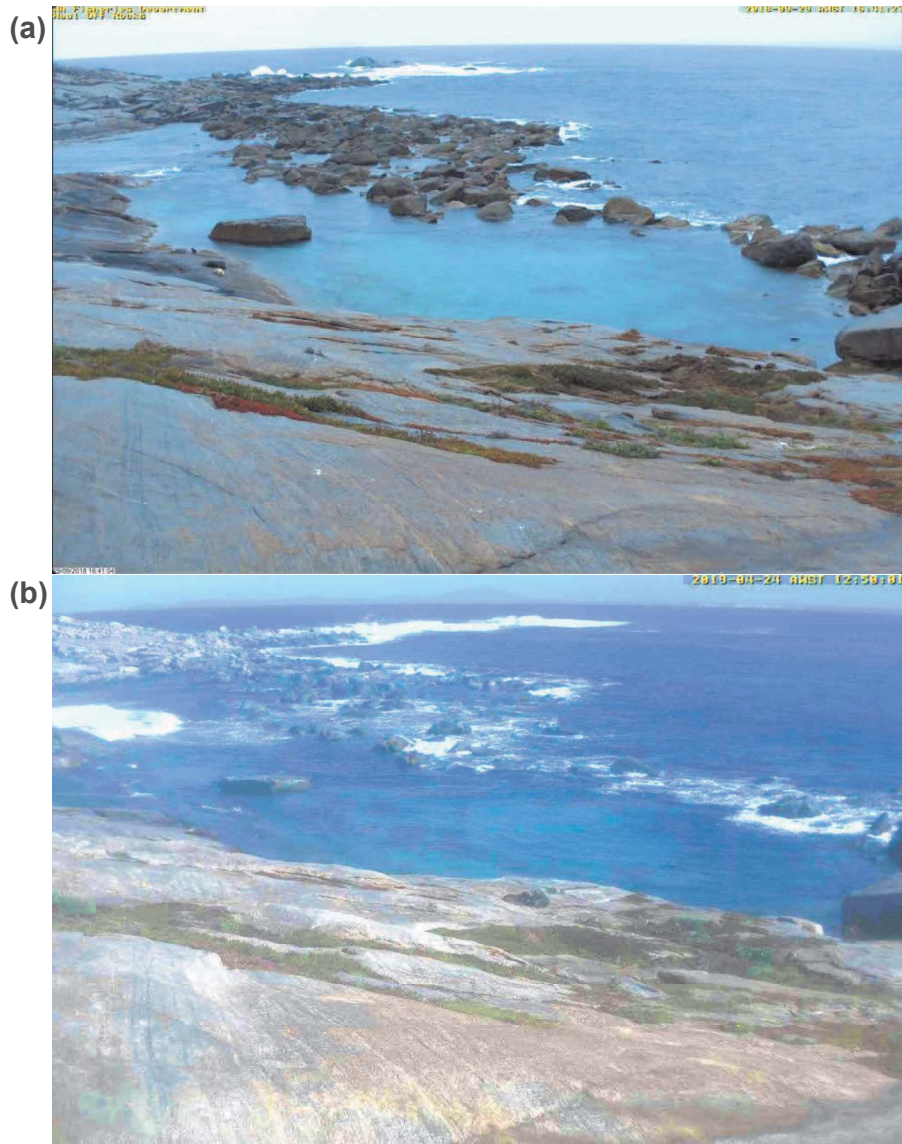

Figure 30. Image resolution comparison at Wickham Island demonstrating images acquired with (a) a fully functioning system and full-size images (3072x2048) and (b) a compromised system remotely reconfigured to acquire images at an increased period and reduced resolution (1536x1024) to reduce the loss of data.

4.2.2 Perform under different environmental conditions

Once the footage was successfully transferred to the central data storage, it was assessed in terms of usability. Initial trials found that the night-time footage was unable to be reliably processed as the footage was still very dark despite using the low light lens. At this stage, the decision was made to focus on processing daytime footage only; however, all night-time footage that was collected has been retained for possible further use. Within the daytime footage data set, the quality of the images varied considerably with respect to three main factors:

- Sun glare: During certain periods of the day sun glare obscured the image, either directly or reflecting off the water. The severity of the glare changed at different times of the year depending on the position of the sunrise. It was also exacerbated by salt buildup on the lenses.
- Salt buildup on lenses: The lenses on the primary (Mobotix) camera were covered with a water and dirt repellent coating which kept the image quality very high most of the time. However, during periods of strong wind with little rain, salt did deposit on the lenses, obscuring the image. The salt buildup was often washed away naturally by rain or was cleaned off during camera maintenance.
- Weather events: On several occasions during the study period the sites experienced extreme weather events. During these periods visibility was often decreased or completely obscured by the rain.

The outcome of these undesirable environmental conditions was the temporary loss of data.

4.2.3 Enable identification of pinnipeds from the camera footage

Once readable footage was identified, the next performance metric was whether pinnipeds could be clearly seen using these systems. Stills from the time lapse footage at all three study locations show clearly identifiable pinnipeds in the field of view (e.g., Figure 19). Against this metric the cameras were successful. Using the video read approach, the time lapse video clearly showed individual animals moving around within the FoV making behavioural and social observations possible.

The variability in the capacity to discern pinnipeds among the different colonies is demonstrated when comparing Buller Island with Wickham Island and Haul Off Rock images. The distance between the camera and the animals at Buller Island (~5–60m from the ledge in front of the camera to the end of the beach) was much shorter than the other sites. The Buller Island topography, with low cliffs by the beach, also provided the best vantage point for the images. These conditions combined mean that animals recorded in Wickham Island and Haul Off Rock images are much harder to discern than those at Buller Island. This is particularly the case against dark-coloured, complex boulder fields like those at Wickham Island compared to the white sand beach of the other sites. In this situation, time-lapse footage examined using the video read approach was easier to interpret than still images since animals could be identified by their movement between frames.

4.2.4 Distinguish ASLs from other pinnipeds from the camera footage

Only one of the islands, Haul Off Rock, was previously recorded as hosting breeding colonies of both ASLs and LNFS. Distinction between ASLs and LNFS in the footage was based on morphological differences (head shape, colouration and body size) as well as on behavioural cues and areas of occupancy. Deducing this information from the footage required prior knowledge of the behavioural characteristics and habitat preference of both species. For instance, LNFS will habitually lie in the water with a single flipper raised in the air while ASLs do not show this behaviour. Likewise, LNFS appear to not venture far from the shoreline at Haul Off Rock, while ASLs will use the interior of the island as well.

Discriminating the two species has partly been confounded by the distance at which animals were viewed at Haul Off Rock. As such, the camera system at Haul Off Rock in the current configuration showed partial capability to be able to discriminate between ASLs and LNFS. Wickham Island was thought to be a single species colony of ASL, without breeding LNFS. Interestingly, during this study, LNFS were shown to use the island in low numbers, and notably, very young LNFS pups were seen at Wickham Island indicating that they were likely pupped at this location.

4.2.5 Identify different population demographics or age classes from the camera footage

In many cases population demographics were able to be determined where the footage was of sufficient clarity. While it was not considered feasible to measure the size of the animals identified in the footage, it was possible to separate individuals into the various demographic classes based on relative size. Pups were tiny, cows mid-sized and bulls were very large. Some ambiguity was evident between intermediate size-classes. For example, older juveniles vs young breeding females were difficult to discriminate, as were some instances of sub-adult males (SAMs) vs bulls. In many situations physical or behavioural cues could be used to place individuals into a demographic class. Smaller breeding females often had a pup feeding or associated with them while large juveniles did not. Breeding bulls were considerably larger than SAMs and usually had the pale head cap visible in the images.

4.2.6 Identify individual animals

In the current configuration, it was possible to follow individual animals between consecutive frames using the video read approach but once the animal left the field of view it could not be reliably identified as the same animal using natural markings or any distinguishing characteristics. It was considered possible that large conspicuous artificial markings such as bleach or dye marks could be visible on the footage; however, applying marks of that kind was beyond the scope of the current project.

4.2.7 Determine whether sub-lethal entanglements or mortalities had occurred

No entanglements or injury attributable to fishery interactions were observed in the footage. Several deceased ASLs were observed from the cameras during the study. Two dead pups were evident in footage from Buller Island (Figure 31), which were verified on the next maintenance visit. Two dead juveniles and one dead pup were found at Wickham

Island during maintenance, all of which were located outside of the camera FoV (Figure 32). None of the mortalities that were able to be inspected in-person showed signs of entanglement. The Wickham Island mortalities were in an advanced state of decomposition and any injuries could not be discerned.



Figure 31. Still frame taken at Buller Island showing two pup mortalities marked with red asterisk.

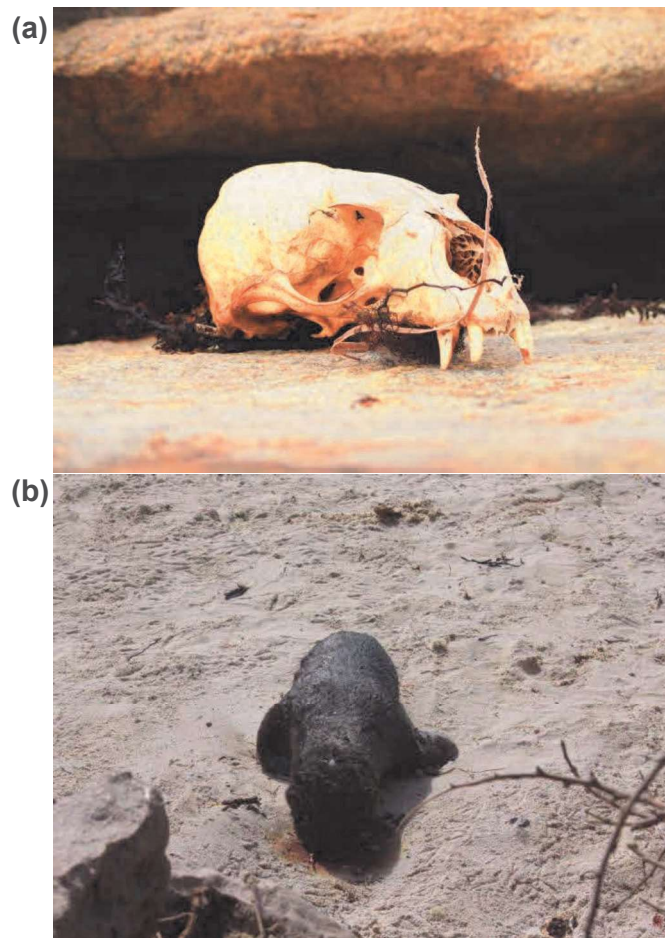

Figure 32. Image of (a) skull of an ASL adult and (b) body of a dead ASL pup taken at Wickham Island.

4.2.8 Record behavioural observations for other animals

The collection and appropriate storage of video imagery enables other ecological or behavioural observations to be made (refer to Objective 3). For example, footage at Wickham Island identified a raptor attacking a young ASL at Wickham Island.

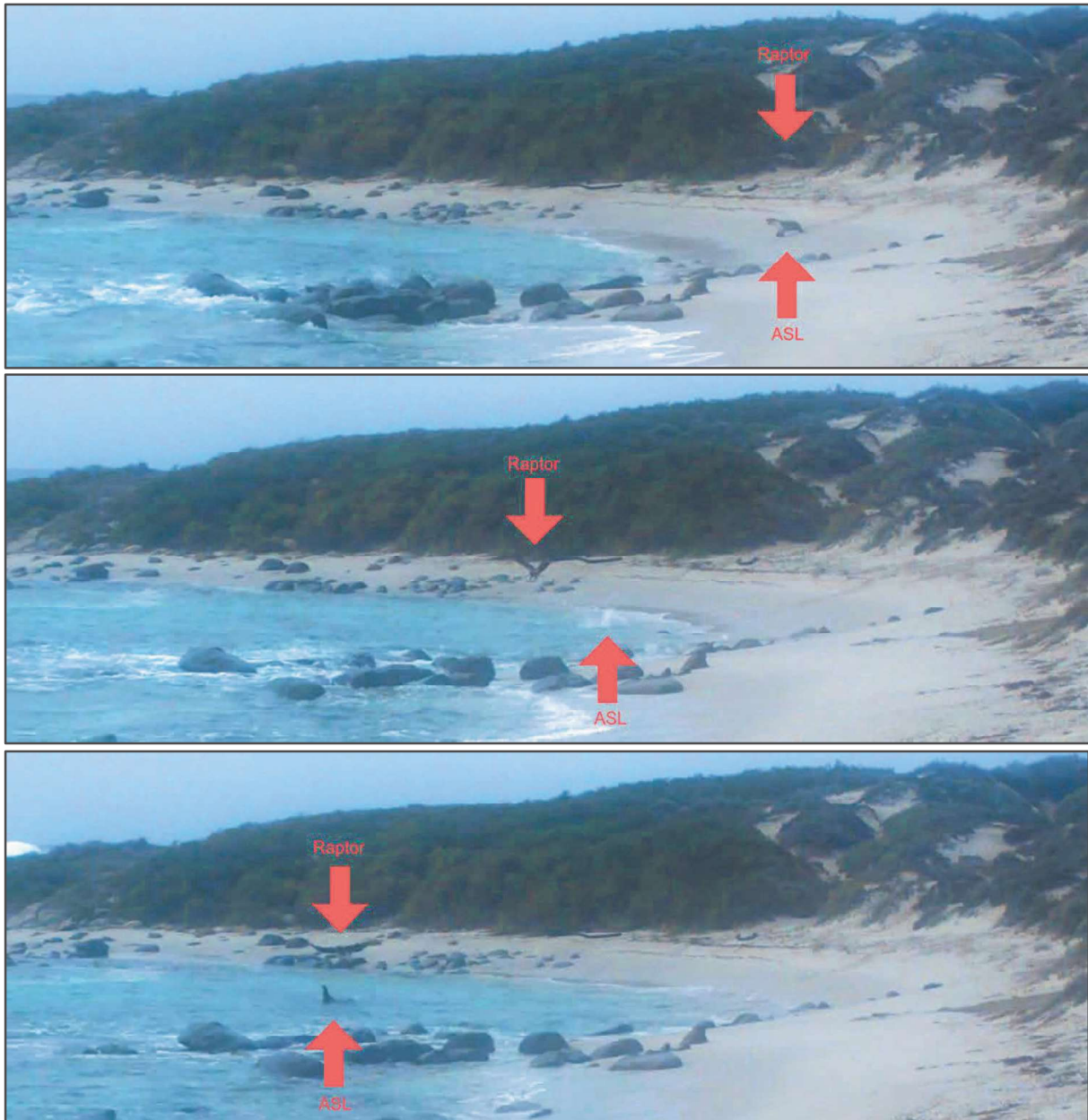

Figure 33. Sequence of three frames showing a raptor attempting to attack a young ASL at Wickham Island.

4.3 Objective 2: Collect sea lion abundance estimates from study colonies over an 18-month period (full breeding cycle) to update understanding of their conservation status.

4.3.1 Variations in MaxN

To address Objective 2, it was necessary to draw on qualitative observations described under Objective 1 above, as well as the quantitative data extracted from the footage using the still read technique. Daily MaxN values by demographic class were plotted to assess monthly variations in abundance.

4.3.1.1 Buller Island

At Buller Island, there were fewer gaps in the data set (Figure 28) enabling the relative abundance of ASLs to be examined in detail across the full breeding cycle (Figure 34, Figure 35). A seasonal pattern was apparent for pups and cows across the 588-day period of data capture. The MaxN for pups peaked at 55 animals on 1/10/2018, consistent with the peak of 50 cows on the same day. A sinusoidal pattern was apparent for pups and cows with lower MaxN values between March and August 2019, followed by a subsequent secondary peak in pups (36 individuals, 4/3/2020) and cows (41 individuals, 11/9/2019). The periodicity of MaxN counts were generally consistent between pups and cows (i.e., 1:1 relationship), although on some days, the number of pups and cows were not comparable (Figure 34).

The highest MaxN value for both SAMS and bulls was less than 10 individuals and there appeared to be little monthly variation in abundance for both demographic classes (Figure 34, Figure 35). The MaxN values for juveniles was also much lower than for pups and cows, with all except one daily MaxN values being less than 10 individuals (Figure 34). Using the still read approach, the review of video footage was restricted to 13:00 to 17:00. Within this four-hour period, there was no obvious pattern in the time at which the maximum daily count was obtained for pups or cows (Figure 36).

4.3.1.2 Wickham Island

The longer distance between the cameras and ASLs, combined with the low vantage point of the camera system, made it more difficult to confidently discern juveniles from pups, and SAMs from bulls. Therefore, these animals were grouped, and all observations classified as: Pup, Cow or Bull.

At Wickham Island, there was a four-month gap in footage between December 2018 and March 2019 caused by system component failures (Figure 37). The data read for the remaining months revealed lower MaxN values than those reported for Buller Island, with pups and cows being identified for all months where data was read. The highest daily MaxN value for pups and cows was 7 individuals while the highest MaxN value for bulls was 3 individuals.

4.3.1.3 Haul Off Rock

Despite the low camera uptime rate and major gaps in the data from Haul Off Rock, footage from this location was read as part of this project. Animal counts were obtained on nine days between 23/09/2019 and 01/10/2019, where the highest MaxN value for pups was 3, the lowest of all locations in this study. These pups did not display a black or brown coat, and were able to swim, indicating they were at least a few months old. Up to 5 dark coat pups were visible in the unprocessed still images for this island on the 27/02/2019

and 24/04/2019 (Figure 30 B), suggesting the parturition period at Haul Off Rock took place earlier that year. The highest MaxN values for other classes were less than 10 individuals (Figure 38; i.e., cow = 8, juvenile = 3, bull = 2, sub-adult male = 2, unknown = 2). The number of LNFS within the FoV at this location was also small, with the highest MaxN value of 2 individuals of any age class. These observations consisted mostly of animals using a low laying access point to the island on the right side of the FoV. As for ASLs, many LNFS were observed (not counted) swimming within the lagoon or basking on rocks in the background.

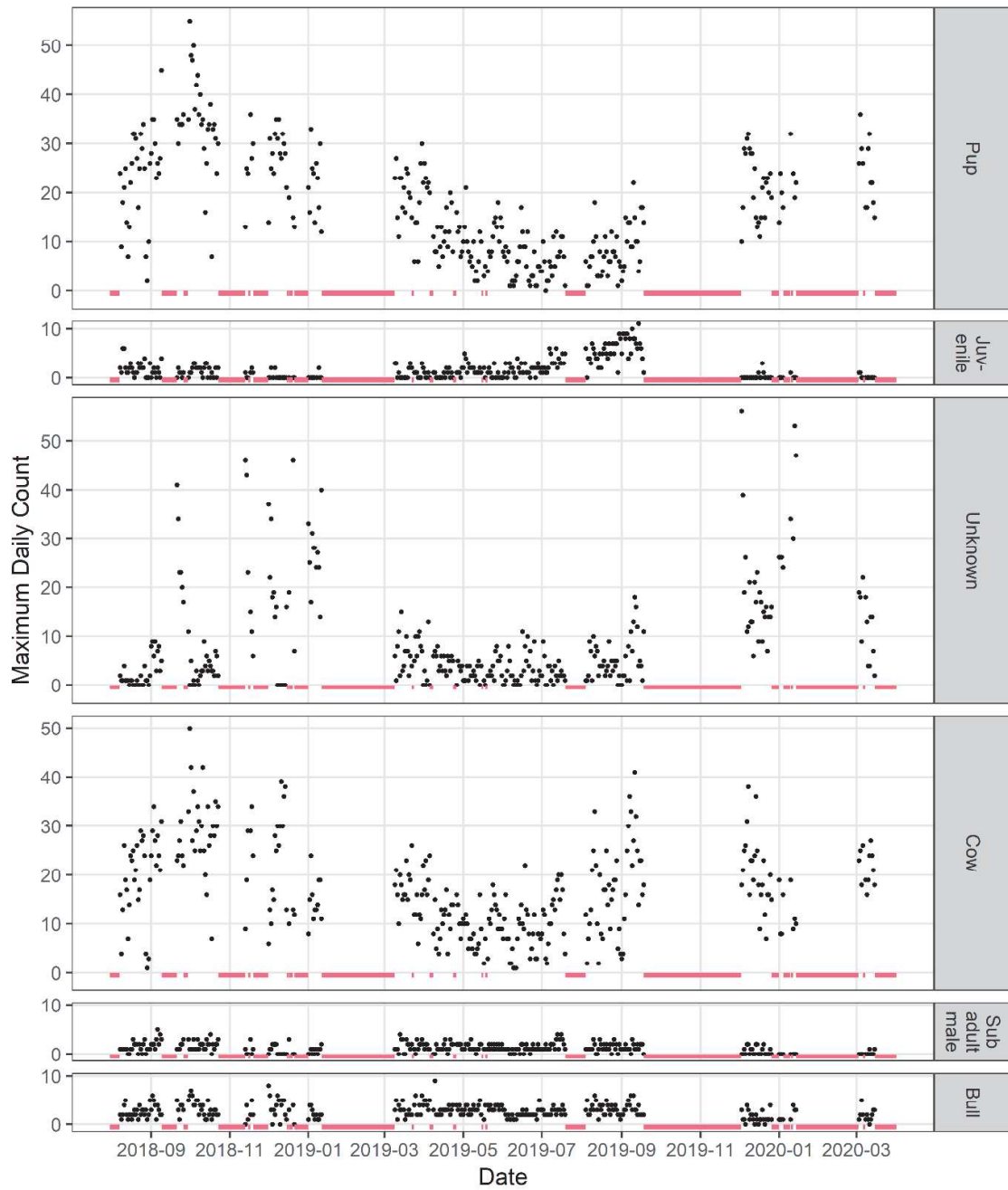

Figure 34. Maximum daily counts for all categories of ASL at Buller Island. Red line represents camera downtime.

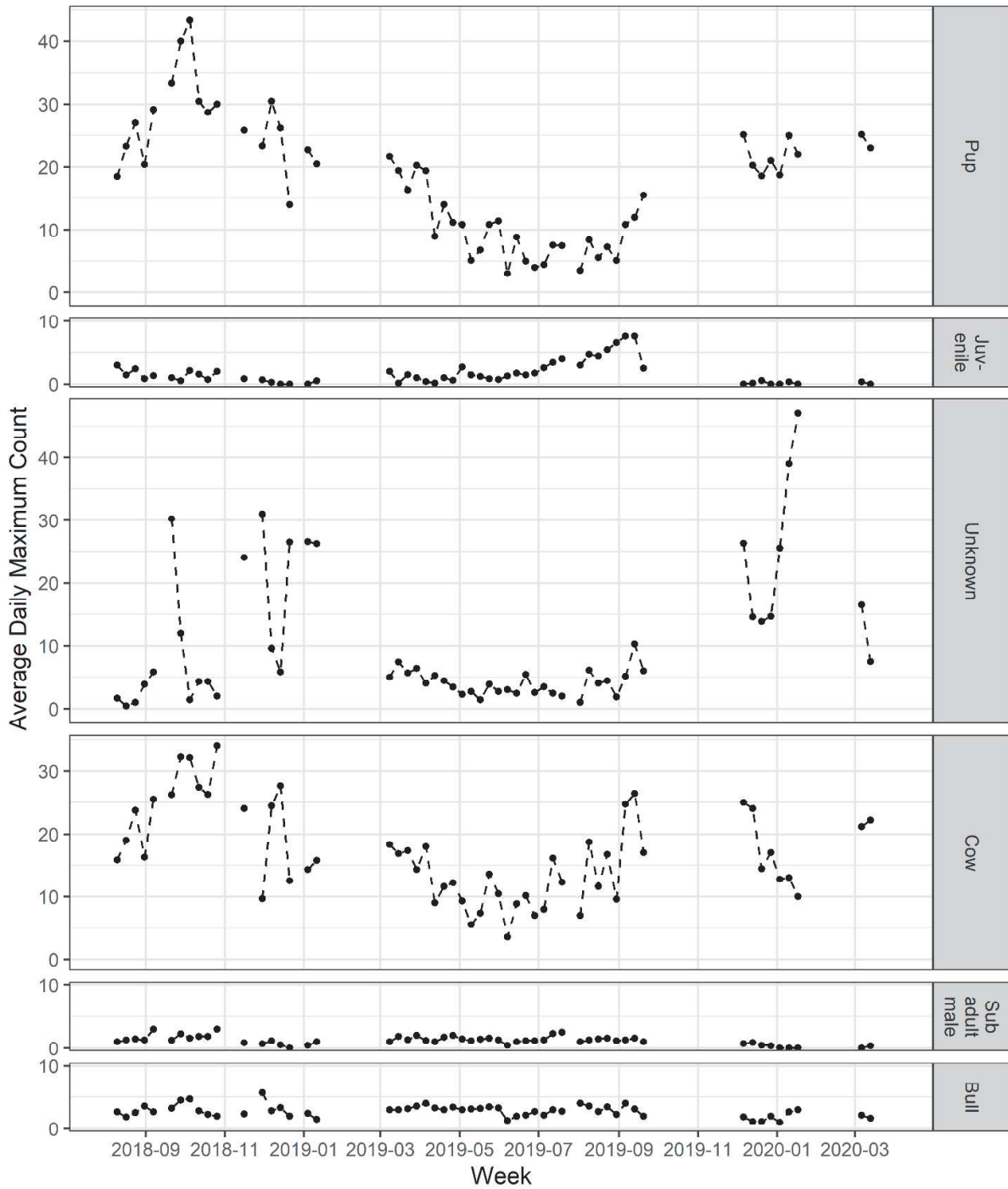

Figure 35. Average daily maximum count by week for all categories of ASL at Buller Island.

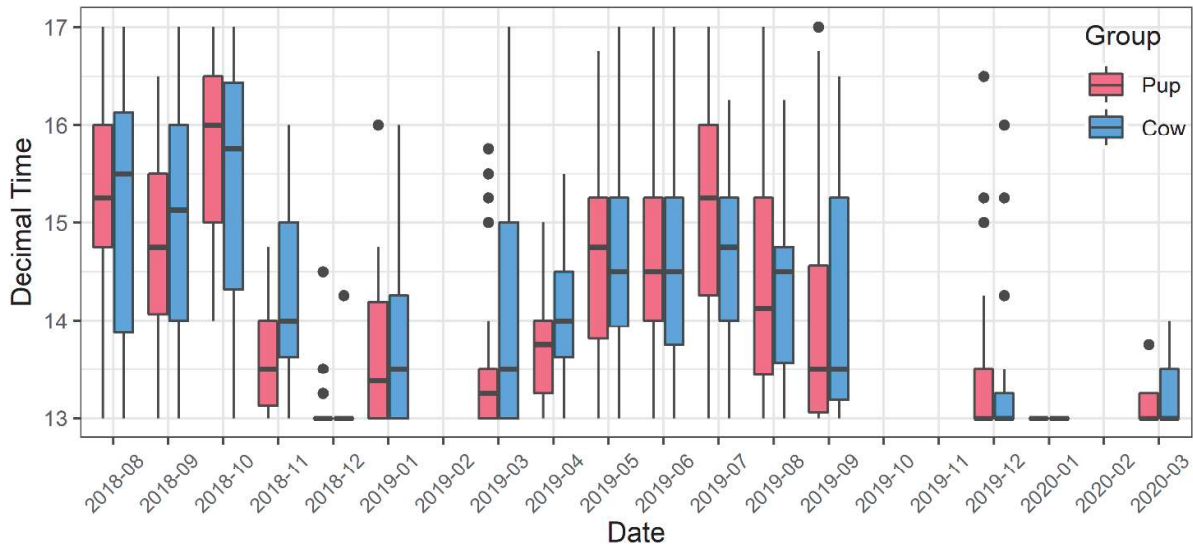

Figure 36. Box and whisker plots showing daily maximum count data at Buller Island grouped by month for pups (red) and cows (blue). Solid horizontal black line within each box represents the median value, lower and upper edges of each box represent the 25th and 75th percentiles Lower and upper extremities of the vertical line for each month indicate the most extreme data point which is no more than 1.5 times the interquartile range, with outliers indicated by solid circles.

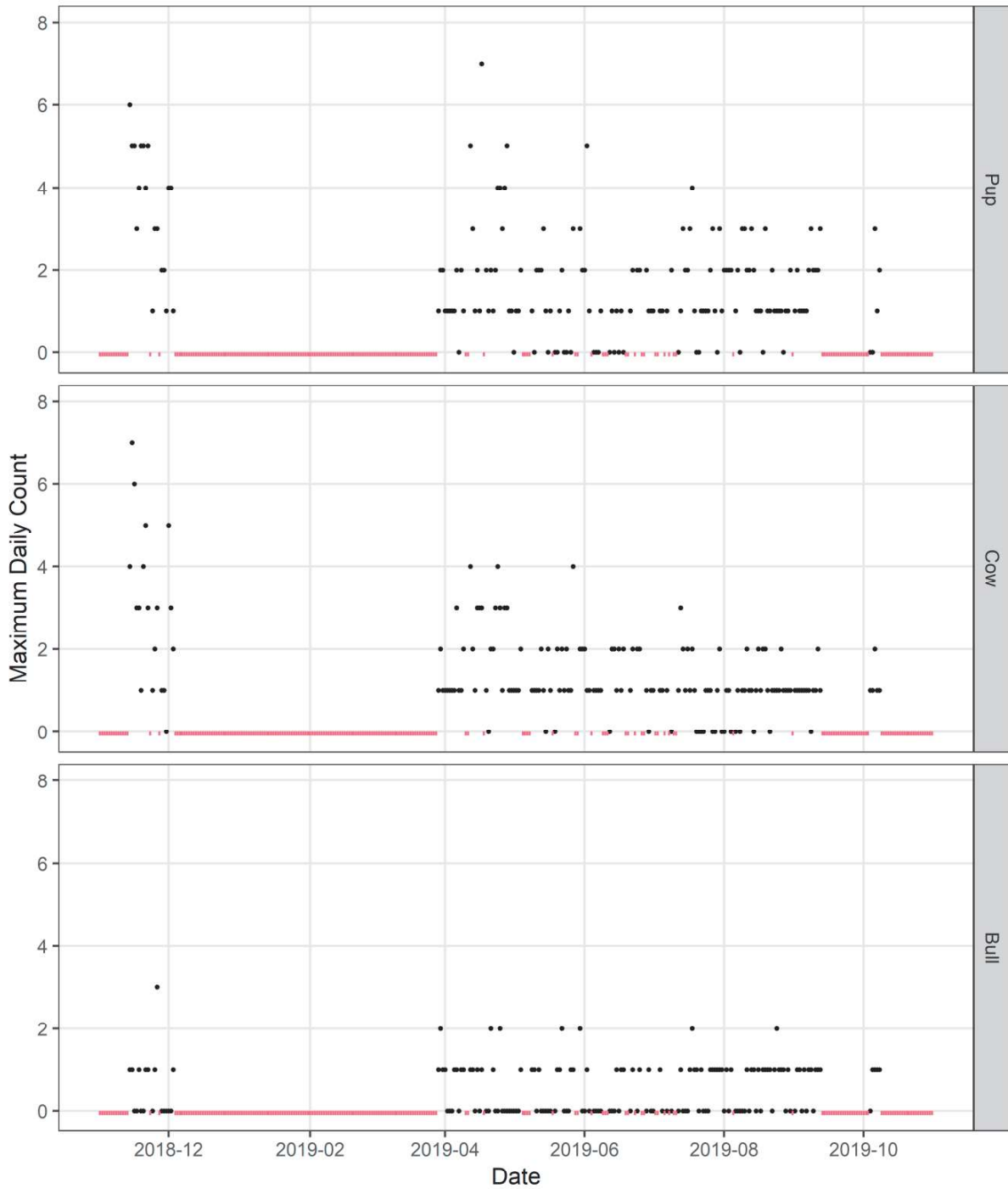

Figure 37. Maximum daily counts for each category of ASL at Wickham Island. Red line represents camera downtime.

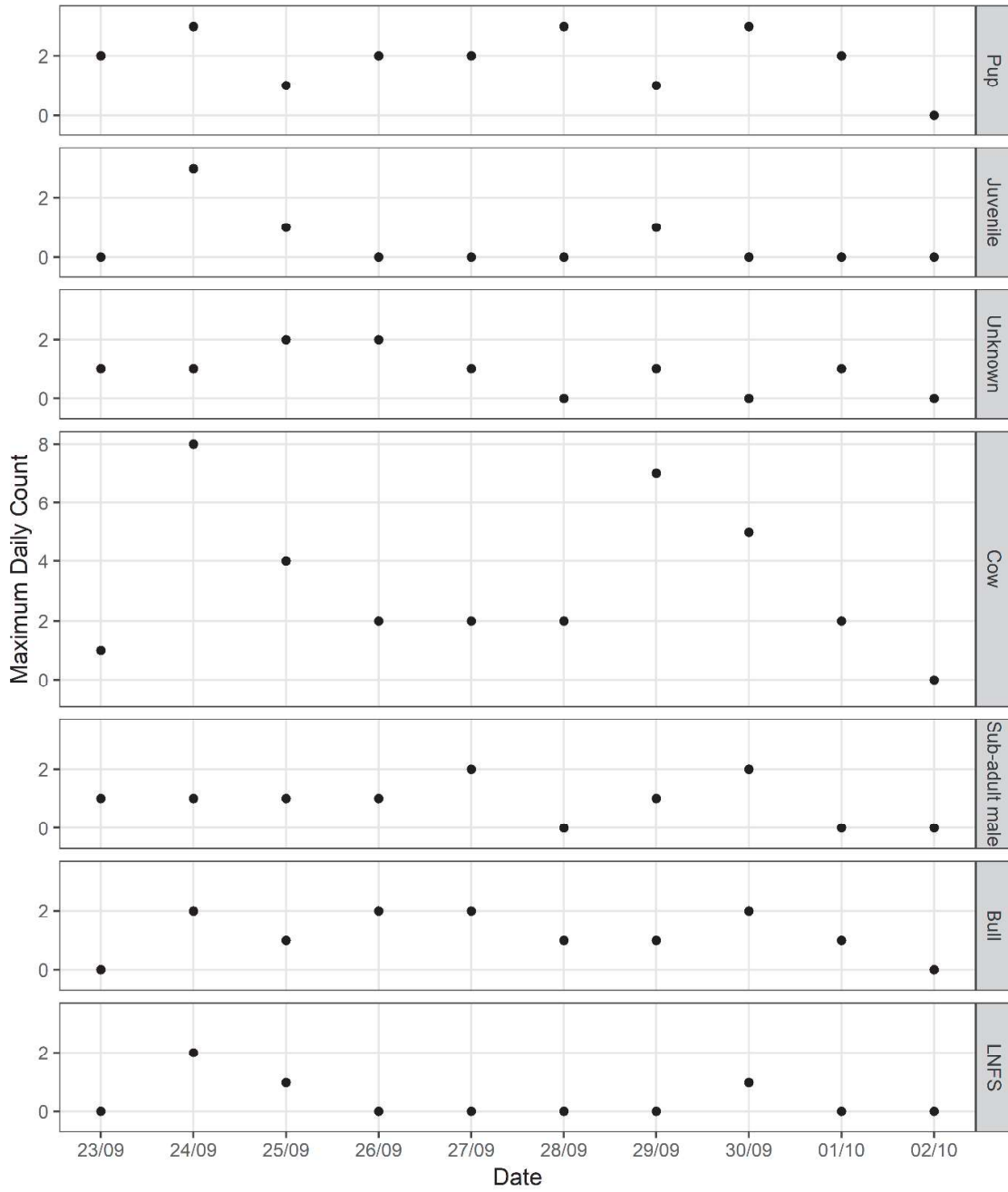

Figure 38. Maximum daily counts for each category of ASL at Haul Off Rock.

4.3.2 Time series analysis for Buller Island data

Sinusoidal models were applied to the MaxN values for pups and cows displayed in Figure 34. Time series analysis was restricted to Buller Island due to the gaps in camera footage encountered at the other two locations. For both pups and cows, the AIC value for the Negative Binomial model was substantially lower than for the Poisson model and the former was considered to be the more parsimonious model. Those estimates and derived variables from the Negative Binomial model are thus considered to be the most appropriate (Table 2, Figure 39).

The mean MaxN values for pups and cows were very similar, with a mean MaxN of 17.79 (95% CI 16.87 – 18.70) for pups and 17.1 (95%CI 16.13 – 18.07) for cows. Modelled peaks in MaxN values for pups occurred on 6/11/2018 and 18/3/2020 (Table 2, Figure 39). Corresponding peaks in MaxN values for cows occurred on 7/11/2018 (i.e., one day after the pup peak) and 16/12/2019 (Table 2, Figure 39). The estimated model phase for pups was 471 days (~1.3 years), and 401 days for cows (~1.1 years). The prediction range for the sinusoidal model peaked at 55 pups (Figure 39) and 51 cows (Figure 39).

Table 2. Estimates, standard errors and 95% confidence intervals of derived variables for the Buller Island timer series data. C = mean, A = amplitude, ω = period, φ = phase, θ = dispersion parameter, AIC = Akaike's Information Criterion

Model	Parameter	Poisson		Negative Binomial		
		Estimate	95% CI	Estimate (SE)	95% CI	
Pups	C	17.76	[17.28, 18.25]	17.79 (0.47)	16.87, 18.70	
	A	11.69	[11.09, 12.30]	11.87 (0.56)	10.77, 12.97	
	ω	509.57	[489.96, 529.18]	498.22 (17.21)	464.49, 531.95	
	φ	475.56	[467.03, 484.10]	471.23 (6.91)	457.69, 484.78	
	θ	NA	NA	8.68 (1.20)	6.33, 11.03	
	Peak	2/11/2018	24/10/18-11/11/18		6/11/2018	22/10/18-21/11/21
		25/03/2020	13/03/20-07/04/20		18/03/2020	26/02/20-09/04/20
	nLL	1132.61		1024.46		
AIC	2273.21		2058.92			
Cows	C	16.96	16.49, 17.42	17.1	16.13, 18.07	
	A	7.34	6.69, 7.98	7.74	6.39, 9.09	
	ω	409.61	392.21, 427.01	404.29	373.07, 435.52	
	φ	399.49	391.33, 407.64	401.36	387.91, 414.81	
	θ	NA	NA	6.12 (0.71)	4.73, 7.51	
	Peak	1/11/2018	22/10/18-10/11/18		7/11/2018	20/10/18-24/11/18
		15/12/2019	04/12/19-27/12/19		16/12/2019	26/11/18-04/01/20
	nLL	1256.26		1068.87		
AIC	2520.53		2147.75			

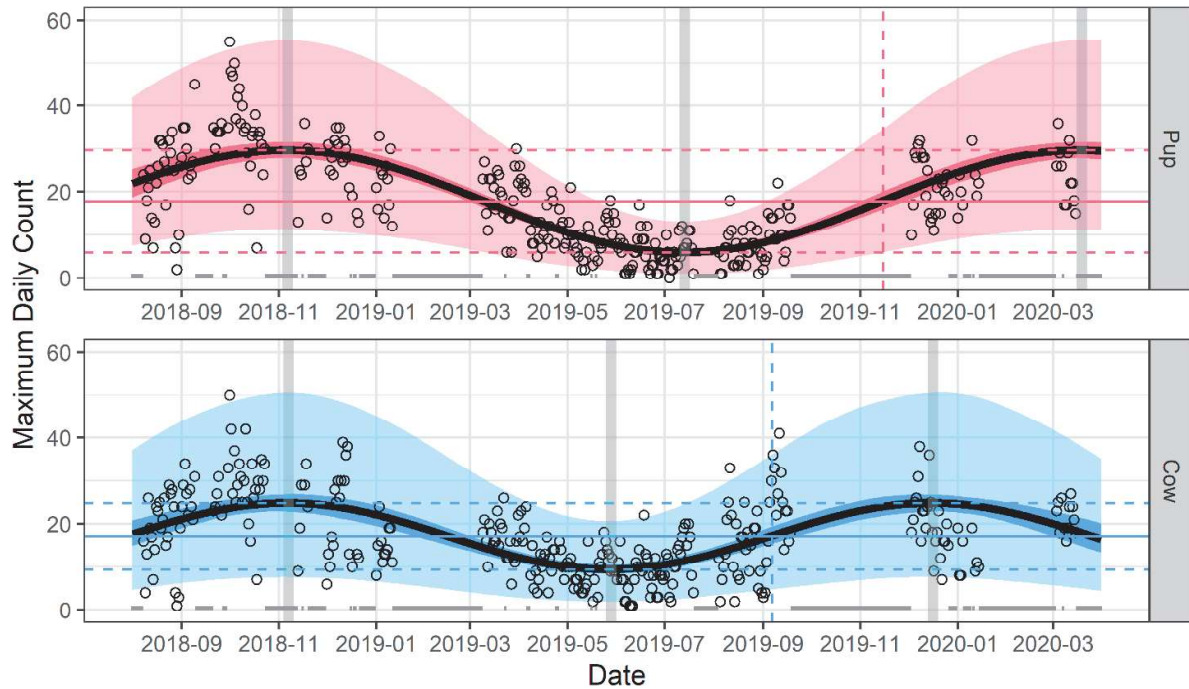

Figure 39. Sinusoidal models fitted to maximum daily count of pups and cows at Buller Island assuming a negative binomial error distribution. Dark shaded regions indicate estimated 95% confidence regions, and light shaded regions indicate 95% prediction regions. Shaded grey vertical lines indicate peaks and troughs in estimated counts. Horizontal pink and blue lines indicate mean pup and cow count levels, respectively, with associated dotted pink and blue lines indicating the lower and upper 95% confidence limits.

4.3.3 Comparison between camera and BoG data sets

Although the camera and BoG data sets are not directly comparable (refer to Methods) attempts were made to compare all available counts of ASLs obtained from the different methods at Buller Island. These comparisons were made within a single reproductive cycle and across multiple reproductive cycles (historical BoG counts vs camera data).

The first comparison related to the identification of the first newborn pup in the camera footage vs pups counted during the BoG survey. The date at which the first black pups ($n=2$) were visible in the camera footage was 20/3/2019. The BoG field trips for black pups in that survey period were on: 14/02/19 ($n=0$), 27/03/19 ($n=5$), 01/05/19 ($n=13$). This confirms that a black pup was first visible in the camera footage 7 days before being identified during the BoG approach.

The MaxN values obtained for pups from the camera and BoG data peaked at a similar level of magnitude (Figure 40). However, the rising trend in values obtained for pups from the BoG data during July 2019 was not consistent with camera data for the same period (Figure 40). To some extent, this reflects the ecology of ASLs on Buller Island. Newborn pups are not very mobile and tend to stay within the vegetated, inland part of the island which can be visited and searched during BoG surveys. As the pups become more mobile and start to venture out to the beach and ocean, they become noticeable to the cameras. In addition, the rising trend in values reported in the 'unknown' category from the camera

data between July and December 2019 is consistent with the concurrent trends reported in BoG counts (Figure 40).

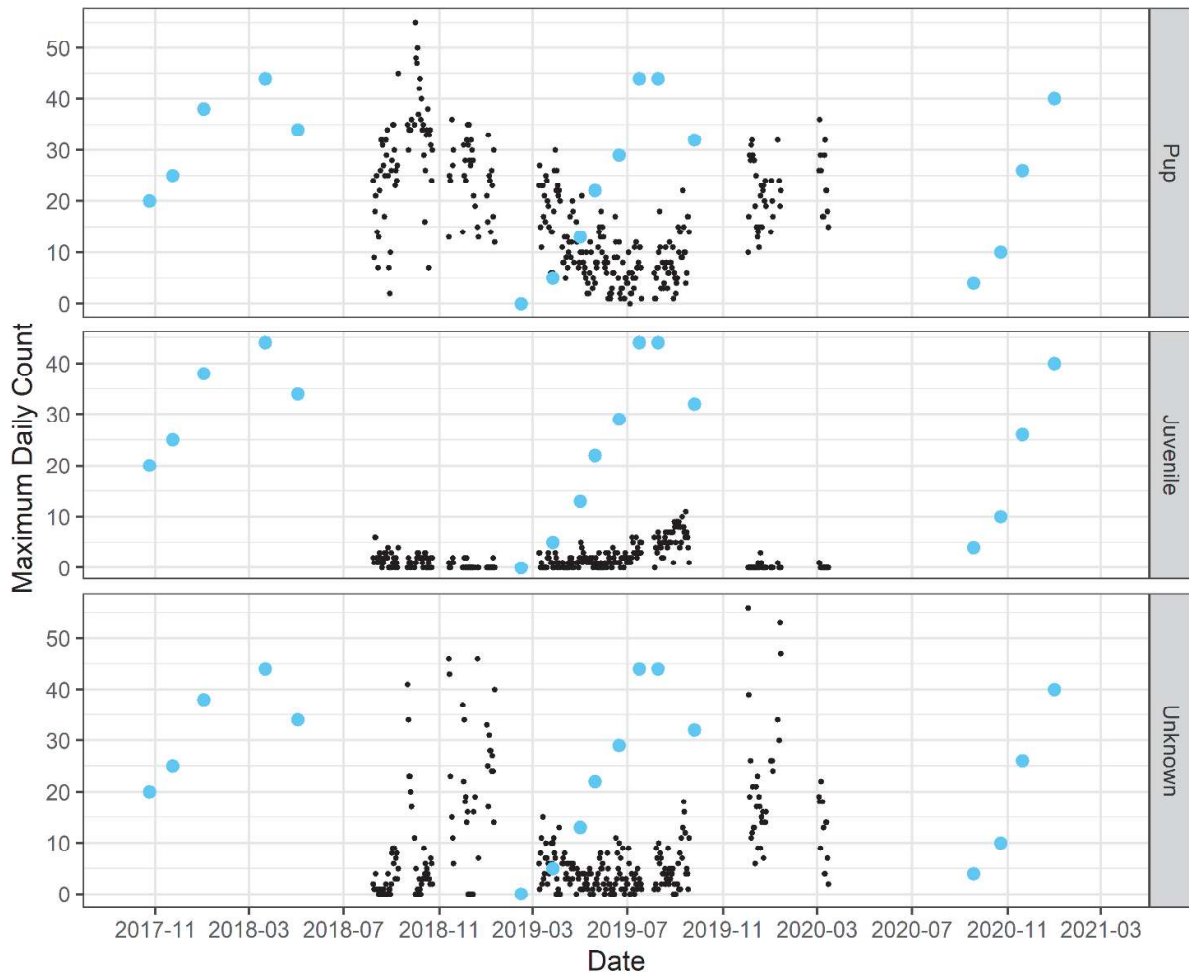

Figure 40. Comparison between pup counts obtained from the camera data (MaxN, indicated by black circles) and from boots on the ground surveys (BoG, indicated by blue circles) at Buller Island while the camera was operational. Differences in data comparability are discussed in the Methods section.

Inter cycle comparisons drew on historical time series of maximum pup abundance at Buller Island published in Goldsworthy et al. (2021) between 1989 and 2019, generated using traditional BoG counts. Analysis of that time series data revealed an overall change in pup abundance over 3 generations as a 6.1% increase, in contrast to most of the 30 breeding sites in SA and WA examined that exhibited negative population growth (reported in Goldsworthy *et al.*, 2021). The time series analysis from this camera study, and in the particular the upper prediction limit from the sinusoidal model, is broadly consistent with the historical trend in BoG counts, notwithstanding differences in these two types of survey (Figure 41).

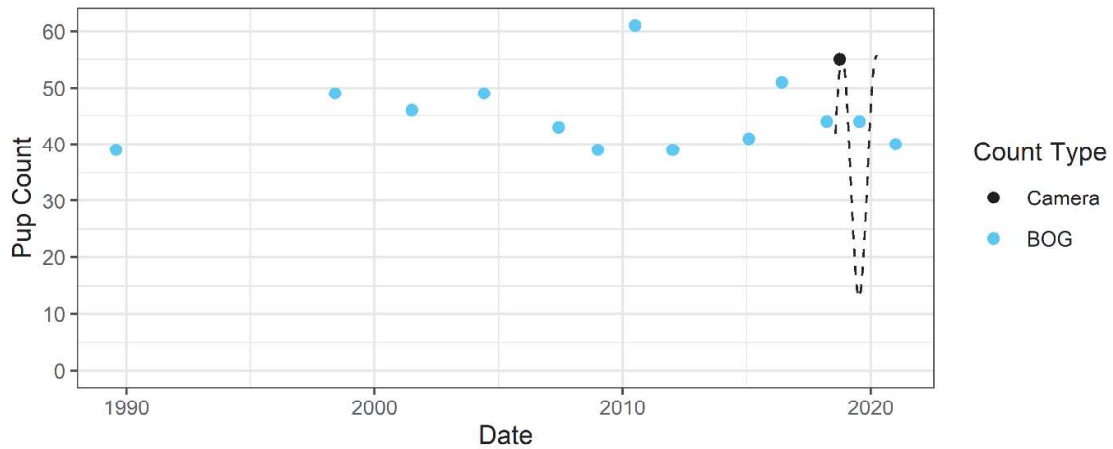

Figure 41. Comparison of pup counts between the camera time series analysis and from boots on the ground surveys (BoG) at Buller Island. Values for BoG surveys were provided by the DBCA and also reported in Goldsworthy et al., 2021 (Supplementary Material). Dotted line for the camera data represents the fitted sinusoidal model, solid black circle represents the upper prediction limit (refer to Figure 35). Differences in data comparability are discussed in the Methods section.

4.4 Objective 3: Provide continuous time-series vision and ancillary in-situ data for other ecological or behavioural research in dynamics of WA sea lion colonies.

All time-series vision collected as part of this project is available for subsequent viewing. Therefore, this objective has been met to the largest extent possible.

Examination of this footage revealed many incidental observations for ASLs that were outside the scope of the current study. This includes cow/pup associations, mating and breeding behaviours, and attempted predation by a raptor towards a pup. While the footage has not been processed to read these data, it is available for further studies to extract the information as required.

In addition to ASLs, other animals were often present in the footage. This included seabirds such as gulls (*Laridae*), terns (*Sternidae*) and cormorants (*Phalacrocoracidae*); and raptors such as white bellied sea eagles (*Haliaeetus leucogaster*) and ospreys (*Pandion cristatus*). A resident flock of the vulnerable listed subspecies of Cape Barren Geese (CBG; *Cereopsis novaehollandiae grisea*) was often present in the footage from Wickham Island, and adults with chicks were commonly seen on the beach.

One of the most significant advantages of installing fixed video cameras was the ability to record continuous images without interfering with the natural behaviour of the animals. Within the footage collected there was the capacity to collect behavioural information at both fine and coarse temporal scales. This included daily patterns of beach usage as well as demographic changes over the period of the breeding cycle.

A calendar showing the periods of uptime and downtime for each of the three camera systems is included in the Appendices. This metadata is intended to serve as a guide for future users of the data to determine the applicability of the footage to their need.

5.0 Discussion

Monitoring and assessing populations of ASLs in WA has been hampered by the remoteness of many of the colonies. This has contributed towards a lack of time series data which remains an impediment for an accurate understanding of population size and trends. In response to this, this study developed and tested a novel method for monitoring ASLs at three colonies using remote cameras. The rationale for this study is clearly linked to the ASL Recovery Plan, within which the need to investigate innovative methods of estimating ASL population size and trend is clearly articulated.

It is hoped that this report, and the technical considerations related to camera monitoring and analysis of imagery, will be of assistance to other researchers in their respective studies. From a WA context, the data generated from this study provided the most comprehensive account of a single ASL breeding cycle at Buller Island. To 'value-add' from the original aims of the study, RPA operations were also conducted within the Recherche Archipelago to provide a greater understanding of the potential application of both methods in on-going monitoring (see below).

As with most trials involving innovative methods, aspects of this project went well while challenges were also encountered, particularly for the remote camera location at Haul Off Rock on the South Coast. The rather ambitious objective of providing near-real time footage and relative 18-month abundance estimates for all study locations was not met. Detailed information on the relative abundance of ASLs was obtained for Buller Island, enabling time series analysis to provide an in-depth account of monthly fluctuations in pup and cow abundance within a reproductive cycle. Gaps in camera footage at Wickham Island precluded time series analysis from being applied for this colony, although readings of the footage provided estimates of maximum abundance for ASL cows and pups at this site. The logistical and technical issues of maintaining continuous footage at Haul Off Rock, the most remote site examined as part of this study, restricted the use of the camera footage collected at this location. However, estimates of maximum abundance for ASL cows and pups were recorded for this site.

This study demonstrates that remote camera monitoring does not provide a remedy for all the issues identified in the ASL Recovery Plan in relation to assessing population sizes and trends. However, as outlined below, there are applications for the type of data that can be obtained from remote camera monitoring and those issues encountered in this trial are not considered to be unsurmountable to remedy.

The applications and limitations of the camera monitoring approach are discussed below.

5.1 Objective 1. Evaluate the feasibility of using remote cameras as a method for monitoring the status of Australian sea lion colonies.

All methods of monitoring wildlife populations have their strengths and limitations. For more traditional methods, such as the BoG counts that have been routinely applied to monitor ASLs, there is a better understanding of how these methods can be applied and their limitations. For emerging techniques as applied in this study, it is less understood whether the perceived benefits eventuate in the field. Pilot studies such as this project provide useful 'hands on' information for evaluating the strengths and limitations of these newer approaches.

The camera performance metrics examined as part of this study inform the use of cameras to monitor the status of ASLs. While cameras are theoretically able to provide '365 days a year 24-7' coverage within the FoV, within this study, the cameras and associated infrastructure were not fully operational for the 18-month study period. The overall percentage of camera uptime at Buller Island, Wickham Island and Haul Off Rock was 62%, 57% and 2%, respectively. Those percentages for Buller Island and Wickham Island are consistent with values obtained from other camera studies that have been applied to fisheries research (e.g. Afrifa-Yamoah *et al.*, 2019; Hartill *et al.*, 2019). How-to-guides have been developed to assist in camera monitoring in both fisheries and wildlife research (Lynch *et al.*, 2015; Hartill *et al.*, 2019; Course *et al.*, 2020) and the importance of maintaining and servicing equipment is often cited as a key part of minimising outages and preserving the ultimate use of the data. For remote, offshore locations, prevailing sea conditions and safe access to the colony also needs to be considered in the scheduling of maintenance trips. For very remote offshore locations, such as Haul Out Rock, it can be logistically impractical to conduct these maintenance trips when weather conditions prevent the safe access to these locations for large parts of the year.

Another key consideration in examining the feasibility of using remote cameras is how the FoV provided by a camera relates to the areas used by ASLs at colonies. When the ASL population is concentrated in a small area or where there is limited access to the sea through a single 'choke point', the counts obtained from the camera data are likely to be more representative of the abundance of these animals at the location. This was the case at Buller Island where one relatively small beach provided the only access on and off the colony, enabling a single camera to provide coverage of all animals. However, even if the camera can be positioned to provide footage for the entire area occupied by ASLs, consideration also needs to be given to sightability (also referred to as visibility bias) issues that can arise (Pollock *et al.*, 1994) due to vegetation, topography (e.g. caves, rocky overhangs) or 'grouped animals' which can make it difficult to count individual animals.

In comparison to other methods that have been used to monitor pinnipeds, such as BoG surveys (Goldsworthy *et al.*, 2021), aerial surveys using fixed-wing aircraft (Christman *et al.*, 2022) or RPAs (Hodgson *et al.*, 2020), or analysis of satellite imagery (Fischbach and Douglas, 2021), camera monitoring provides the largest amount of data at a particular colony per unit of cost. This is because, in the absence of outages, the method provides full coverage of the temporal sampling frame. With the increasing use of deep-learning techniques to automate the manual reading of imagery (Malde *et al.*, 2020), the application of camera monitoring may extend further. In the interim, it is important to note that the collection of permanent records provides greater opportunity but also increases storage and processing overheads for the 'big data' that can be generated by electronic monitoring means. As a result, the manual cost of interpreting imagery often outweighs the initial purchase and deployment of cameras (Hartill *et al.*, 2019).

Consideration also needs to be given to the type of data that can be collected from cameras and how this relates to other historical information. For example, in this study, it was not feasible to routinely identify pups to the same classification used in BoG surveys (refer to Methods). This has implications for interpreting trends through time for those few WA sites for which sufficient BoG surveys have been conducted (refer to Goldsworthy *et al.*, 2021).

To determine whether the capture of vertical footage from an RPA would provide a more accurate way to identify ASLs, several drone trials were conducted in January 2022, at Daw and New Year Islands, at the very eastern end of the remote Recherche Archipelago,

off Israelite Bay (Figure 42). These flights were achieved by modifying on-going research off the south coast of WA. In comparison to the camera images, the resolution of the images obtained when flying at an altitude of 40 – 50 m appear to provide a better means of accurately identifying ASLs to the various age classes. Animals appeared to be unaffected by the presence of the small drone (<2kg category, Mavic 2 Pro). However, the tendency for ASLs to occupy vegetated areas also presents a challenge when performing counts from footage obtained from an RPA. The logistical and fiscal constraints of operating RPA surveys at such remote offshore locations also mean that future sampling opportunities are likely to be determined by the availability of trained crew, vessel time, and weather conditions, rather than a structured approach for obtaining abundance estimates at multiple ASL colonies.

In summary, there is a trade-off in the benefits and limitations in using any method. Obtaining on-going BoG counts for all ASL colonies in WA is not a realistic prospect. Therefore, the use of remote cameras remains a valid means of obtaining in-depth data on ASLs at several indicator sites. The use of cameras at these locations could also guide alternative monitoring methods to be applied at other locations where camera installation is not feasible. Such an approach could provide a better understanding of how ASL counts obtained from the various methods relate to one another, for example, by comparing simultaneous counts from the various methods on the same day.

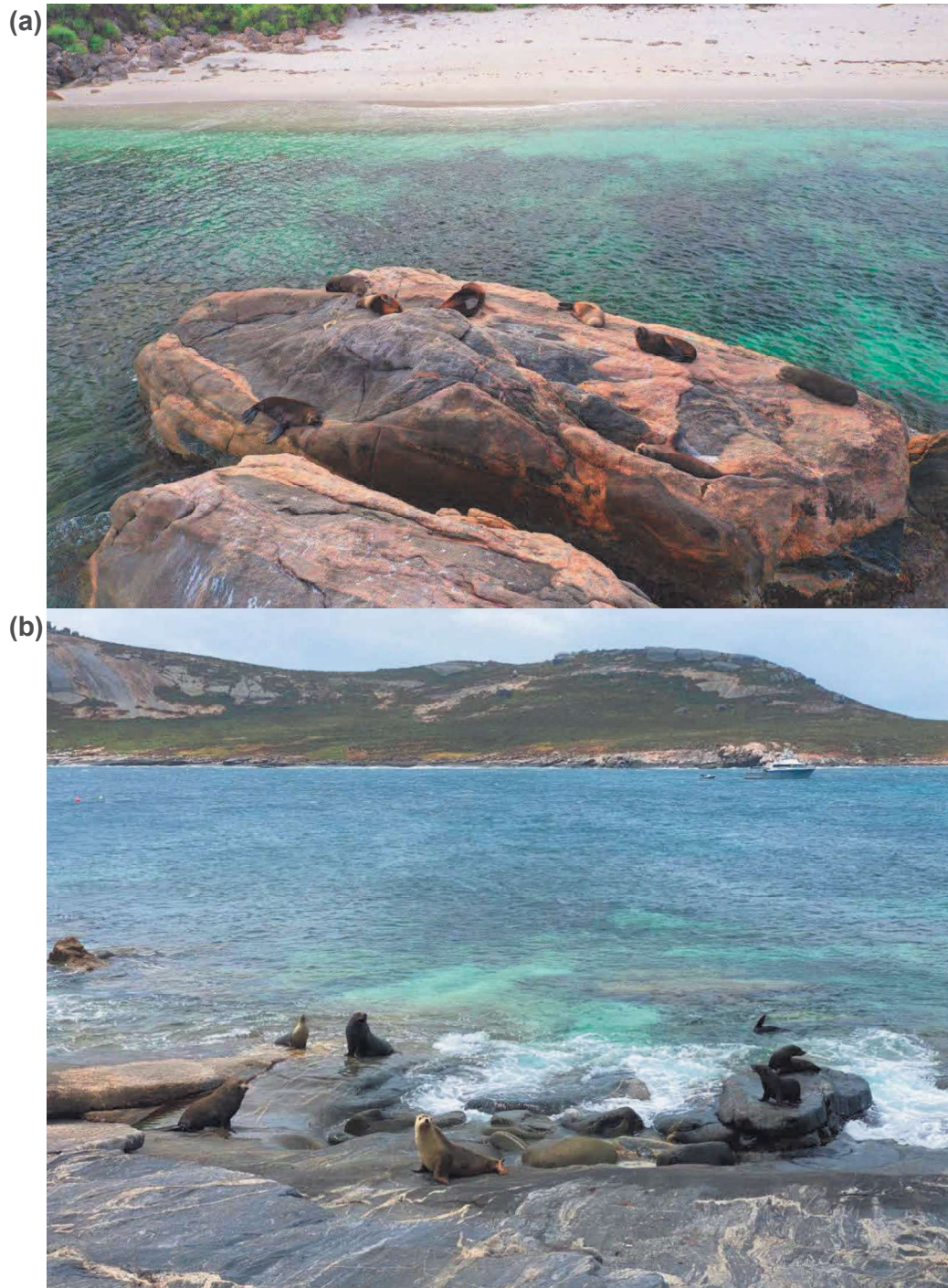

Figure 42. Remote Piloted Aircraft images taken in the Recherche Archipelago in January 2022 where ASLs and LNFS are both visible: (a) on the rock taken off Daw Island and (b) on New Year Island, adjacent to Daw Island. Vessel visible in the background is used as a platform for RPA operations.

5.2 Objective 2. Collect sea lion abundance estimates from study colonies over an 18-month period (full breeding cycle) to update understanding of their conservation status.

Determining the abundance of protected species is challenging as the data necessary for quantitative assessments are generally highly uncertain or incomplete (McPherson and Myers, 2009). This is particularly the case for ASLs in WA. The lack of data has hindered the requirement to accurately determine the timing of the breeding/pupping period for subsequent BoG surveys that provide pup counts, enabling cost-effective estimates of abundance to be obtained for each colony. Goldsworthy *et al.* (2021) summarised the location, pup abundance and survey history of known ASL breeding sites in SA and WA. The outcomes of their publication put the sampling challenge in perspective. Of the 32 WA sites, the number of admissible surveys extending over a 30-year period ranged between 0 to 13 at each site (Goldsworthy *et al.*, 2021), with a mean of 2.2 surveys per site (~ 1 pup count every 14 years).

The second objective of this study was partially met. On the one hand, this study has provided the most detailed information on the relative abundance at ASLs at Buller Island and Wickham Island over an 18-month period. However, due to technical issues and unfavourable weather conditions, limited information on ASLs was collected at Haul Off Rock. Key lessons learned from this pilot study are discussed below within the context of the monitoring and assessment of ASL abundance.

Interestingly, our case study revealed that newborn pups were visible in the camera footage shortly before BoG surveys confirmed the presence of these animals at the colony. This demonstrates that examination of near real-time footage could assist in determining when to schedule targeted BoG surveys (refer to next section). However, it is acknowledged that the tendency for newborn pups to remain in vegetated areas can lead to sightability bias in the use of camera monitoring. The examination of real-time footage is best suited to those locations where the proximity of nearby research staff makes on-site sampling more feasible. Furthermore, the modelled peak in pup abundance obtained from the time series model would assist in the scheduling of targeted BoG surveys.

The Buller Island data provides the most detailed information to date within a full breeding cycle for what appears to be one of the largest WA colonies in terms of population size (Goldsworthy *et al.*, 2021). The results from this study confirmed the presence of at least 55 pups at this location, which was the highest MaxN value recorded in the video footage. This value is larger than the peak of 44 pups obtained from BoG surveys at this site (Goldsworthy *et al.*, 2021; Figure 39), noting that the counts obtained from these two methods represent different aged animals, i.e. camera analysis included older, moulted pups in the category. The upper value of the 95% prediction range obtained from the sinusoidal model at Buller Island has provided a useful measure of absolute abundance of ASL pups and cows at this site. The FoV from the camera at Buller Island is considered to provide good spatial coverage of the island.

The fact that the cycles for pups (~1.3 years) and cows (~1.1 years) obtained from the time series analysis at Buller Island deviated from the expected 17.5-month cycle is possibly due to the lack of data for some periods due to camera outages. The collection and analysis of camera data for more than one reproductive cycle would likely improve this estimate of the breeding cycle. The utility of a long-term monitoring program at this colony to assess trends in population abundance would be enhanced by a better understanding of biases in the applied survey methods. This is consistent with the conversion factor applied

in BoG surveys whereby counts of pups are scaled up to the population (Goldsworthy and Page, 2007), accounting for the fact that this survey method does not provide direct counts for adult ASLs.

The highest MaxN value reported at Wickham Island in this study was 7 individuals for both pups and cows, respectively. As expected of a low pup producing colony (Pitcher, 2018), the observed abundance in this colony was much lower than that of Buller Island. These MaxN values for Wickham Island are slightly larger than the peak pup count at this colony in 2014 (5 pups; Goldsworthy *et al.*, 2021), noting that this comparison is confounded by the different pup definitions and the limited FoV of the camera. The highest MaxN value reported at Haul Off rock was 3 individuals for pups which is considerably lower than the peak pup count of 29 reported at this site in 1989 (range 22 – 29; Gales *et al.*, 1994; Goldsworthy *et al.*, 2021). Again, these comparisons are confounded by the different ways the BoG and camera surveys operate, noting that unidentified animals were often seen outside the boundary used for camera reading, which could explain this discrepancy. It is possible that system outages in this study coincided with the peak of pup abundance for the breeding season, therefore explaining the lower MaxN observed. Any continued camera monitoring at this site would benefit from ground truthing, to investigate the proportion of the island visible in the FoV, compared to the distributions of ASLs. This would enable camera counts to be scaled up to colony counts.

5.3 Objective 3. Provide continuous time-series vision and ancillary in-situ data for other ecological or behavioural research in dynamics of WA sea lion colonies.

The third objective of this study was to provide continuous time-series vision and ancillary *in-situ* data for the three WA ASL colonies. This objective was met, in the sense that all camera footage is available for further interpretation.

Footage collected at Buller Island was available for staff at DPIRD and DBCA to view live via a website. This built on the system applied to the network of remote cameras installed at ~40 boat ramps in WA whereby the scheduling of compliance patrols benefits from access to near real-time footage at boat ramps across the State (Blight and Smallwood 2015; Steffe *et al.*, 2017). Within the context of monitoring ASLs and other wildlife, this extends the utility of monitoring from “data capture” to “data capture and initiate targeted on-site surveys”.

There are technological and networking issues that complicate the cost and transfer of data from remote locations. In some studies, the use of motion-triggered cameras would reduce the volume of data collected which would reduce the cost of data transfer. However, the presence of ASLs in the FoV throughout much of the breeding cycle in the current study would have led to the triggering of many images in the current study. The limited mobile network coverage in some parts of WA also remains an impediment to data transfer. This makes it more difficult to detect whether each camera remains full functioning without making regular field trips to each site.

Several issues were encountered at Haul Off Rock, including the failure of the 48v PoE injectors that ran the computer (refer to Camera System section) and damage to the antennae inadvertently caused by an ASL bull. Further “weather proofing” of camera infrastructure to withstand the extreme weather and high winds would assist in reducing camera outages, as would making the infrastructure less prone to accidental damage by

ASLs. Unfortunately, in-kind technical support available to maintain the gear at Haul Off Rock at the critical time was not available, due to conflicting priorities. This meant that the above issues could not be rectified in a timely manner. We recommend that maintenance trips and contingency planning for field staff are factored into future plans for camera monitoring to reduce the likelihood of data loss from occurring. A modified camera setup with fewer components should also be considered, in addition to a backup camera system, to reduce the likelihood of data loss.

The appropriate storage of video imagery and archiving of metadata can provide a valuable data source for other ecological or behavioural studies involving wildlife. All footage collected during this study is now available for viewing and will hopefully be of interest to other scientists, managers or stakeholders. Further examination of the footage could also assist in interpreting the potential impacts of other threats on ASLs considered by the Threatened Species Scientific Committee, including human disturbance and competition with other pinnipeds (<http://www.environment.gov.au/biodiversity/threatened/species/pubs/22-conservation-advice-23122020.pdf>). The factors are in addition to cow-pup behaviour and antagonistic displays between bulls. The detailed reporting of the “ins and outs” obtained using the video read technique and the subsequent viewing and analysis of the footage would provide additional data on when ASLs transition from the beach to the ocean and vice versa.

As part of the Standard Operating Procedure developed for the camera reading, all manual readers were trained to look for any signs of marine entanglement or damage to ASLs that could be attributed to fishing gear (e.g., presence of hooks, rope or gillnet). No interactions with fishing gear were observed in the footage. There were no clearly visible signs of entanglement or fishing gear related injuries to any of the individuals cited in the footage, although it is acknowledged that visibility bias may have restricted the ability to draw conclusions from this. The resolution of the imagery and the distance from the camera to the FoV are two factors that could influence the ability to identify any signs of marine entanglement or damage to ASLs.

Other animals encountered in the footage included LNFS, sea birds, raptors and the Cape Barron goose *Cereopsis novaehollandiae grisea*. The smaller population of Cape Barron Goose in WA is described as a sub-species and occupies the Recherche Archipelago. This species is listed as vulnerable (<http://www.environment.gov.au/biodiversity/threatened/species/pubs/25978-conservation-advice.pdf>) and examination of footage from Wickham Island confirmed that this species was commonly encountered at the site. It is hoped that further interrogation of the video footage may provide additional information on these species.

5.4 Conclusion

The study pilot tested the use of remote cameras at three WA ASL colonies. The logistical and technical steps necessary to install and maintain this equipment have been provided in detail to assist other researchers in considering the application of this technique elsewhere. We outlined two camera reading methods that enable estimates of ASL abundance to be obtained from the remote camera data. Day to day variations in the abundance of ASLs were estimated for two of the colonies, with limited data on ASL abundance collected for the third colony. The time series analysis applied to the Buller Island data provides arguably the most detailed information within a single reproductive cycle at a WA colony.

Perhaps the biggest advantage provided by camera monitoring is the ability to provide detailed information at the study sites, with much greater temporal coverage than “snapshot” on-site surveys that are often logistically difficult and costly to operate. The ability to view footage of ASLs live from an office location is also very advantageous for the scheduling of BoG surveys at locations where this on-site survey method remains a practical option. In that regard, the early identification of the presence of newborn or black pups is a real benefit of the camera monitoring.

However, camera monitoring does not overcome all the sampling challenges that have created high uncertainty in the understanding of ASL abundance in WA. Nevertheless, the ongoing maintenance and analysis of data on ASL abundance collected from cameras would provide a realistic prospect of collecting long-term information for hard-to-reach colonies which remain out-of-scope for BoG surveys. Such an approach would require regular maintenance trips and technological modifications. The installation of cameras would also assist in identifying the presence of black pups for subsequent BoG or drone surveys. Installing and maintaining cameras at all known WA colonies would be cost-prohibitive. Instead, under a risk-based approach to monitoring, the analysis presented in this report for Buller Island could be replicated for several south coast colonies. This would benefit from assessing the colonies on the south coast for their vulnerability, accessibility, and topography suitable to come up with a subset of locations where cameras would provide indicative information on breeding cycle and relative pup abundance. Such an approach would require more formal research arrangements being made between the various state agencies responsible for managing wildlife and fisheries (see Implications and Recommendations). Adapting on-going operations to enable opportunistic ASL counts to be conducted via an RPA could also improve understanding of where new colonies may exist. In summary, the diversity and remoteness of ASL colonies in WA means that no single survey method is likely to be appropriate for the monitoring of all colonies.

6.0 Implications and Recommendations

It is recommended that any future monitoring of ASL colonies in WA make full use of the outcomes of this study, and the digital library of camera images generated, to develop a sampling program capable of detecting changes in abundance.

More specific implications and recommendations are provided below.

6.1 Monitoring the abundance of ASLs and the potential impacts of commercial fishing

The principal fisheries-related risk to ASLs in WA has been attributed to the Temperate Demersal Gillnet and Demersal Longline Fisheries (TDGDLF). A network of ASL gillnet exclusion zones were implemented in the waters off the TDGDLF in 2018. Although no interactions have been reported in commercial logbooks since these zones were introduced, a recent ecological risk assessment for the Western Australian Temperate Demersal Elasmobranch Resource identified ASLs as being high risk (Watt *et al.*, 2021). This was attributed to the potential for interaction with commercial gillnets, and a lack of population modelling and fishery-independent data validation.

As the potential bycatch of ASLs in the TDGDLF is associated with mortalities of animals from small colonies (Bilgmann *et al.*, 2021), assessing colony-specific risks through analyses of bycatch monitoring data is problematic. This is due to uncertainties in captured sea lions' colony-of-origin, accuracy of colony size estimates, demographic characteristics, and likelihood of unmonitored captures. As part of 13A conditions on the approved wildlife trade operation for this fishery (Condition 7; <https://www.legislation.gov.au/Details/F2021N00202>), DPIRD are required to develop an independent data collection and validation program in the fishery and the information collected must be able to reliably demonstrate the accuracy of all protected species, including ASLs.

The camera approach outlined in this study could assist in the future direct monitoring of those ASL colonies considered to be the most “at-risk”. This would assist in interpreting the potential impacts of those ASL catches assessed through the independent data collection program on the specific colonies. Such an approach would require further consideration of the costs and logistics of monitoring the colonies, in addition to establishing inter-Departmental monitoring responsibilities.

We recommend that inter-agency discussions explore on-going options for monitoring and assessing the status of ASLs in WA.

6.2 More cost-effective BoG surveys

The ability to view a colony in near real time, and to determine the start of the breeding cycle, can assist agencies such as the Department of Biodiversity, Conservation and Attractions in scheduling BoG surveys to conduct pup counts. Further collaboration with other researchers may enable the future reading of camera data to align the broader pup category used in this study with that used in BoG surveys, creating more data consistency.

6.3 General Behavioural/Ecological Research

The focus of this project was on establishing the relative abundance of ASLs within a single reproductive cycle at three colonies. Without being too prescriptive, we have suggested other potential applications of the data that relate to the ecology and behaviour of ASLs, in addition to other wildlife identified in the camera footage. Future examination of the footage could assist in examining the wildlife fauna at these 'hard to reach' locations.

We recommend that any interested parties examine the camera footage.

6.4 Validating deep learning models that can automate the detection of ASLs from camera footage

Remote cameras are increasingly being applied in fisheries and ecological research. This includes the validation of protected species interactions on-board commercial fishing vessels (AFMA, 2015; van Helmond *et al.*, 2020; Khokher *et al.*, 2022) in addition to studies such as this one which monitor wildlife at colonies (Lynch *et al.*, 2015). The development of deep learning methods to automate the manual reading of images from remote cameras is often cited as an area of future research (Hartill *et al.*, 2019), with the intention of reducing the cost of manually reading the camera data. Ground-truthing for image and video data is required to train these methods to correctly detect the desired animals. The verified video images collected as part of this project are available to assist these deep learning methods in identifying ASLs.

We recommend that any interested agency contact DPIRD to discuss data sharing arrangements and access to the validated count data that accompanies the camera footage.

7.0 Extension and Adoption

The rationale and outcomes of this project have been extended to a variety of stakeholders, including commercial fishing representatives, state and federal government agencies and conservation groups. Specific examples include:

Western Australia commercial fishing representatives

- November 2017: Project proposal discussed with industry representatives at the TDGDLF Annual Management Meeting on 2 November 2017. Both TDGDLF and SCCF industry members expressed support for the proposal;
- September 2019: PowerPoint presentation on the camera project provided at the TDGDLF Annual Management Meeting on 5 September 2019.

State and federal government agencies

- September 2021: PowerPoint presentation on DPIRD camera monitoring (including this ASL project) provided at the Australian Fisheries Management Forum Electronic sub-committee meeting on 8 September 2021.

DPIRD-DBCA workshop on ASL monitoring

- September 2022: Workshop held between scientists and managers at the two agencies to consider the outcomes of this project and the establishment of a partnership approach for future monitoring.

Australian Marine Conservation Society

- September 2022: Virtual presentation held with the Australian Marine Conservation Society to go through the key outcomes of this trial.

Upon completion of the project and the publication of the final report, targeted DPIRD social media will ensure that the project outcomes are made widely accessible to the broader community. The lead authors will present a summary of the project outcomes at scheduled Annual Management Meetings for the relevant fisheries and have already offered to provide a research summary to the Western Australian Fishing Industry Council.

The camera system pilot tested in this study has subsequently been adopted in the project “Australian Sea Lions (ASL) in the Perth Metropolitan area (abundance, movement, habitat use and diet)”, funded by Westport. The installation of a remote camera at Carnac Island will provide detail information on the relative abundance of male ASLs at this metropolitan haul out and will be used to detect individuals fitted with satellite tags and/or individual markings where possible.

8.0 Project materials developed

Discussions with industry members related to this project led to the compilation of a [Marine Protected Species Identification Guide](#) to assist in the accurate identification and reporting of protected species interactions.

At the time of writing, a scientific paper is being prepared outlining the results of this study.

9.0 References

- Adame, K., Pardo, M. A., Salvadeo, C., Beier, E., and Elorriaga-Verplancken, F. R. 2017. Detectability and categorization of California sea lions using an unmanned aerial vehicle. *Marine Mammal Science*, 33: 913–925.
- AFMA. 2015. Australian Sea Lion Management Strategy, Southern and Eastern Scalefish and Shark Fishery. 24 pp.
- Afrifa-Yamoah, E., Taylor, S. M., Mueller, U. E., and Fisher, A. 2019. Multiple imputation modelling with climatic and temporal predictors enables accurate imputation of time-lapse camera missing data in recreational fishing surveys. *ICES Journal of Marine Science*, submitted.
- Afrifa-Yamoah, E., Taylor, S. M., and Mueller, U. 2021. Modelling climatic and temporal influences on boating traffic with relevance to digital camera monitoring of recreational fisheries. *Ocean & Coastal Management*, 215: 105947. Elsevier Ltd. <https://doi.org/10.1016/j.ocecoaman.2021.105947>.
- Ahonen, H., Lowther, A. D., Harcourt, R. G., Goldsworthy, S. D., Charrier, I., and Stow, A. J. 2016. The limits of dispersal: Fine scale spatial genetic structure in Australian sea lions. *Frontiers in Marine Science*, 3: 1–12.
- Ben Software. 2016. Ben Software: security spy. Multi-camera CCTV software for the Mac. <http://www.bensoftware.com/securityspy/>.
- Bilgmann, K., Armansin, N., Ferchaud, A. L., Normandeau, E., Bernatchez, L., Harcourt, R., Ahonen, H., *et al.* 2021. Low effective population size in the genetically bottlenecked Australian sea lion is insufficient to maintain genetic variation. *Animal Conservation*, 24: 847–861. <https://zslpublications.onlinelibrary.wiley.com/doi/epdf/10.1111/acv.12688>.
- Blight, S., and Smallwood, C. 2015. Technical manual for camera surveys of boat- and shore-based recreational fishing in Western Australia. Fisheries Occasional Publication No. 121. Government of Western Australia. Department of Fisheries. 32 pp.
- Braccini, M., and Watt, M. 2021. Temperate Demersal Gillnet and Demersal Longline Fisheries Resource Status Report. *In* Status Reports of the Fisheries and Aquatic Resources of Western Australia 2020/21: The State of the Fisheries, pp. 217–223. Ed. by D. J. Newman, S.J., Wise, B.S., Santoro, K.G. and Gaughan. Department of Primary Industries and Regional Development, Western Australia.
- Burnham, K. P., and Anderson, D. R. 2002. Model Selection and Inference: A Practical Information-Theoretic Approach. Springer-Verlag; New York.
- Campbell, R. A. 2003. Demography and genetic population structure of the Australian sea lion (*Neophoca cinerea*). University of Western Australia.
- Campbell, R. A., Gales, N., Lento, G., and Baker, C. 2008. Islands in the sea: extreme female natal site fidelity in the Australian sea lion, *Neophoca cinerea*. *Biology letters*, 4. <https://doi.org/10.1098/rsbl.2007.0487>.
- Campbell, R., Holley, D., Christianopoulos, D., Caputi, N., & Gales, N. (2008). Mitigation of incidental mortality of Australian sea lions in the west coast rock lobster fishery. *Endangered Species Research*, 5(2-3), 345-358.

- Christman, C. L., London, J. M., Conn, P. B., Hardy, S. K., Brady, G. M., Dahle, S. P., Hou, B. X., *et al.* 2022. Evaluating the use of thermal imagery to count harbor seals in aerial surveys. *Mammalian Biology*. Springer International Publishing. <https://doi.org/10.1007/s42991-021-00191-6>.
- Course, G., Pierre, J. P., and Howell, B. K. 2020. What's in the net? Using camera technology to monitor, and support mitigation of wildlife bycatch in fisheries. 54 pp.
- Department of Sustainability, Environment, Water, People and Communities. 2013. Recovery Plan for the Australian Sea Lion (*Neophoca cinerea*). 45 pp. www.environment.gov.au/coasts/species/seals/index.html.
- Desfosses, C., Taylor, S., Adams, P., and Blight, S. 2019. The feasibility of using remotely piloted aircraft systems (RPAS) for recreational fishing surveys in Western Australia.
- Fischbach, A. S., and Douglas, D. C. 2021. Evaluation of satellite imagery for monitoring pacific walrus at a large coastal haulout. *Remote Sensing*, 13: 1–18.
- Gales, N., Shaughnessy, P., and Dennis, T. 1994. Distribution, abundance and breeding cycle of the Australian sea lion *Neophoca cinerea* (Mammalia: Pinnipedia). *Journal of Zoology*, 234: 353–370.
- Gales, N., and Costa, D. 1997. The Australian sealion: a review of an unusual life history. *In* Marine mammal research in the Southern Hemisphere, Book 1., pp. 78–87. Ed. by M. Hindell and C. Kemper. Surrey Beatty and Sons, Sydney.
- Goldsworthy, S., Shaughnessy, P., Page, B., Lowther, A., and Bradshaw, C. 2008. Developing population monitoring protocols for Australian sea lions: enhancing large and small colony survey methodology. 43 pp.
- Goldsworthy, S. D., and Page, B. 2007. A risk-assessment approach to evaluating the significance of seal bycatch in two Australian fisheries. *Biological Conservation*, 139: 269–285.
- Goldsworthy, S. D., Mackay, A. I., Shaughnessy, P. D., Bailleul, F., and Holman, D. 2015. Maintaining the monitoring of pup production at key Australian sea lion colonies in South Australia (2014/15). Final Report to the Australian Marine Mammal Centre. SARDI Research Report Series No. 871 pp.
- Goldsworthy, S. D., Shaughnessy, P. D., Mackay, A. I., Bailleul, F., Holman, D., Lowther, A. D., Page, B., *et al.* 2021. Assessment of the Status and Trends in Abundance of a Coastal Pinniped, the Australian Sea Lion *Neophoca cinerea*. *Endangered Species Research*, 44: 421–437. Inter-Research Science Center. <http://dx.doi.org/10.3354/esr01118>.
- Hamer, P., Whitten, A., and Giri, K. 2019. Developing tools to inform management risk and improve recreational fishery monitoring for a complex multi-sector, multi-jurisdiction fishery: the 'Western Victorian Snapper Stock'.
- Hartill, B. W., Taylor, S. M., Keller, K., and Weltersbach, M. S. 2019. Digital camera monitoring of recreational fishing effort: applications and challenges. *Fish and Fisheries*.
- Hesp, S. A., Tweedley, J. R., McAuley, R., Tink, C. J., Campbell, R. A., Chuwen, B. M., and Hall, N. G. 2012. Informing risk assessment through estimating interaction rates between Australian sea lions and Western Australia's temperate demersal gillnet fisheries. Fisheries Research and Development Corporation and Murdoch University. 82 pp.

- Hodgson, J. C., Holman, D., Terauds, A., Koh, L. P., and Goldsworthy, S. D. 2020. Rapid condition monitoring of an endangered marine vertebrate using precise, non-invasive morphometrics. *Biological Conservation*, 242: 108402. Elsevier. <https://doi.org/10.1016/j.biocon.2019.108402>.
- Kent, C. P. S., and Crabtree, B. 2008. The effectiveness of an established sanctuary zone for reducing human disturbance to Australian sea lions (*Neophoca cinerea*) at Carnac Island, Western Australia. *Tourism in Marine Environments*, 5: 29–42.
- Khokher, M. R., Little, L. R., Tuck, G. N., Smith, D. V., Qiao, M., Devine, C., O’neill, H., *et al.* 2022. Early lessons in deploying cameras and artificial intelligence technology for fisheries catch monitoring: where machine learning meets commercial fishing. *Canadian Journal of Fisheries and Aquatic Sciences*, 79: 257–266.
- Langlois, T., Goetze, J., Bond, T., Monk, J., Abesamis, R. A., Asher, J., Barrett, N., *et al.* 2020. A field and video annotation guide for baited remote underwater stereo-video surveys of demersal fish assemblages. *Methods in Ecology and Evolution*, 11: 1401–1409.
- Ling, J. 1999. Exploitation of fur seals and sea lions from Australian, new Zealand and adjacent subantarctic islands during the eighteenth, nineteenth and twentieth centuries. *Australian Zoologist*, 31: 323–350.
- Lynch, T. P., Alderman, R., and Hobday, A. J. 2015. A high-resolution panorama camera system for monitoring colony-wide seabird nesting behaviour. *Methods in Ecology and Evolution*, 6: 491–499.
- Lynch, T. P., Foster, S., Devine, C., Hegarty, A., McEnnulty, F., Burton, M., and Lyle, J. M. 2020. Trail camera video systems: Investigating their utility in interpreting patterns of marine, recreational, trailer-boat fishers’ access to an offshore Marine Park in differing weather conditions. *ICES Journal of Marine Science*, 77: 3110–3126.
- Malde, K., Handegard, N. O., Eikvil, L., and Salberg, A. B. 2020. Machine intelligence and the data-driven future of marine science. *ICES Journal of Marine Science*, 77: 1274–1285.
- McIntosh, R. R., Holmberg, R., and Dann, P. 2018. Looking without landing-using Remote Piloted Aircraft to monitor fur seal populations without disturbance. *Frontiers in Marine Science*, 5: 1–13.
- McPherson, J. M., and Myers, R. a. 2009. How to infer population trends in sparse data: examples with opportunistic sighting records for great white sharks. *Diversity and Distributions*, 15: 880–890. <http://doi.wiley.com/10.1111/j.1472-4642.2009.00596.x> (Accessed 30 January 2013).
- Osterrieder, S. K., Kent, C. S., Anderson, C. J. R., Parnum, I. M., and Robinson, R. W. 2015. Whisker Spot Patterns: A Noninvasive Method of Individual Identification of Australian Sea Lions (*Neophoca cinerea*). *Journal of Mammalogy*, 96: 988–997.
- Osterrieder, S. K., Salgado Kent, C., and Robinson, R. W. 2017. Responses of Australian sea lions, *Neophoca cinerea*, to anthropogenic activities in the Perth metropolitan area, Western Australia. *Aquatic Conservation: Marine and Freshwater Ecosystems*, 27: 414–435.
- Pitcher, B. 2018. Australian sea lion monitoring framework: background document. 46 pp.
- Pollock, K. H., Jones, C. M., and Brown, T. L. 1994. Angler survey methods and their application in

- fisheries management. American Fisheries Society, Special Publication 25. 371 pp.
- R Core Team. 2018. R: A language and environment for statistical computing. <https://www.r-project.org/>.
- Seber, G. A. F. 1982. The estimation of animal abundance and related parameters. 654 pp.
- Shaughnessy, P., Gales, N., Dennis, T., and Goldsworthy, S. 1994. Distribution and abundance of New Zealand Fur Seals, *Arctocephalus forsteri*, in South Australia and Western Australia. *Wildlife Research*, 21: 667–695.
- Shaughnessy, P. D., Goldsworthy, S. D., Hamer, D. J., Page, B., and McIntosh, R. R. 2011. Australian sea lions *Neophoca cinerea* at colonies in South Australia: Distribution and abundance, 2004 to 2008. *Endangered Species Research*, 13: 87–98.
- Shaughnessy, P. D., Goldsworthy, S. D., and Mackay, A. I. 2015. The long-nosed fur seal (*Arctocephalus forsteri*) in South Australia in 2013-14: Abundance, status and trends. *Australian Journal of Zoology*, 63: 101–110.
- Taylor, S. M., Blight, S. J., Desfosses, C. J., Steffe, A. S., Ryan, K. L., Denham, A. M., Wise, B. S., *et al.* 2018. Thermographic cameras reveal high levels of crepuscular and nocturnal shore-based recreational fishing effort in an Australian estuary. *ICES Journal of Marine Science: fsy066–fsy066*.
- van Helmond, A. T. M., Mortensen, L. O., Plet-Hansen, K. S., Ulrich, C., Needle, C. L., Oesterwind, D., Kindt-Larsen, L., *et al.* 2020. Electronic monitoring in fisheries: Lessons from global experiences and future opportunities. *Fish and Fisheries*, 21: 162–189.
- Watt, M., Braccini, M., Smith, K., and Hourston, M. 2021. Ecological Risk Assessment for the Temperate Demersal Elasmobranch Resource.

Appendix A: Project staff

The roles of the DPIRD project staff in the project were as follows:

Mat Hourston (Research Scientist)

- Conceptualisation, data curation, methodology, formal analysis, writing – original draft

Daniela Waltrick (Technical Officer)

- Technical assistance, data curation, methodology, writing – review and editing

Stuart Blight (Senior Research Officer)

- Technical assistance, writing – review and editing

Ainslie Denham (Senior Research Scientist)

- Methodology, formal analysis, writing – review and editing

Alex Hesp (Senior Research Scientist)

- Methodology, formal analysis, writing – review and editing

Stephen Taylor (Senior Research Scientist)

- Project management, writing – original draft, coordinating ongoing monitoring options.

Appendix B: Buller Island schedule of camera uptime.

Green = full day recorded, Yellow = partial day recorded, orange = no footage recorded, red = end of service

	1	2	3	4	5	6	7	8	9	10	11	12	13	14	15	16	17	18	19	20	21	22	23	24	25	26	27	28	29	30	31						
2018	Aug						Yellow																														
	Sep																																				
	Oct																							Yellow													
	Nov												Yellow											Yellow													
	Dec																																				
2019	Jan																																				
	Feb																																				
	Mar																																				
	Apr																																				
	May																																				
	Jun																																				
	Jul																																				
	Aug																																				
	Sep																																				
	Oct																																				
	Nov																																				
	Dec																																				
2020	Jan																																				
	Feb																																				
	Mar																																				

Appendix C: Haul Off Rock schedule of camera uptime.

Green = full day recorded, Yellow = partial day recorded, Orange = no footage recorded, Red = end of service, Light green = still images recorded at 20 min intervals, * = still images recorded with low resolution

	1	2	3	4	5	6	7	8	9	10	11	12	13	14	15	16	17	18	19	20	21	22	23	24	25	26	27	28	29	30	31				
2018	Aug																																		
	Sep																																		
	Oct																																		
	Nov																																		
	Dec																																		
	Jan																																		
	Feb																																		
	Mar																																		
	Apr																																		
	May																																		
	Jun																																		
	Jul																																		
	Aug																																		
	Sep																																		
	Oct																																		
	Nov																																		
	Dec																																		
	Jan																																		
2020	Jan																																		

Appendix D: Wickham Island schedule of camera uptime.

Green = full day recorded, Yellow = partial day recorded, orange = no footage recorded, red = end of service

	1	2	3	4	5	6	7	8	9	10	11	12	13	14	15	16	17	18	19	20	21	22	23	24	25	26	27	28	29	30	31		
2018	Aug																																
	Sep																																
	Oct																																
	Nov													Yellow	Green	Green	Green	Green	Green	Green	Green	Green	Green	Green	Green	Green	Green	Green	Green	Green	Green		
	Dec	Green	Orange	Orange	Orange	Orange	Orange	Orange	Orange	Orange	Orange	Orange	Orange	Orange	Orange	Orange	Orange	Orange	Orange	Orange	Orange	Orange	Orange	Orange	Orange	Orange	Orange	Orange	Orange	Orange	Orange	Orange	
2019	Jan	Orange	Orange	Orange	Orange	Orange	Orange	Orange	Orange	Orange	Orange	Orange	Orange	Orange	Orange	Orange	Orange	Orange	Orange	Orange	Orange	Orange	Orange	Orange	Orange	Orange	Orange	Orange	Orange	Orange	Orange	Orange	
	Feb	Orange	Orange	Orange	Orange	Orange	Orange	Orange	Orange	Orange	Orange	Orange	Orange	Orange	Orange	Orange	Orange	Orange	Orange	Orange	Orange	Orange	Orange	Orange	Orange	Orange	Orange	Orange	Orange	Orange	Orange	Orange	
	Mar	Orange	Orange	Orange	Orange	Orange	Orange	Orange	Orange	Orange	Orange	Orange	Orange	Orange	Orange	Orange	Orange	Orange	Orange	Orange	Orange	Orange	Orange	Orange	Orange	Orange	Orange	Orange	Orange	Orange	Orange	Orange	
	Apr	Green	Green	Green	Green	Green	Green	Green	Green	Green	Green	Green	Green	Green	Green	Green	Green	Green	Green	Green	Green	Green	Green	Green	Green	Green	Green	Green	Green	Green	Green	Green	
	May	Green	Green	Green	Green	Green	Green	Green	Green	Green	Green	Green	Green	Green	Green	Green	Green	Green	Green	Green	Green	Green	Green	Green	Green	Green	Green	Green	Green	Green	Green	Green	
	Jun	Green	Green	Green	Green	Green	Green	Green	Green	Green	Green	Green	Green	Green	Green	Green	Green	Green	Green	Green	Green	Green	Green	Green	Green	Green	Green	Green	Green	Green	Green	Green	
	Jul	Green	Green	Green	Green	Green	Green	Green	Green	Green	Green	Green	Green	Green	Green	Green	Green	Green	Green	Green	Green	Green	Green	Green	Green	Green	Green	Green	Green	Green	Green	Green	
	Aug	Green	Green	Green	Green	Green	Green	Green	Green	Green	Green	Green	Green	Green	Green	Green	Green	Green	Green	Green	Green	Green	Green	Green	Green	Green	Green	Green	Green	Green	Green	Green	
	Sep	Green	Green	Green	Green	Green	Green	Green	Green	Green	Green	Green	Green	Green	Green	Green	Green	Green	Green	Green	Green	Green	Green	Green	Green	Green	Green	Green	Green	Green	Green	Green	
	Oct	Orange	Orange	Orange	Orange	Orange	Orange	Orange	Red	Red	Red	Red	Red	Red	Red	Red	Red	Red	Red	Red	Red	Red	Red	Red	Red	Red	Red	Red	Red	Red	Red	Red	
	Nov																																
	Dec																																
2020	Jan																																